

**MONARCH™ INDUSTRIAL
FIRE SUPPRESSION
SYSTEM**



by Tyco Fire Suppression & Building Products

TECHNICAL MANUAL

- **VEHICLE PAINT SPRAY BOOTH
PROTECTION MANUAL**

- **OPEN FACE PAINT SPRAY BOOTH
PROTECTION MANUAL**

- **GENERAL PURPOSE:
TOTAL FLOODING/
LOCAL APPLICATION MANUAL**

ULEX 3437 CEx 732

Copyright © 2010 Tyco Fire Suppression & Building Products

Bulletin No. 2016122
UL EX 3830; UL EX 3437

DATE: May 20, 2016
 TO: To Authorized PYRO-CHEM Restaurant System Distributors
 FROM: Product Management, Restaurant Systems
 SUBJECT: NEW Stainless Steel Scissor Linkage and Fusible Link Offering

NOTICE: It is the responsibility of your company to verify that this information has been received by the employees who currently hold valid certification credentials for design and/or service of the system(s) referenced within this bulletin.

We are pleased to announce the New Stainless Steel Scissor Linkage used in the PYRO-CHEM KITCHEN KNIGHT II Restaurant Fire Suppression System and the MONARCH Industrial Dry Chemical System. The new scissor linkage will provide a means for easier installation of the detection line while using a continuous run of wire rope.

The new stainless steel scissor linkage offers the following limitations:

- Maximum Number of Detectors: **20**
- Maximum length of wire rope: **150 ft (45.7 m)**
- Maximum number of Elbows: **40**

New Part No.	Replaces Part No.	Description	Suggested List Price (USD)*
435547	550131/551032	Detector, Series (Scissor Linkage) Each	\$ 35.25
435548	550035/550041	Detector, Series (Scissor Linkage) 25-Pack	\$ 824.00
435546	N/A	Detector, Terminal (Scissor Linkage) Each	\$ 44.00
440495	N/A	Detector, Terminal (Scissor Linkage) 10-Pack	\$ 147.00
439515	N/A	Scissor Linkage 10-Pack	\$ 150.00





*Note: Prices are subject to change without notice. Always refer to the latest price files on the PYRO-CHEM extranet prior to ordering.

Note: The scissor linkage cannot be hooked inside the detector bracket channel when installed.



Copyright © 2016 Tyco Fire Products LP. All rights reserved

The SL style fusible link is also approved to be used with the PYRO-CHEM KITCHEN KNIGHT II and MONARCH fire suppression systems, when installed in the new scissor linkage and detector bracket. The SL fusible links are fully color-coded to help ensure the proper temperature-rated link is installed for the application. Color-coding allows for easy identification by installing technicians and simplifies inspection and validation by local Authorities Having Jurisdiction.

Part No. 439085	Part No. 439086	Part No. 439087	Part No. 439088	Part No. 439089
 <small>009928</small>	 <small>009929</small>	 <small>009930</small>	 <small>009931</small>	 <small>009932</small>
Temperature Rating: 165 °F (74 °C)	Temperature Rating: 212 °F (100 °C)	Temperature Rating: 280 °F (138 °C)	Temperature Rating: 360 °F (183 °C)	Temperature Rating: 450 °F (232 °C)
Maximum Allowable Temperature Exposure: 100 °F (38 °C)	Maximum Allowable Temperature Exposure: 150 °F (66 °C)	Maximum Allowable Temperature Exposure: 225 °F (107 °C)	Maximum Allowable Temperature Exposure: 290 °F (143 °C)	Maximum Allowable Temperature Exposure: 360 °F (182 °C)
Color of Link: Black	Color of Link: White	Color of Link: Blue	Color of Link: Red	Color of Link: Green
Quantity: Pack of 25	Quantity: Pack of 25	Quantity: Pack of 25	Quantity: Pack of 25	Quantity: Pack of 25

This bulletin is a temporary supplement to the KITCHEN KNIGHT II Technical Manual (PN551274-06) dated November 10, 2014 and the MONARCH Technical Manual (PN553565) dated February 1, 2010. The information contained in this bulletin will be added to the manuals upon the next printing.

Should you have questions pertaining to this bulletin, please contact Technical Services as noted below.

**MONARCH™ INDUSTRIAL
FIRE SUPPRESSION
SYSTEM**



by Tyco Fire Suppression & Building Products

VEHICLE PAINT SPRAY BOOTH PROTECTION

TECHNICAL MANUAL

- **COMPONENTS**
- **DESIGN**
- **INSTALLATION**
- **MAINTENANCE**

Copyright © 2010 Tyco Fire Suppression & Building Products

Revised February 1, 2010

TABLE OF CONTENTS

<u>Page</u>	<u>Subject</u>	<u>Revision</u>	<u>Date</u>	<u>Page</u>	<u>Subject</u>	<u>Revision</u>	<u>Date</u>
General Information				Design (Continued)			
1-1	General Information	2	2/1/10	3-2Piping Requirements	3	9/1/06
Components				Nozzle Placement		
2-1	Cylinders & Valve	2	3/17/04	Duct Nozzle Placement		
2-2	Nozzles	4	2/1/10	3-3Duct Nozzle Placement	3	9/1/06
	Cylinder Bracketing			3-4	Nozzle Coverages	3	2/1/10
	MCH3 Control Head			3-4.1	Total Flooding – Exhaust Duct	New	9/1/06
2-3	ECH3 Control Head	2	3/17/04	3-4.2	Notes	New	9/1/06
	NMCH3 Control Head			3-5	Paint Spray Booth Nozzle	3	9/1/06
	MB-P2 Mounting Bracket				Chart – Overhead Application		
	PDA-D2 Adaptor			3-6	Paint Spray Booth Nozzle	2	9/1/06
2-4	Pneumatic Actuating Cylinders	2	3/17/04		Chart – Sidewall Application		
PAC-10			3-7	N-PLU Three-Way Nozzle	3	2/1/10
PAC-200				Application		
2-5	Detection Equipment	2	3/17/04	3-8	Piping Limitations –	3	9/1/06
FLK-1				PCI-15ABC w/1 Nozzle		
FLK-1A			3-9	Piping Limitations –	3	2/1/10
FLH-1				PCI-17ABC w/1 Nozzle		
2-6Fusible Links	4	2/1/10	3-10	Piping Limitations –	3	2/1/10
Thermal Detectors				PCI-17ABC w/2 Nozzles		
	RPS-M Remote Pull Station			3-11	Piping Limitations –	2	9/1/06
2-7	RPS-E2 Electric Pull Station	3	9/1/06		PCI-25sABC w/2 Nozzles		
	Gas Shut-off Valves			3-12	Piping Limitations –	2	9/1/06
Mechanical				PCI-35ABC w/2 Nozzles		
Electrical			3-13	Piping Limitations –	3	2/1/10
2-8	Corner Pulleys	2	3/17/04		PCI-35ABC w/3 Nozzles		
SBP-1			3-14	Piping Limitations –	2	9/1/06
CBP-1				PCI-35ABC w/4 Nozzles		
WBP-1			3-15	Piping Limitations –	2	9/1/06
	Tee Pulley				PCI-70ABC w/3 Nozzles		
	Swing Check Valve			3-16	Piping Limitations –	3	9/1/06
2-9	Electrical Switches	3	9/1/06		PCI-70ABC w/4 Nozzles		
Micro			3-17	Piping Limitations –	1	9/1/06
Alarm Initiating				PCI-70ABC w/4 Nozzles		
	SM-120/24 Solenoid Monitor			3-18	Piping Limitations –	1	9/1/06
2-10	Stainless Steel Actuation Hose	2	3/17/04		PCI-70ABC w/5 Nozzles		
	Pipe and Fittings			3-19	Detector Placement	1	2/1/10
	Pressure Switches			3-20	Notes	New	9/1/06
	Time Delay			Installation			
	Pressure Bleed Down Adaptor			4-1	General	2	3/17/04
2-11	Component List	4	2/1/10		Cylinder Installation		
2-12	Component List (Continued)	2	3/17/04		Control Head Installation –		
Design				Single Cylinder		
3-1	General	3	9/1/06	4-2Multiple Cylinder	2	3/17/04
	Choosing the Proper Agent			4-3Multiple Cylinder PAC-10	2	3/17/04
	Designing the Proper Type of System				or PAC-200		
	Total Flooding			4-4Multiple Cylinder	2	3/17/04
Cylinders				Two Control Heads		
Nozzles			4-5	Fusible Link Detector	2	3/17/04
Temperature Range				Installation		
Piping Requirements			Fusible Links		
					Without Hangers		
				4-6Fusible Links With Hangers	2	3/17/04

- ▶ Indicates revised information
- Indicates no change to text – change in page sequence only

<u>Page</u>	<u>Subject</u>	<u>Revision</u>	<u>Date</u>	<u>Page</u>	<u>Subject</u>	<u>Revision</u>	<u>Date</u>
<u>Installation (Continued)</u>							
4-7	Thermal Detector Installation Setting The Control HeadMCH3/NMCH3 Control HeadECH3 Control Head	2	3/17/04				
4-8	Solenoid Monitor InstallationIn A Detection Circuit	2	3/17/04				
4-9When Used as a Reset Relay Remote Pull Station InstallationRPS-M	2	3/17/04				
4-10RPS-E2 Gas Shut-off Valve InstallationMechanical	3	9/1/06				
4-11Electrical Tee Pulley Installation Micro Switch Installation	3	9/1/06				
4-12	Pipe and Nozzle Installation	3	9/1/06				
4-13	Tee Positioning	2	3/17/04				
4-14	Main/Reserve System Pressure Switch Installation System Checkout After InstallationMechanical Control Head	2	3/17/04				
4-15Electrical Control Head		3/17/04				
4-16	Notes		3/17/04				
<u>Maintenance</u>							
5-1	General Maintenance After DischargeSystem Cleanup After DischargeSystem Cylinder Recharge After Discharge	3	2/1/10				
5-2Piping and NozzlesSystem Reset Regular System Maintenance6 Month MaintenanceAnnual Maintenance6 Year MaintenanceHydrostatic Testing	2	3/17/04				

CHAPTER I

General Information

INTRODUCTION

PYRO-CHEM Vehicle Paint Spray Booth automatic dry chemical fire suppression system is of the pre-engineered type as defined by the NFPA Standard for Dry Chemical Extinguishing Systems, NFPA-17. The extinguishing units described in this manual are intended to be installed, inspected, and maintained in accordance with NFPA-17. Limitations detailed in this manual have been established through extensive testing by Underwriters Laboratories, Inc. Installation and maintenance of the system must conform to the limitations detailed in this manual and be performed by an Authorized PYRO-CHEM dealer.

The PYRO-CHEM Vehicle Paint Booth System utilizes a monoammonium phosphate based dry chemical agent (specifically designed to suppress carbonaceous solid, liquid, gas or electrical fires). The system provides mechanical or electrical automatic actuation and can be manually actuated through a remote mechanical pull station. Upon actuation, the system discharges a pre-determined amount of agent to the hazard area.

The shutdown of fuel and power to the hazard area is required upon system actuation. Exhaust fan(s) in the ventilation system must be shut off prior to system discharge to allow the proper concentration of agent to build up in the hazard area.

The PYRO-CHEM Vehicle Paint Booth System is designed to accommodate a mandatory factory pre-set time delay. This time delay is required based on the UL 1254 compliance testing.

TEMPERATURE LIMITATIONS

The operating temperature range of the PYRO-CHEM Vehicle Paint Booth System is 32 °F (0 °C) minimum to 120 °F (49 °C) maximum.

UL LISTING

The PYRO-CHEM Vehicle Paint Booth Industrial Fire Suppression System has been tested to the UL Standard for Pre-Engineered Dry Chemical Extinguishing System Units, UL1254 (Revised Sept. 29, 1998), and Listed by Underwriters Laboratories, Inc.

CITY OF NEW YORK APPROVAL

The PYRO-CHEM Vehicle Paint Spray Booth Fire Suppression System is approved by the City of New York Fire Department per Certificate of Approval No. 5544 under the following conditions:

1. Prior to installation, plans must be filed with and accepted by New York City Department of Buildings. Additionally, a copy of New York City Department of Buildings docketed plans shall be transmitted to the Fire Department for review and approval.
2. The system shall be installed, periodically inspected, tested and otherwise maintained in accordance with Sections 901, 904.1.1 and 904.4 of New York City Fire Code, NFPA 17 and all applicable New York City Construction Code/Fire Code. Electrical wiring shall be in accordance with the New York City Electrical Code.
3. At least once a month, an inspection shall be conducted by a trained and knowledgeable person to assess that the system is in good working order.
4. The installation, maintenance procedures, and limitations stated in this manual must be complied with.

CHAPTER II COMPONENTS

CYLINDERS & VALVE

PYRO-CHEM Vehicle Paint Spray Booth automatic dry chemical systems are supplied in 15 pound, 17 pound, 25 pound, 35 pound, and 70 pound capacity cylinders. They are the Models PCI-15ABC, PCI-17ABC, PCI-25sABC, PCI-35ABC, and PCI-70ABC. Each cylinder must be separately piped to its own nozzles. All models are charged with dry nitrogen to 350 psi @ 70° F. **These systems are for indoor hazard protection only.**

The valve shown in Figure 2-2 is a pressure sealed, poppet type valve. It is on all cylinders and also the PAC-10 and the PAC-200 cylinders. The valve discharge port is 3/4 in. NPT.

All are rated to protect "A," "B," and "C" Class Hazards.

The dimensions of the cylinders and valve assemblies are shown in **Figure 2-1**. The cylinder is manufactured, tested, and marked in accordance with **DOT** specification 4BW350.

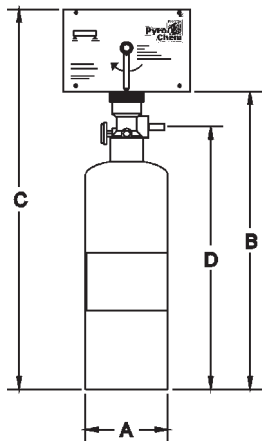

MODEL NO.	A	B	C	D	WEIGHT	MOUNTING BRACKET USED
PCI-15ABC	6.00	21.44	27.19	18.69	30 lb	MB-15
PCI-17ABC	8.00	24.81	30.56	22.06	50 lb	MB-15
PCI-25sABC	8.00	24.81	30.56	22.06	58 lb	MB-15
PCI-35ABC	10.00	29.94	35.69	27.18	71 lb	MB-1
PCI-70ABC	12.00	35.31	41.06	32.56	130 lb	MB-1
ALL DIMENSIONS IN INCHES						

Figure 2-1 Cylinder and Valve Assemblies

002841PC

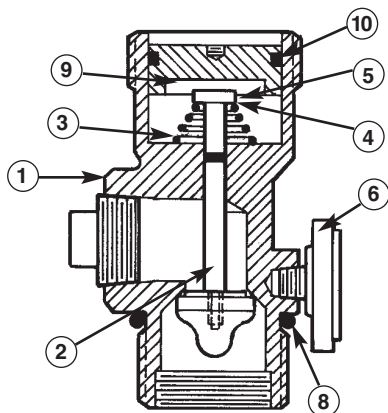

ITEM	PART NO.	DESCRIPTION
1	---	VALVE BODY
2	---	VALVE STEM & CAP ASSEMBLY
3	550022	CONICAL SPRING
4	550261	RETAINING WASHER
5	550024	E-RING
6	550025	PRESSURE GAUGE
7	550026	HIGH TEMPERATURE RELIEF PLUG
8	550029	VALVE BODY O-RING
9	550805	PISTON
10	550636	PISTON O-RING

Figure 2-2 Valve Cross Section

002842PC

NOZZLES

Nozzles have been developed for Vehicle Paint Spray Booth protection. Each nozzle has been designed for use in certain areas of the booth. The Model NV-WA nozzle is used for overhead application in the booth work area or plenum/pit. The Model NV-SW nozzle is used for sidewall application in the booth work area or plenum/pit. An arrow stamped on the nozzle bottom indicates the discharge direction. The Model NV-P1 nozzle is used for overhead application in the backdraft plenum or downdraft pit area. The Model NV-UF nozzle is used for overhead application in the underfloor plenum area. The Model NV-DP2 nozzle is used for horizontal (end position) application in the pit/duct area. The Model NV-DP2 nozzle is also used for end position application for exhaust duct protection. The Model N-PLU nozzle is used as a three-way nozzle for protecting pits, plenums, and under floor trenches. The Model N-DCT nozzle is also an alternate nozzle used for exhaust duct protection. The Model N-DCT nozzle can only be used on 15 lb and 25 lb Cylinders. See **Figure 2-3**.

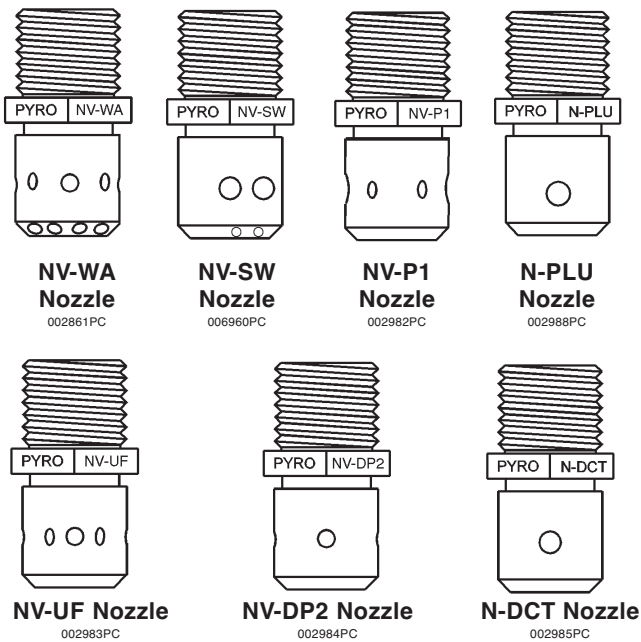

Figure 2-3 Nozzles

CYLINDER BRACKETING

Vertical wall mounting for the **PCI-15ABC**, **PCI-17ABC**, and **PCI-25sABC**, is provided by the Model **MB-15** mounting bracket kit. Vertical wall mounting for the **PCI-35ABC**, and **PCI-70ABC** is provided by the Model **MB-1** mounting bracket kit. See **Figure 2-4**.

For vertical floor mounting of the **PCI-17ABC** and **PCI-25sABC**, an 8 in. channel-type mounting bracket is available, the Model **MB-U8**.

For vertical floor mounting of the **PCI-35ABC**, a 10 in. channel-type mounting bracket is available, the Model **MB-U10**.

For vertical floor mounting of the **PCI-70ABC**, a 12 in. channel-type mounting bracket is available, the Model **MB-U12**.

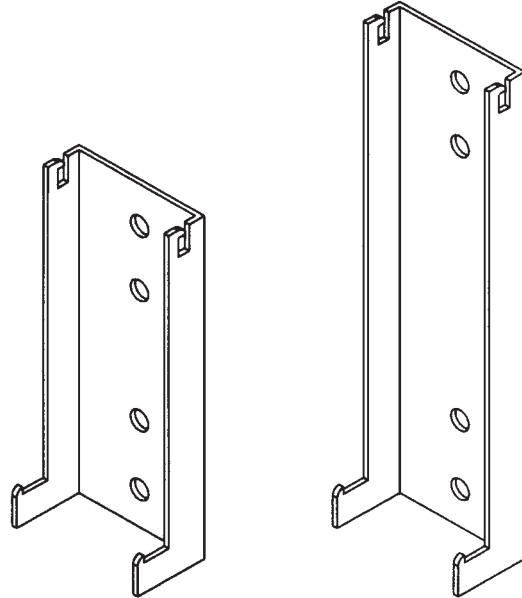

Figure 2-4 Mounting brackets MB-15 and MB-1

002843PC

MODEL MCH3 – MECHANICAL CONTROL HEAD

The Model MCH3 mechanical control head is a fully mechanical control head which can be connected to the PCI-15/17/25s/35/70 cylinder valve. This control head will support a fusible link detection system, a remote mechanical pull station (Model RPS-M), and a mechanical or electric gas shut-off valve. A micro switch (Model MS-SPDT, MS-DPDT, MS-3PDT, or MS-4PDT) can be ordered separately and field installed. It is equipped with a local manual control handle that allows for mechanical system actuation. Operation of the local manual control requires removing the pull pin and rotating the handle clockwise. The Model MCH3 control head can actuate a maximum of five (5) cylinders. See **Figure 2-5**.

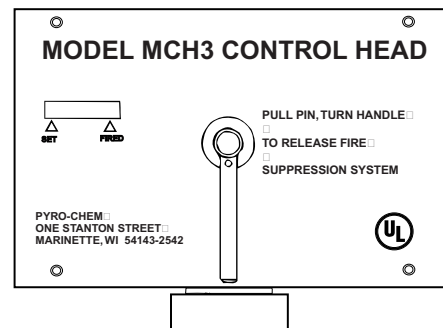

Figure 2-5. Mechanical Control Head.

004790PC

MODEL ECH3 – ELECTRIC CONTROL HEAD

The Model ECH3 electric control head is an electrically operated control head which can be connected to the PCI-15/17/25s/35/70 cylinder valve. This control head will support an electric thermal detection system, a remote mechanical pull station (Model RPS-M), and an electric gas shut-off valve. It will not support a fusible link detection system. A micro switch (Model MS-DPDT) is included. The Model ECH3 control head is available in both 120 VAC (Model ECH3-120) and 24 VDC (Model ECH3-24). It is equipped with a local manual control handle that allows for mechanical system actuation. Operation of the local manual control requires removing the pull pin and rotating the handle clockwise. The Model ECH3 control head can actuate a maximum of five (5) cylinders. See **Figure 2-6**.

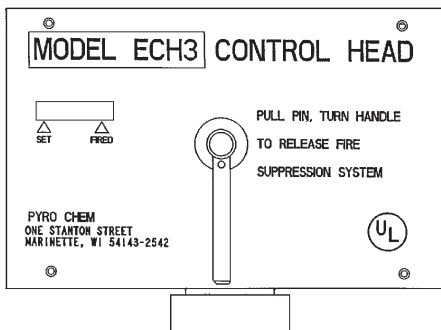

Figure 2-6. Electric Control Head.
 004789PC

MODEL NMCH3 – MECHANICAL CONTROL HEAD

The Model NMCH3 Mechanical Control Head is a fully mechanical control head which can be connected to the PCI-15/17/25s/35/70 a fusible link detection system, a remote mechanical pull station (Model RPS-M), and a mechanical or electric shut-off valve. A micro switch (Model MS-SPDT, MS-DPDT, MS-3PDT, or MS-4PDT) can be ordered separately and field installed. There is no local manual actuation for the Model NMCH3. The Model NMCH3 control head can actuate a maximum of five (5) cylinders. See **Figure 2-6a**.

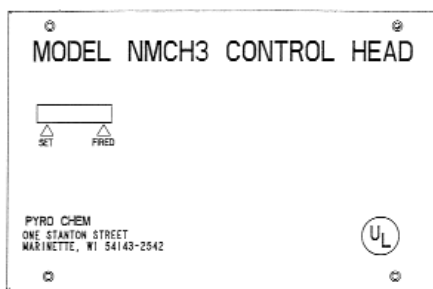

Figure 2-6a. Mechanical Control Head.
 006843PC

MODEL MB-P2 - CONTROL HEAD MOUNTING BRACKET

The Model MB-P2 mounting bracket must be used to mount the Model MCH3, NMCH3 or ECH3 control head if the control head is not mounted directly on a cylinder valve. See **Figure 2-7**.

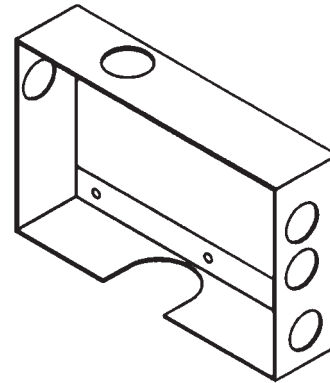

Figure 2-7. Model MB-P2 - Control Head Mounting Bracket.

002846PC

CAUTION

Do not screw the control head directly to a wall as this will warp the control head, not allowing the mechanism to actuate.

MODEL PDA-D2 PNEUMATIC ACTUATING ADAPTOR

The Model PDA-D2 Pneumatic Actuating Adaptor is used to open the cylinder valve when the system is actuated. It must be installed on the valve of each cylinder unless a control head has been mounted on the cylinder valve. See **Figure 2-7a**.

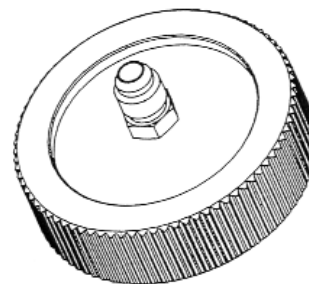

Figure 2-7a. Model PDA-D2 Pneumatic Actuating Adaptor.

006886PC

PNEUMATIC ACTUATING CYLINDERS

1. Model PAC-10.

The Model PAC-10 is a pneumatic actuating cylinder that can actuate a maximum of ten (10) agent cylinders simultaneously. The Model PAC-10 includes a DOT 4BA350 cylinder pressurized with dry nitrogen to 350 PSIG @ 70° F, a brass valve with pressure gauge, and a wall mounting bracket. A Model MCH3, NMCH3 or ECH3 control head must be purchased separately and connected to the PAC-10 to open the valve. See Figure 2-8.

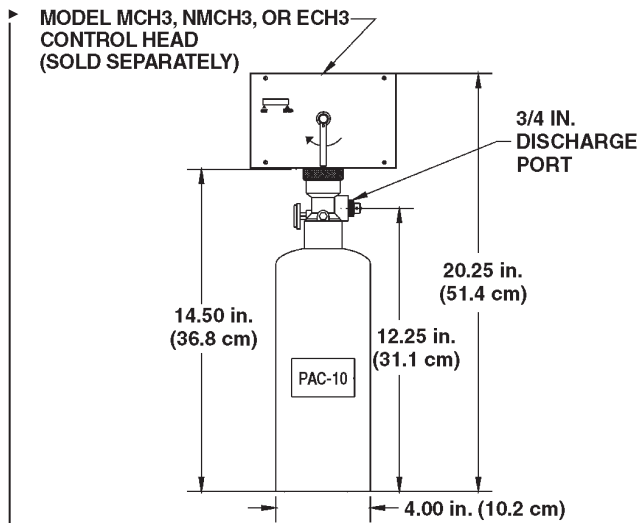

Figure 2-8. Model PAC-10 Pneumatic Actuating Cylinder.

002847PC

2. Model PAC-200.

The Model PAC-200 is a pneumatic actuating cylinder that can actuate a maximum of twenty (20) agent cylinders simultaneously. The Model PAC-200 includes a DOT 4BA350 cylinder pressurized with dry nitrogen to 350 PSIG @ 70° F, a brass valve with pressure gauge, and a wall mounting bracket. A Model MCH3, NMCH3 or ECH3 control head must be purchased separately and connected to the PAC-200 to open the valve. See Figure 2-9.

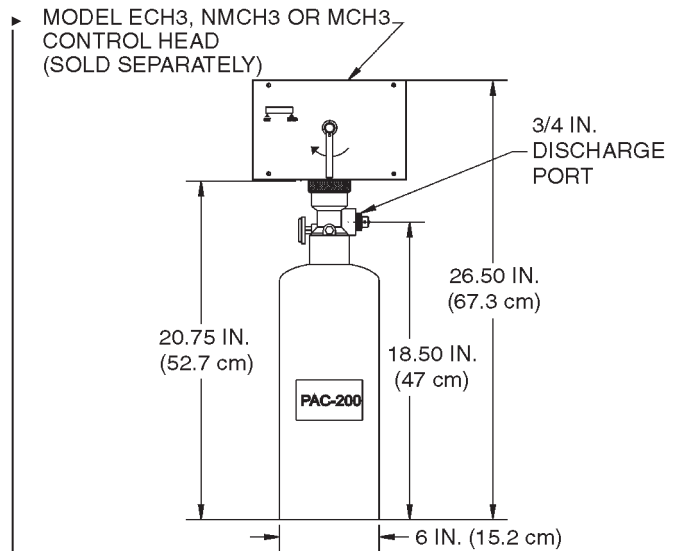

Figure 2-9. Model PAC-200 Pneumatic Actuating Cylinder.

002848PC

DETECTION EQUIPMENT

1. Model FLK-1.

- ▶ The Model FLK-1 fusible link kit includes a 10 in. steel bracket, two (2) 1/2 in. EMT connectors, two (2) cable crimps, and two (2) “S” hooks. Fusible links must be ordered separately. **See Figure 2-10.**

2. Model FLK-1A.

- ▶ The Model FLK-1A fusible link kit includes an 8 in. steel bracket, two (2) 1/2 in. EMT connectors, two (2) cable crimps, and two (2) “S” hooks. Fusible links must be ordered separately.

3. Model FLH-1.

The Model FLH-1 fusible link hanger is an accessory designed to simplify the installation of fusible links in the fusible link line. It can be used with the Model FLK-1/1A fusible link kits (kits must be ordered separately). The Fusible Link Hanger makes it possible to install fusible links without cutting and crimping loops in the fusible link line for each link. They are available in packages of 25 (FLH-25) only. **See Figure 2-11.**

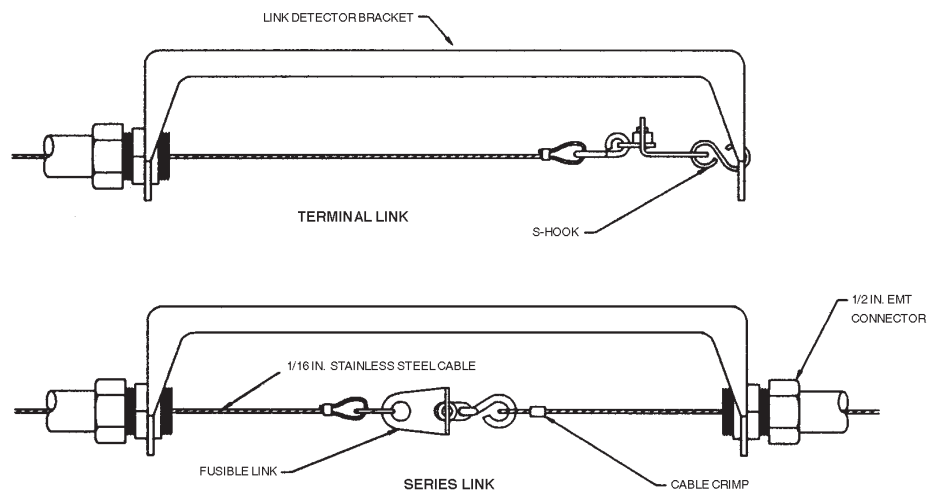

Figure 2-10. Model FLK-1 Fusible Link

002849PC

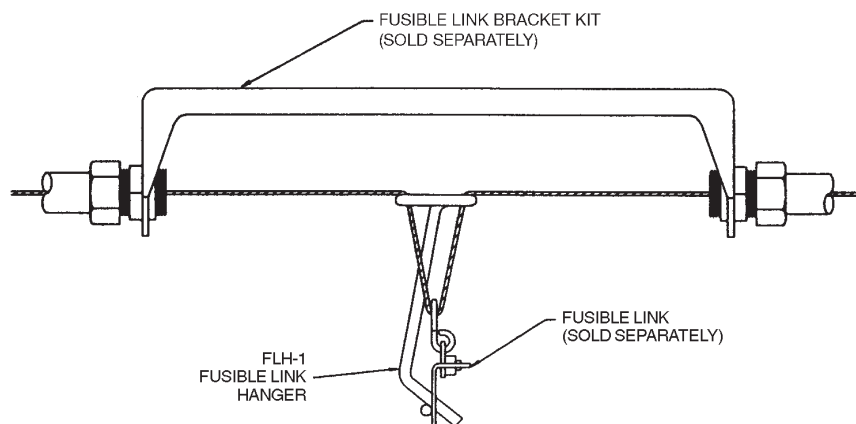

Figure 2-11. Model FLH-1 Fusible Link Hanger

002850PC

4. Fusible Links.

The fusible link is designed to separate at a specific temperature, releasing tension from the fusible link line, causing system actuation. See Figure 2-12.

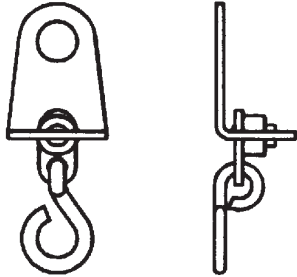

Figure 2-12. ML Style Fusible Link.

002851PC

After determining the maximum ambient temperature at the fusible link location, select the correct fusible link according to the temperature condition chart below:

Fusible Link Model No.	Maximum Ambient Temperature
FL-165	100° F (38° C.)
FL-212	150° F (66° C.)
FL-280	225° F (107° C.)
FL-360	290° F (143° C.)
FL-450	360° F (182° C.)
FL-500	400° F (204° C.)

5. Thermal Detectors.

Rate compensated temperature thermal detectors are normally open, mechanical contact closure switches designed to operate at a factory preset temperature. They are available in six preset temperatures which meet NFPA standards and are UL Listed and FM Approved.

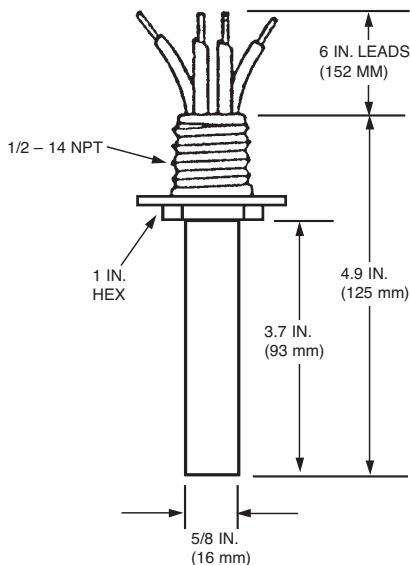

Figure 2-12a. Thermal Detector.

After determining the maximum ambient temperature at the thermal detector location, select the correct thermal detector according to the temperature condition chart below:

Thermal Detector Model No.	Maximum Ambient Temperature
TD-190	150° F (66° C.)
TD-225	185° F (85° C.)
TD-325	285° F (141° C.)
TD-450	410° F (210° C.)
TD-600	560° F (293° C.)

MODEL RPS-M – REMOTE MECHANICAL PULL STATION

Remote manual control for system releasing devices is provided by the Model RPS-M remote mechanical pull station. It is connected to the system releasing device by stainless steel cable. This cable is enclosed in 1/2 in. EMT conduit with corner pulleys at each change in direction. The remote mechanical pull station shall be located at the point of egress from the hazard area. See Figure 2-13.

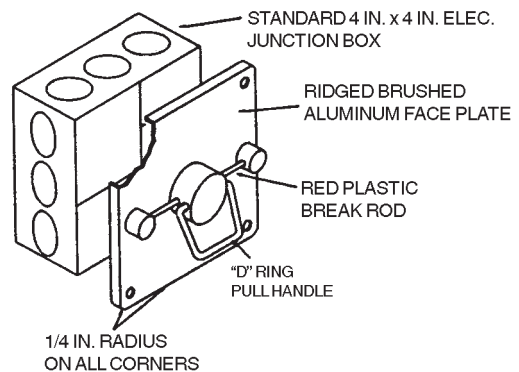
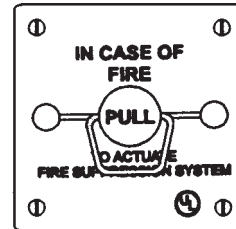
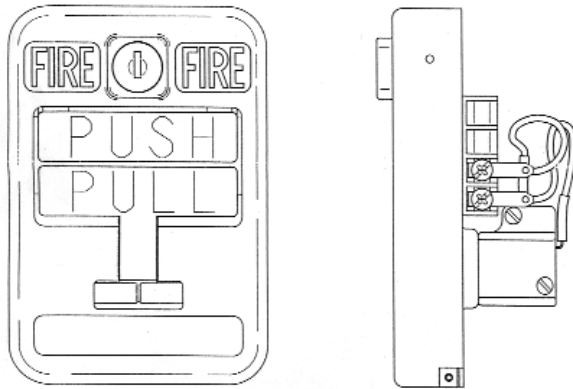

Figure 2-13. Model RPS-M Mechanical Pull Station.

002852PC

MODEL RPS-E2

Remote manual actuation for the Model ECH3 control head is provided by the Model RPS-E2 remote electric pull station. Installation instructions are provided in the installation section of this manual. The remote electric pull station shall be located at the point of egress.



FRONT VIEW SIDE VIEW

Figure 2-13a. Model RPS-E2 Remote Electric Pull Station.

006887PC

GAS SHUT-OFF VALVES

1. Mechanical Gas Shut-off Valve.

A gas shut-off valve is required on all systems used to protect a gas fueled appliance to stop gas flow in the event of system actuation. A mechanical gas valve can be used with either the Model MCH3 or NMCH3 control head. It is connected to the system control head by stainless steel cable. This cable is enclosed in 1/2 in. EMT conduit with a corner pulley at each change in direction. The valves are rated for natural and LP gas (see Figure 2-14). Mechanical gas valves are available in the following sizes:

Model No.	Valve Size	Maximum Operating Pressure	Dim. "A"
GV-75	3/4 in.	5 psi	3/8 in.
GV-100	1 in.	5 psi	3/8 in.
GV-125	1-1/4 in.	5 psi	15/32 in.
GV-150	1-1/2 in.	5 psi	15/32 in.
GV-200	2 in.	5 psi	15/32 in.
GV-250	2-1/2 in.	5 psi	29/32 in.
GV-300	3 in.	5 psi	29/32 in.

*Note: "A" maximum is full open position of valve. Do not exceed. Distortion of internal parts can result.

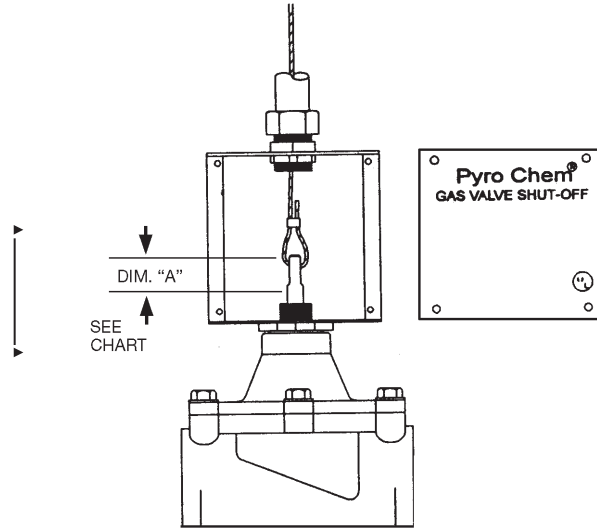

Figure 2-14. GV-Series Mechanical Gas Valve.

002853PC

2. Electric Gas Shut-off Valve.

A gas shut-off valve is required on all systems used to protect a gas fueled appliance to stop gas flow in the event of system actuation. A UL Listed electric gas valve can be used with either the Model MCH3, NMCH3 or ECH3 control head. The valves are rated for natural and LP gas. Valves are available in 120 VAC. Electric gas valves are available in the following sizes:

Model No.	Valve Size	Maximum Operating Pressure
EGVSO-75	3/4 in.	50 psi
EGVSO-100	1 in.	25 psi
EGVSO-125	1-1/4 in.	25 psi
EGVSO-150	1-1/2 in.	25 psi
EGVSO-200	2 in.	25 psi
EGVSO-250	2-1/2 in.	25 psi
EGVSO-300	3 in.	25 psi

Note: A UL Listed manual reset relay is required when using an electric gas valve. The PYRO-CHEM Model SM-120 solenoid monitor may be used for this purpose.

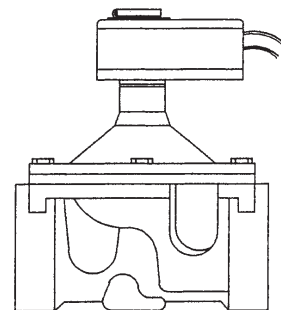

Figure 2-14a. Electric Gas Shut-off Valve.

006844PC

CORNER PULLEYS

1. Model SBP-1.

A corner pulley is used whenever a change in stainless steel cable direction is required. The Model SBP-1 corner pulley is equipped with a set screw fitting for connection to 1/2 in. EMT. See Figure 2-15.

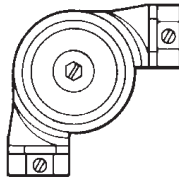

Figure 2-15. Model SBP-1 Corner Pulley.
 000160

2. Model CBP-1.

A corner pulley is used whenever a change in stainless cable direction is required. The Model CBP-1 is a grease-tight corner pulley designed for areas likely to experience excessive deposit build-up. It is equipped with a compression fitting for connection to 1/2 in. EMT. See Figure 2-16.

Note: The Model CBP-1 is not a liquid tight sealing device.

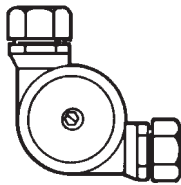

Figure 2-16. Model CBP-1 Corner Pulley.
 000161

3. Model WBP-1.

A corner pulley is used whenever a change in stainless cable direction is required. The Model WBP-1 is a liquid-tight corner pulley designed for areas likely to experience excessive moisture build-up. It is equipped with a female pipe thread for connection to 1/2 in. rigid conduit. See Figure 2-17.

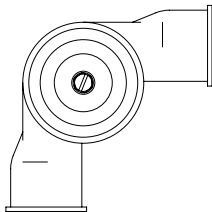

Figure 2-17. Model WBP-1 Corner Pulley.
 006194PC

TEE PULLEY

The Model TP-1 tee pulley is used to connect two mechanical gas valves or two remote mechanical pull stations to a single control head. The tee pulley replaces two standard 90° corner pulleys. See Figure 2-18.

CAUTION

The Tee Pulley must never be used to connect multiple fusible link lines to a single control head.

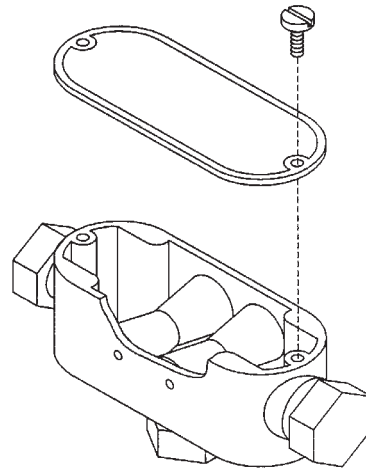

Figure 2-18. Model TP-1 Tee Pulley.
 002857PC

SWING CHECK VALVE

The Swing Check Valve, Part No. 417788, is required when piping a main and reserve Monarch tank on the same distribution piping. It allows the dry chemical agent to discharge through the agent piping leading to the discharge nozzles, while preventing it from flowing into the piping from the other tank. The swing check valve body is constructed of brass with a 1 in. NPT female thread. See Figure 2-19.

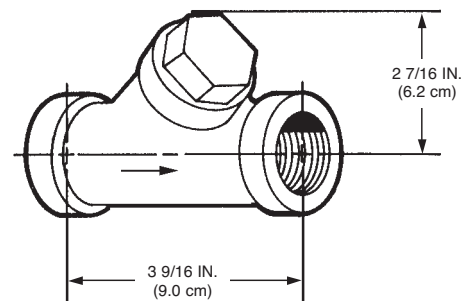

Figure 2-19. Swing Check Valve.
 000430

ELECTRICAL SWITCHES

The electrical switches are intended for use with electric gas valves, alarms, contactors, lights, contractor supplied electric power shut-off devices and other electrical devices that are designed to shut off or turn on when the system is actuated.

Switches are available in kits: One Switch Kit, Part No. 551154; Two Switch Kit, Part No. 551155; Three Switch Kit, Part No. 551156, and Four Switch Kit, Part No. 551157. Mounting hardware and 12 in. wire assemblies are provided with each kit. Each switch has a set of single-pole, double-throw contacts rated:

UL/cUL/CSA Rating
 250 VAC, 21A Resistive
 250 VAC, 2 HP
 125 VAC, 1 HP

ENEC Rating
 IE4T105 μ Approved
 250V, 21A Resistive
 8A Motor Load

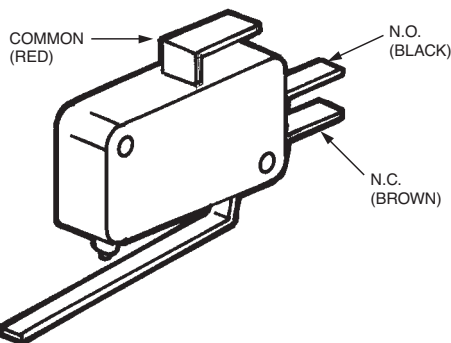

Figure 2-20a. Model MS-SPDT Micro Switch.
 001612

The Alarm Initiating Switch Kit, Part No. 550077, can be field mounted within the control head. This switch must be used to close a supervised alarm circuit to the building main fire alarm panel when the control head actuates. This action will signal the fire alarm panel that there was a system actuation in the hazard area. The switch kit contains all necessary mounting components along with a mounting instruction sheet. The switch is rated 50 mA, 28 VDC.

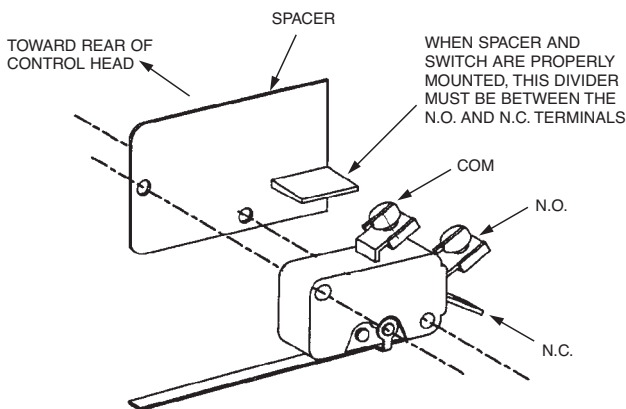

Figure 2-20b. Alarm Initiating Switch.
 004890

See NFPA 72, "National Fire Alarm Code," Initiating Devices section, for the correct method of wiring connection to the fire alarm panel.

MODEL SM-120/24 SOLENOID MONITOR

The Model SM-120/24 solenoid monitor is used in conjunction with the Model ECH3 control head to supervise the actuation and detection circuits. In the event of a problem in the circuit, a light on the monitor goes out. The Model SM-120 is used with the Model ECH3-120 control head. The Model SM-24 is used with the Model ECH3-24 control head. Two sets of NO/NC dry contacts are provided. The unit mounts directly to a three gang wall outlet box. The Model SM-120 acts as a reset relay when used with an electric gas valve. Electric gas valve wiring instructions are provided in the installation section of this manual. See Figure 2-21.

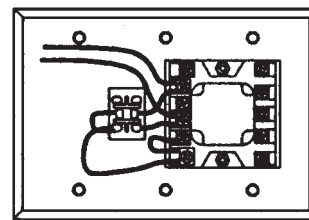
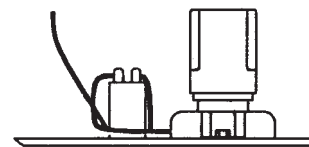
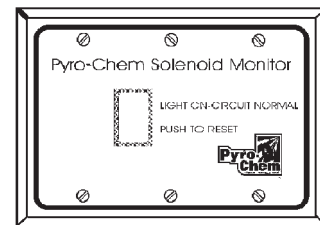

Figure 2-21. Model SM-24/120 Solenoid Monitor.
 002860PC

STAINLESS STEEL ACTUATION HOSE

The Stainless Steel Actuation Hose is used to connect the actuation line compression tees and can also be connected end to end. The hose has the same thread, 7/16-20, as the fittings.

See Figure 2-22.

Hose Part No.	Length
417582	8 in. (20 cm)
31809	16 in. (41 cm)
32336	24 in. (61 cm)
430815	42 in. (107 cm)

Fitting

Part No.	Description
31810	Male Elbow (7/16-20 x 1/4 in. NPT)
31811	Male Tee (7/16-20 x 7/16-20 x 1/4 in. NPT)
32338	Male Straight Connector (7/16-20 x 1/4 in. NPT)



Figure 2-22. Stainless Steel Actuation Hose.

000433

PIPE & FITTINGS

Pipe and fittings must be furnished by the installer. Schedule 40 black, galvanized, chrome plated, or stainless steel pipe must be used. Standard weight malleable, galvanized, chrome plated, or stainless steel fittings must also be used.

PRESSURE SWITCHES

Model PS-SPDT-XP.

The Model PS-SPDT-XP is an explosion proof (NEMA 4; 7; 9) electrical pressure switch which can be field mounted in the discharge piping as shown in Figure 2-23. The switch is UL Listed (CCN: NOWT) and must be installed in accordance with the instructions contained with the switch and this manual. The switch provides one set of NO/NC dry contacts. It is intended for use with electric power shut-off devices (dealer supplied), electric gas valves, alarms, bells, lights, contactors, and other electrical devices designed to shut off or turn on upon system actuation. It is rated for 15 amps @ 125/250 VAC.

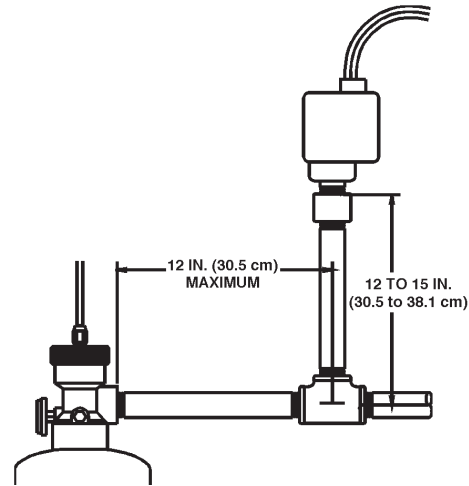

Figure 2-23. Pressure Switch Piping

003025PC

TIME DELAY

The Model TD-10 Time Delay is required to be installed on all Pyro-Chem Vehicle Paint Spray Booth Fire Suppression Systems. The Model T-10 Time Delay is a factory pre-set mechanical time delay which retards the system discharge for a period of 10-20 seconds after actuation to allow for exhaust fan wind-down. The time delay is field mounted between the PYRO-CHEM control head (Models MCH3, NMCH3, ECH3-24, or ECH3-120) and the discharge valve assembly of the agent cylinder(s) and/or pneumatic actuating cylinder(s). See Figure 2-24.

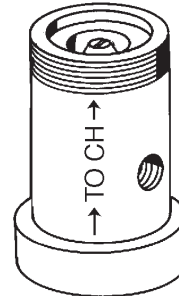

Figure 2-24. Time Delay

003150PC

PRESSURE BLEED DOWN ADAPTOR ASSEMBLY

The Pressure Bleed Down Adaptor Assembly, Part No. 551736, is required to open the valve stem on the tank when bleeding the tank down for six-year maintenance. See Figure 2-25.

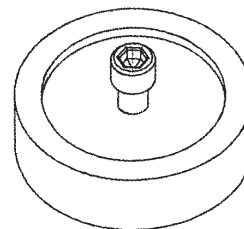

Figure 2-25. Pressure Bleed Down Adaptor Assembly.

004265

COMPONENT LIST
VEHICLE PAINT SPRAY BOOTH SYSTEM

MODEL NO.	DESCRIPTION	PART NO.
PCI-15ABC	15 lb ABC Cylinder and Valve Assembly	550388
PCI-17ABC	17 lb ABC Cylinder and Valve Assembly	551654
PCI-25sABC	25 lb ABC Cylinder and Valve Assembly	550390
PCI-35ABC	35 lb ABC Cylinder and Valve Assembly	551097
PCI-70ABC	70 lb ABC Cylinder and Valve Assembly	551094
PAC-10	Pneumatic Actuating Cylinder	550104
PAC-200	Pneumatic Actuating Cylinder	550690
MB-P2	Control Head Mounting Bracket	550853
MB-15	Mounting Bracket (PCI-15,17,25s Cylinders)	550054
MB-1	Mounting Bracket (PCI-35,70 Cylinders)	550053
▶ MB-U8	8 in. Channel-Type Mounting Bracket	550324
▶ MB-U10	10 in. Channel-Type Mounting Bracket	550383
▶ MB-U12	12 in. Channel-Type Mounting Bracket	550638
MCH3	Mechanical Control Head	551200
NMCH3	Mechanical Control Head	551203
ECH3-24	24VDC Electrical Control Head	551201
ECH3-120	120VDC Electrical Control Head	551202
- - -	8 in. S.S. Actuation Hose	417582
- - -	16 in. S.S. Actuation Hose	31809
- - -	24 in. S.S. Actuation Hose	32336
- - -	42 in. S.S. Actuation Hose	430815
- - -	Male Elbow	31810
- - -	Male Tee	31811
- - -	Male Straight Connector	32338
PDA-D2	Pneumatic Actuating Adaptor	550829
- - -	Swing Check Valve	417788
NV-WA	Nozzle Assembly	551650
NV-SW	Nozzle Assembly	552175
NV-P1	Nozzle Assembly	551652
NV-UF	Nozzle Assembly	551651
NV-DP2	Nozzle Assembly	551653
N-DCT	Nozzle Assembly	551101
N-PLU	Nozzle Assembly	551100
RPS-M	Remote Mechanical Pull Station	551074
RPS-E2	Remote Electric Pull Station	551166
FKL-1	10 in. Fusible Link Bracket	550131
FKL-1A	8 in. Fusible Link Bracket	550132
FLH-25	Fusible Link Hanger (25)	550876
FL-165	165° F Fusible Link	550368
FL-212	212° F Fusible Link	550365
FL-280	280° F Fusible Link	550366
FL-360	360° F Fusible Link	550009
FL-450	450° F Fusible Link	550367
FL-500	500° F Fusible Link	56816
SM-24	24VDC Solenoid Monitor	550303
SM-120	120VAC Solenoid Monitor	550302
TD-190	190° F Thermal Detector	13970
TD-225	225° F Thermal Detector	13976
TD-325	325° F Thermal Detector	13975
TD-450	450° F Thermal Detector	13974
TD-600	600° F Thermal Detector	13971
GV-75	3/4 in. Mechanical Gas Valve	550593
GV-100	1 in. Mechanical Gas Valve	550594
GV-125	1 1/4 in. Mechanical Gas Valve	550595

COMPONENT LIST
VEHICLE PAINT SPRAY BOOTH SYSTEM (Continued)

MODEL NO.	DESCRIPTION	PART NO.
▶ GV-150	1 1/2 in. Mechanical Gas Valve	550596
GV-200	2 in. Mechanical Gas Valve	551049
GV-250	2 1/2 in. Mechanical Gas Valve	550185
GV-300	3 in. Mechanical Gas Valve	550186
EGVSO-75	3/4 in. Electric Gas Valve	550358
EGVSO-100	1 in. Electric Gas Valve	550359
EGVSO-125	1 1/4 in. Electric Gas Valve	550360
EGVSO-150	1 1/2 in. Electric Gas Valve	550361
EGVSO-200	2 in. Electric Gas Valve	550362
EGVSO-250	2 1/2 in. Electric Gas Valve	550363
▶ EGVSO-300	3 in. Electric Gas Valve	550385
MS-SPDT	Micro-Switch – Single Pole Double Throw	551154
MS-DPDT	Micro-Switch – Double Pole Double Throw	551155
MS-3PDT	Micro-Switch – 3 Pole Double Throw	551156
MS-4PDT	Micro-Switch – 4 Pole Double Throw	551157
▶ – – –	Alarm Initiating Switch	550077
PS-SPDT-XP	Pressure Switch – Single Pole Double Throw	550052
CO2-6	6 x CO ₂ Cartridge	551059
CBP-1	Compression Bearing Corner Pulley	423250
SBP-1	Screw Bearing Corner Pulley	415670
▶ WBP-1	Waterproof Corner Pulley (10 Per Package)	550983
TP-1	Tee Pulley	550166
▶ WC-100	Oval Sleeve Crimps (100 Per Package)	550122
▶ – – –	Stop Sleeves (Pack of 10)	24919
– – –	Valve – Piston O-Ring	550636
– – –	Valve – Stem Washer	550284
– – –	Valve – Seat Washer	550021
– – –	Valve – Stem Head	550020
– – –	Valve – Body O-Ring	550029
– – –	Valve – Pressure Gauge	550025
– – –	Valve – Stem	550806
– – –	Valve – Stem O-Ring	550028
– – –	Valve – Conical Spring	550022
– – –	Valve – Piston	550805
TD-10	Time Delay Assembly	551511
▶ – – –	Pressure Bleed Down Adaptor Assembly	551736
– – –	Dry Valve Rebuilding Kit	550037
– – –	Recharge Adaptor	550130
▶ – – –	Dry Valve Hydrotest Adaptor	552182

CHAPTER III SYSTEM DESIGN

General

PYRO-CHEM Industrial Vehicle Paint Spray Booth Fire Suppression System has been designed and tested for use in commercial vehicle paint spray booth applications. The guidelines listed in this chapter deal with the limitations and parameters of various system configurations. It is the responsibility of the Certified installer to ensure that the proper system design is being utilized, and that the system meets the limitations and parameters listed in this chapter. Before attempting to design any system, it is necessary to attend a Factory Certification Training Class and become Certified to install PYRO-CHEM Industrial Vehicle Paint Spray Booth Fire Suppression Systems.

Choosing the Proper Agent

It is necessary for the system designer to consider the combustible material found in the hazard area to ensure proper protection. The agent used in the system must be approved for the hazard class of the combustible material. The following are the hazard classes:

“A” Class – Ordinary solid carbonaceous combustibles. These include wood, paper, cloth, fiberglass, and plastics

“B” Class – Flammable liquids and gases. These include paints, solvents, gasoline, oils, and hydraulic fluids.

“C” Class – Electrical appliances. These include computers, power generators, and power transformers.

“D” Class – Combustible metals such as sodium, potassium, magnesium, titanium, and zirconium. The PYRO-CHEM Industrial Vehicle Paint Spray Booth Fire Suppression System is not intended to protect Class D hazards.

The following guidelines should be used for determining the proper agent:

ABC (monoammonium phosphate-based) – for use with all “A,” “B,” and “C” Class hazards.

As per NFPA 17, pre-engineered dry chemical systems are not approved for deep-seated or burrowing fires (such as ordinary combustibles where the agent cannot reach the point of combustion), or on chemicals that contain their own oxygen supply (such as cellulose nitrate). Do not mix different types of agents, or agents from different manufacturers. Chemical reactions may occur when incompatible chemicals are mixed. **Keep in mind that the agent must be acceptable to the Authority Having Jurisdiction.**

Designing the Proper Type of System

It is necessary for the system designer to consider the physical characteristics and layout of the hazard area to ensure proper protection. The hazard area must meet the criteria for a particular system for that system to be effective. Each nozzle is tested and designed to protect a certain part of the total hazard area.

In order to comply with the approval requirements of UL 1254 Standard, when protecting a Vehicle Paint Spray Booth, **no unclosable openings are allowed.**

The system must also contain a discharge time delay.

The ventilation system must be shut down before the discharge of the system.

Total Flooding

a. Cylinders:

The Models PCI-15ABC, PCI-17ABC, PCI-25sABC, PCI-35ABC, and PCI-70ABC cylinders can be used for total flooding vehicle paint spray booth applications.

b. Nozzles:

- ▶ Seven nozzles are available for use in protecting vehicle paint spray booths:

Nozzle	Application
NV-WA	Work Area/Plenum/Pit (Overhead Position)
NV-SW	Work Area/Plenum/Pit (Sidewall Position)
NV-P1	Backdraft/Pit (Overhead Position)
NV-UF	Under Floor (Overhead Position)
NV-DP2	Pit/Duct (End Position – Horizontal)
N-DCT	Duct Only*
▶ N-PLU	Three-Way Nozzle (Pits, Plenums, Under Floor Trenches)

* Can be used with PCI-15ABC and PCI-25sABC cylinders only

c. Temperature Range:

The operating temperature range for vehicle paint booth applications is 32 °F to 120 °F (0 °C to 48 °C).

d. Piping Requirements:

Piping diagrams include limitations on pipe length and fittings. See the following pages for specific piping design and limitations for each size cylinder.

d. Piping Requirements: (Continued)

Note: All listed piping diagrams represent maximum number of nozzles allowed. In applications that do not require the maximum number of nozzles, the quantity of nozzles can be reduced.

In applications of this type, along with the already listed limitations (notes included with each maximum layout), the following limitations apply:

- On the reduced nozzle side of the piping layout, the largest listed size pipe on the standard configuration layout must be utilized from T1 to nozzle.
- The maximum length of the reduced nozzle side must be the original combination from T1 to T2, and T2 to nozzle. **Note:** In systems utilizing a T3 split, the maximum length of the reduced nozzle side must be the original combination from T1 to T2, T2 to T3, and T3 to nozzle.
- The maximum number of elbows must be the original combination from T1 to T2, and T2 to nozzle. **Note:** In systems utilizing a T3 split, the maximum number of elbows must be the original combination from T1 to T2, T2 to T3, and T3 to nozzle.

e. Nozzle Placement:

The nozzle is to be mounted in the center (See Note) of the protected area, with the discharge holes in the nozzle no greater than six (6) inches from the ceiling. For duct protection, the nozzle is to be mounted in the center. **See Figure 3-1.**

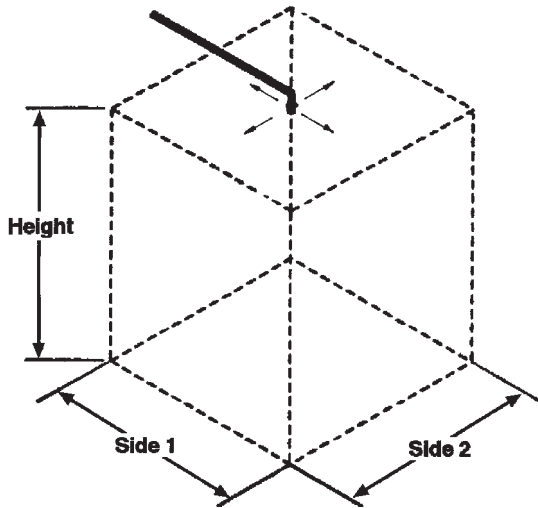

Figure 3-1. Nozzle Location
 002866aPC

For sidewall application, the nozzle is to be mounted no greater than six (6) inches from both the ceiling and wall (see Note) with the arrow pointing towards the center of the protected area. **See Figure 3-2.**

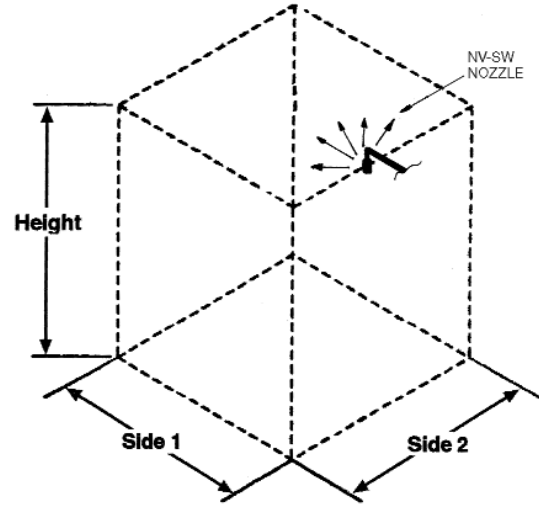

Figure 3-2. Sidewall Nozzle Location
 002866bPC

Note: See Design Chart for allowable offset of nozzles from center of each hazard area.

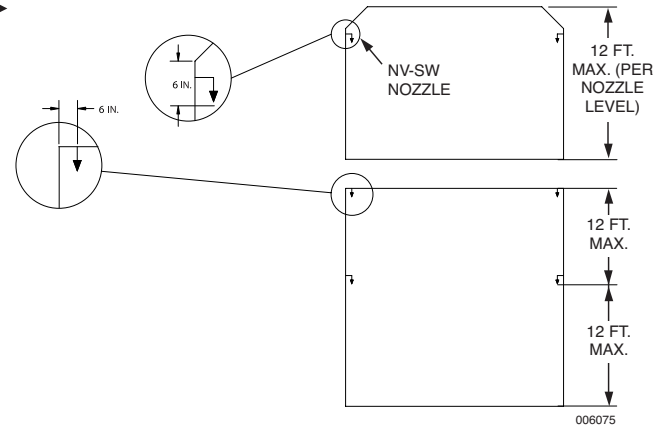

Figure 3-2a.
 006075

f. Duct Nozzle Placement:

1. The maximum duct perimeter is 12 ft (3.7 m). See Figure 3-2b. **Note:** Longest side of a square or rectangular duct cannot exceed 36 in. (91 cm).

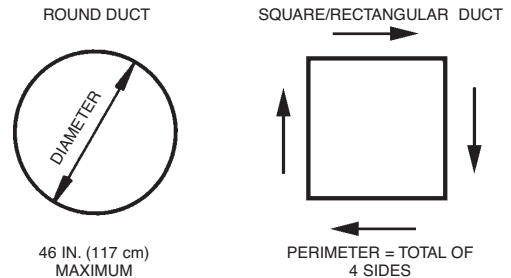

Figure 3-2b.
 003130

f. Duct Nozzle Placement: (Continued)

2. UL 1254 Paragraph 28.2.6 states: “The duct length and elevation shall be the maximum specified by the manufacturer for protection by a single nozzle and shall also have the maximum number of changes in direction (turns) specified by the manufacturer. Longer lengths of duct and greater number of changes in direction are to be protected using additional duct nozzles.”

PYRO-CHEM duct nozzles have not been UL tested to cover any turns in direction in the duct line. The use of 90° and multiple 45° changes that results in a vertical to horizontal change of direction constitutes additional nozzle coverage and dry chemical agent. The nozzle must be centered in the duct and aimed in the direction of the airflow. Protection is also required before and after any obstructions such as fans or dampers in the duct line. If a fan or damper is located at the duct entrance, the nozzle must be placed immediately after the fan or damper, to a maximum of 2 ft (0.6 m) from the duct opening. The entire exhaust ductwork must be protected.

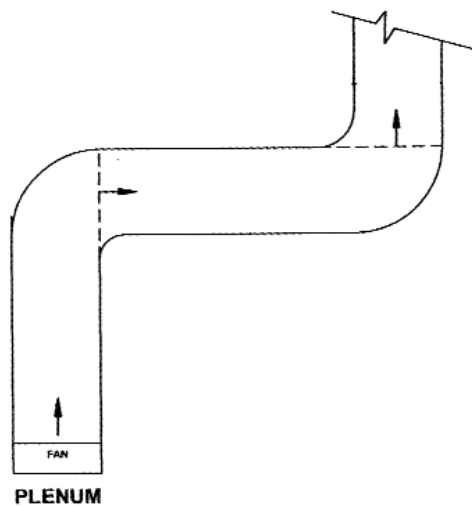

Figure 3-2c.

007490

►g. Nozzle Coverages

Protection	Nozzle	Protection Zone/Nozzle			Specifications Maximum	Nozzle Location within Protection Zone	Nozzle Offset ³	Nozzle Orientation
		L	W	Ht				
Work Area ¹	NV-WA	See Table 3-1			Volume 1920 cu ft Area 160 sq ft Diagonal 18.86 ft	2 ft maximum off center (each side)	0 to 6 in.	Vertical pointing down
Work Area ¹	NV-SW	See Table 3-1A			Volume 1920 cu ft Area 160 sq ft Diagonal 12.8 ft (to farthest corner)	2 ft maximum off center (each side)	0 to 6 in.	Vertical pointing down (orifices in direction of arrow)
Backdraft Plenum	NV-P1	4 ft	14 ft	12 ft	Volume 672 cu ft Area 56 sq ft Side 14 ft	Shortest side-center Longest side-3 inch off center (each side)	0 to 6 in.	Vertical
Pant Leg Plenum ²	NV-P1	4 ft	16 ft	20 ft	Volume 1280 cu ft Area 64 sq ft Side 16 ft	Shortest side-center Longest side-3 inch off center (each side)	0 to 6 in.	Vertical
Pit (Option 1)	NV-P1	24 ft	4 ft	4 ft	Volume 384 cu ft Area 96 sq ft Side 24 ft	Shortest side-center Longest side-center	0 to 6 in.	Vertical
Pit (Option 2)	NV-DP2	24 ft	4 ft	4 ft	Volume 384 cu ft Area 96 sq ft Side 24 ft	Shortest side-center Height-center	2 to 8 in.	Horizontal
Under Floor Plenum	NV-UF	16 ft	14 ft	4 ft	Volume 896 cu ft Area 224 sq ft Side 16 ft	Shortest side-center Longest side-center	0 to 6 in.	Vertical
Exhaust Duct	NV-DP2	3 ft	3 ft	24 ft	Volume 216 cu ft Area 9 sq ft Side 3 ft	Shortest side (cross section) – center Longest side (cross section)	0 to 6 in.	Horizontal for horizontal ducts Vertical for vertical ducts
Exhaust Duct ⁴	N-DCT	12 ft Perimeter or 3 ft 10 in. diameter 24 ft length				Length – center Width – center	0 to 6 in.	Horizontal for horizontal ducts Vertical for vertical ducts

¹ NV-WA and NV-SW nozzles can be used for plenum, pit, or under floor protection. The nozzle maximum specifications must be followed.

² Pant leg dimensions 4 inch minimum x 48 inch maximum.

³ Nozzle offset is the maximum distance from the tip of the nozzle to the closest edge of the protection zone.

⁴ Single nozzle application on a PCI-15ABC or two nozzle application on a PCI-25sABC only.

Note: If the exhaust duct is greater than 46 in. in diameter or 12 ft perimeter, the use of total flood protection can be utilized.

Protection of exhaust ducts larger than 12 ft perimeter or 46 in. in diameter will require the use of total flooding protection for the hazard area, with the following limitation:

- NV-WA or NF-ABC nozzle can be used.
- An NV-WA or NF-ABC must be used at duct bend when the bend turns down from horizontal.
- Horizontal duct runs are protected using a maximum of 18 ft. spacings for NV-WA nozzles and a maximum of 16 ft. spacings for NF-ABC nozzles.
- Vertical duct runs are protected using a maximum of 20 ft spacings for NV-WA or NF-ABC nozzles.
- The ventilation system must be shut down before the start of the system discharge.
- A discharge time delay is required on the MONARCH system.

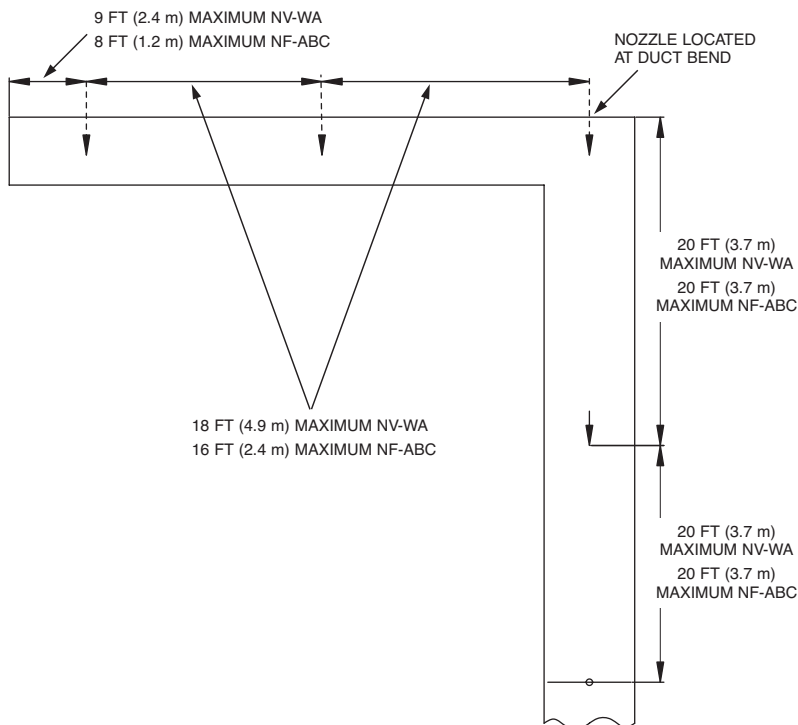
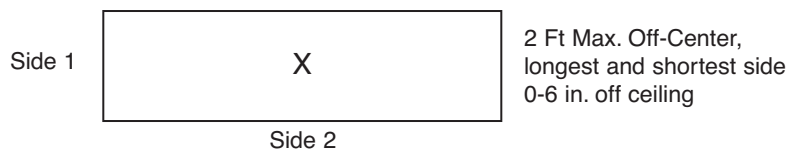

Figure 3-2d.

007506

NOTES:

**TABLE 3-1
Paint Spray Booth Nozzle Protection Chart – Overhead Application**



Maximum Dimensions in feet/nozzle for one (1) Model NV-WA

Side 1 (feet)	Nozzle Height (feet)	Maximum Side 2 (feet)	Side 1 (feet)	Nozzle Height (feet)	Maximum Side 2 (feet)	Side 1 (feet)	Nozzle Height (feet)	Maximum Side 2 (feet)	Side 1 (feet)	Nozzle Height (feet)	Maximum Side 2 (feet)
3	20	18.62	7	20	13.71	11	20	8.73	15	20	6.40
	19	18.62		19	14.44		19	9.19		19	6.74
	18	18.62		18	15.24		18	9.70		18	7.11
	17	18.62		17	16.13		17	10.27		17	7.53
	16	18.62		16	17.14		16	10.91		16	8.00
	15	18.62		15	17.51		15	11.64		15	8.53
	14	18.62		14	17.51		14	12.47		14	9.14
	13	18.62		13	17.51		13	13.43		13	9.85
	12	18.62		12	17.51		12	14.55		12	10.67
	11	18.62		11	17.51		11	14.55		11	10.67
	10	18.62		10	17.51		10	14.55		10	10.67
9	18.62	9	17.51	9	14.55	9	10.67				
8	18.62	8	17.51	8	14.55	8	10.67				
4	20	18.43	8	20	12.00	12	20	8.00	16	20	6.00
	19	18.43		19	12.63		19	8.42		19	6.32
	18	18.43		18	13.33		18	8.89		18	6.67
	17	18.43		17	14.12		17	9.41		17	7.06
	16	18.43		16	15.00		16	10.00		16	7.50
	15	18.43		15	16.00		15	10.67		15	8.00
	14	18.43		14	17.14		14	11.43		14	8.57
	13	18.43		13	17.08		13	12.31		13	9.23
	12	18.43		12	17.08		12	13.33		12	10.00
	11	18.43		11	17.08		11	13.33		11	10.00
	10	18.43		10	17.08		10	13.33		10	10.00
9	18.43	9	17.08	9	13.33	9	10.00				
8	18.43	8	17.08	8	13.33	8	10.00				
5	20	18.18	9	20	10.67	13	20	7.38	17	20	5.65
	19	18.18		19	11.23		19	7.77		19	5.94
	18	18.18		18	11.85		18	8.21		18	6.27
	17	18.18		17	12.55		17	8.69		17	6.64
	16	18.18		16	13.33		16	9.23		16	7.06
	15	18.18		15	14.22		15	9.85		15	7.53
	14	18.18		14	15.24		14	10.55		14	8.07
	13	18.18		13	16.41		13	11.36		13	8.17
	12	18.18		12	16.57		12	12.31		12	8.17
	11	18.18		11	16.57		11	12.31		11	8.17
	10	18.18		10	16.57		10	12.31		10	8.17
9	18.18	9	16.57	9	12.31	9	8.17				
8	18.18	8	16.57	8	12.31	8	8.17				
6	20	16.00	10	20	9.60	14	20	6.86	18	20	5.33
	19	16.84		19	10.11		19	7.22		19	5.63
	18	17.78		18	10.67		18	7.62		18	5.63
	17	17.88		17	11.29		17	8.07		17	5.63
	16	17.88		16	12.00		16	8.57		16	5.63
	15	17.88		15	12.80		15	9.14		15	5.63
	14	17.88		14	13.71		14	9.80		14	5.63
	13	17.88		13	14.77		13	10.55		13	5.63
	12	17.88		12	16.00		12	11.43		12	5.63
	11	17.88		11	16.00		11	11.43		11	5.63
	10	17.88		10	16.00		10	11.43		10	5.63
9	17.88	9	16.00	9	11.43	9	5.63				
8	17.88	8	16.00	8	11.43	8	5.63				

TABLE 3-1A
Paint Spray Booth Nozzle Protection Chart – Sidewall Application

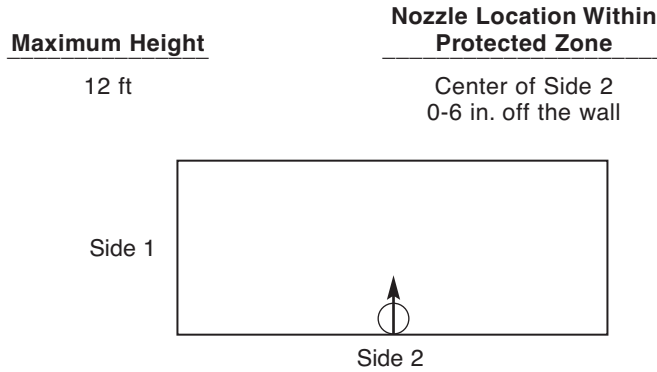

Maximum Dimensions in feet/nozzle for one (1) Model NV-SW

Side 1 Ft	Nozzle Height Ft	Max. Side 2 Ft	Side 1 Ft	Nozzle Height Ft	Max. Side 2 Ft	Side 1 Ft	Nozzle Height Ft	Max. Side 2 Ft
3	12	24.89	7	12	21.43	11	12	13.09
4	12	24.32	8	12	19.98	12	12	8.91
5	12	23.57	9	12	18.20	12.5	12	5.51
6	12	22.61	10	12	15.98			

N-PLU Three-Way Nozzle Application

Protection Area	Nozzle	Protection Zone/Nozzle		
		L	W	H
Down draft Side exhaust Inverted tee	N-PLU	Plenum 24 x 4 x 4 ft (7.3 x 1.2 x 1.2 m) Vertical Riser 6 x 4 x 16 ft (1.8 x 1.2 x 4.9 m)		

Maximum Specifications	Nozzle Location within Protection Zone	Nozzle Orientation
<ul style="list-style-type: none"> ▶ 768 cu ft ▶ (21.8 cu m) 	5 inches up from bottom of plenum. Centered vertically and horizontally in plenum.	Aimed up. Side holes aimed at ends of plenum.

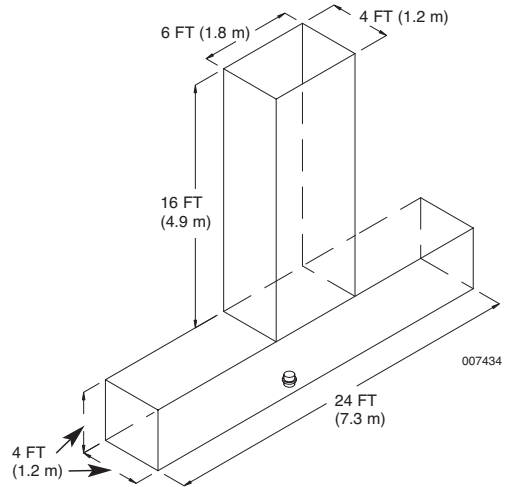

Protection Area	Nozzle	Protection Zone/Nozzle		
		L	W	H
Down draft Pit and Trench Tee shaped	N-PLU	Pit 24 x 8 x 4 ft (7.3 x 2.4 x 1.2 m) Trench 16 x 8 x 4 ft (4.9 x 2.4 x 1.2 m)		

Maximum Specifications	Nozzle Location within Protection Zone	Nozzle Orientation
1280 cu ft (36.2 cu m)	5 inches off wall opposite trench. Centered vertically and horizontally in pit.	Aimed at opposite end of trench. Side holes aimed at opposite ends of pit.

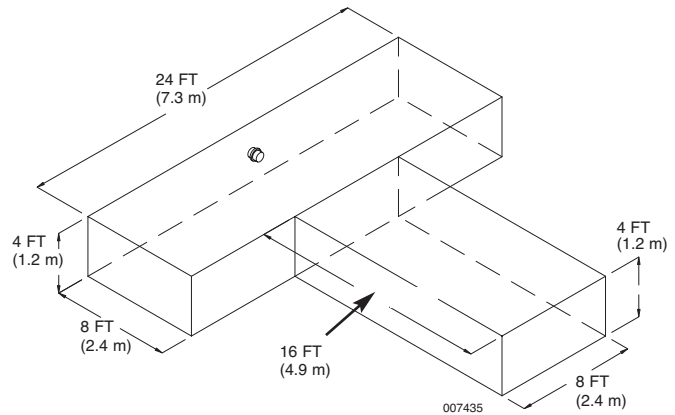

Protection Area	Nozzle	Protection Zone/Nozzle		
		L	W	H
Down draft Pit and Trench L shaped	N-PLU	Pit 24 x 8 x 4 ft (7.3 x 2.4 x 1.2 m) Trench 8 x 8 x 4 ft (2.4 x 2.4 x 1.2 m)		

Maximum Specifications	Nozzle Location within Protection Zone	Nozzle Orientation
1024 cu ft (28.9 cu m)	5 inches off wall opposite longest leg. Centered vertically in pit.	Aimed at opposite end of longest leg. Side holes aimed at opposite end of shortest leg.

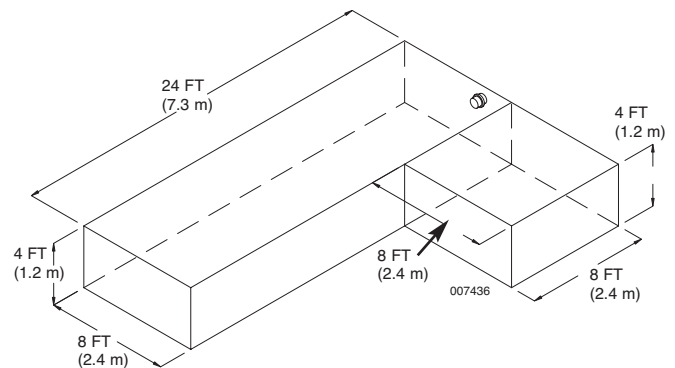

PCI-15ABC with 1 nozzle
 (Duct nozzle only)

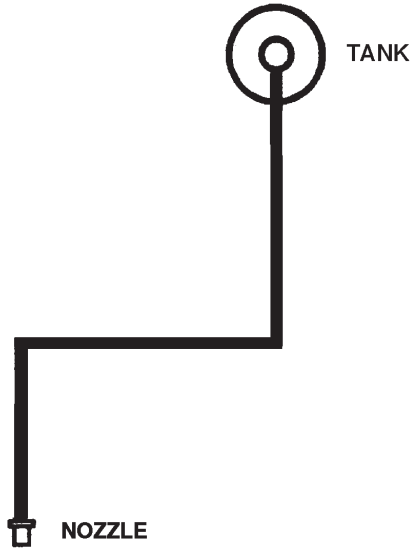

002868PC

Cylinder Size	Nozzle Quantity	Nozzle Type	Piping Section	Size	Length Maximum	Elbows Maximum	Maximum Nozzle Height From Base of Tank
▶ PCI-15ABC	1	N-DCT	Cylinder to Nozzle	3/4 in.	35 ft (10.7 m)	6	16 ft 1 in. (4.9 m)

NOTE:

1. These limitations apply to PCI-15ABC using one N-DCT nozzle.
2. A Main/Reserve Swing Check Valve, Part No. 417788, may be located between the cylinder and the nozzle.
3. All systems protecting vehicle paint spray booths require a factory pre-set time delay.

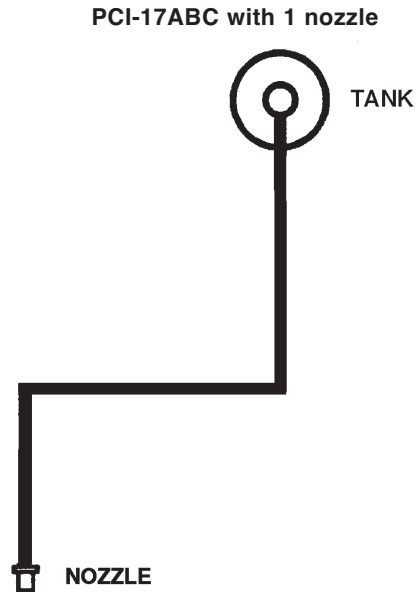

002868PC

Cylinder Size	Nozzle Quantity	Nozzle Type	Piping Section	Size	Length Maximum	Elbows Maximum
PCI-17ABC	1	NV-WA or NV-SW,	Cylinder to Nozzle	3/4 in.	36 ft (10.9 m)	4
▶ PCI-17ABC	1	NV-P1 (See Note 3), NV-DP2, N-PLU, NV-UF	Cylinder to Nozzle	3/4 in.	36 ft (10.9 m)	7

NOTE:

1. A Main/Reserve Swing Check Valve, Part No. 417788, may be located between the cylinder and the nozzle.
2. All systems protecting vehicle paint spray booths require a factory pre-set time delay.
3. When using an NV-P1 nozzle, the two largest discharge orifices in the nozzle body must be positioned parallel to the longest dimension of the hazard being protected.
4. Maximum height of nozzle from base of tank to nozzle – 20 ft (6.1 m).

PCI-17ABC with 2 nozzles

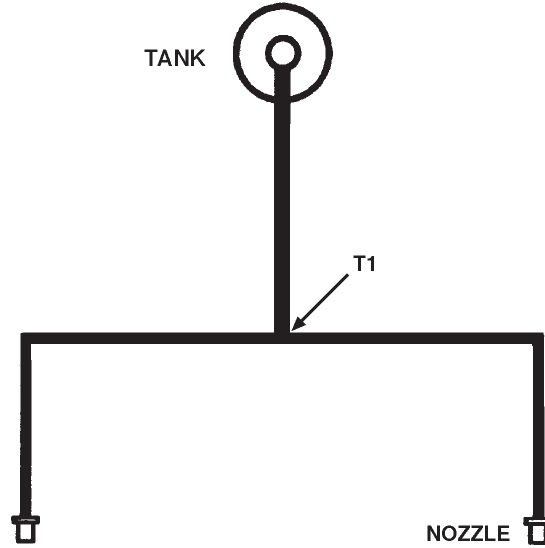

002863PC

Cylinder Size	Maximum Nozzle Quantity	Nozzle Type	Piping Section	Size	Length Maximum	Elbows Maximum
PCI-17ABC	2	NV-UF, or any combination of NV-PI (See Note 5), NV-DP2, N-PLU	Cylinder to T1	3/4 in.	36 ft (10.9 m)	7
			T1 to Nozzle	3/4 in.	14 ft (4.3 m)	4

NOTE:

- ▶ 1. These limitations apply to PCI-17ABC using two nozzles (any combination of either NV-P1, NV-DP2, or N-PLU).
- 2. System piping must be balanced. Balanced piping is that in which the difference between the shortest actual pipe length from T1 to nozzle and the longest actual pipe length from T1 to nozzle does not exceed 10% of the longest actual pipe length from T1 to nozzle. The number and type of fittings for all T1 to nozzle sections must be equal.
- 3. A Main/Reserve Swing Check Valve, Part No. 417788, may be located between the cylinder and T1.
- 4. All systems protecting vehicle paint spray booths require a factory pre-set time delay.
- 5. When using an NV-P1 nozzle, the two largest discharge orifices in the nozzle body must be positioned parallel to the longest dimension of the hazard being protected.
- 6. Maximum height of nozzle from base of tank to nozzle – 20 ft (6.1 m).

PCI-25sABC with 2 Nozzles
 (Duct nozzles only)

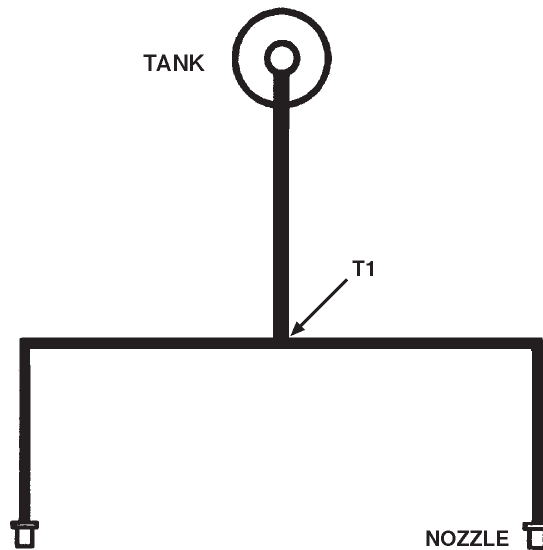

002863PC

Cylinder Size	Maximum Nozzle Quantity	Nozzle Type	Piping Section	Size	Length Maximum	Elbows Maximum	Maximum Nozzle Height From Base of Tank
PCI-25sABC	2	N-DCT	Cylinder to T1	3/4 in.	35 ft (10.7 m)	5	16 ft. 1 in. (4.9 m)
			T1 to Nozzle	3/4 in.	15 ft (4.6 m)	3	

NOTE:

1. These limitations apply to PCI-25sABC using two N-DCT nozzles.
2. System piping must be balanced. Balanced piping is that in which the difference between the shortest actual pipe length from T1 to nozzle and the longest actual pipe length from T1 to nozzle does not exceed 10% of the longest actual pipe length from T1 to nozzle. The number and type of fittings for all T1 to nozzle sections must be equal.
3. A Main/Reserve Swing Check Valve, Part No. 417788, may be located between the cylinder and T1.
4. All systems protecting vehicle paint spray booths require a factory pre-set time delay.

PCI-35ABC with 2 nozzles

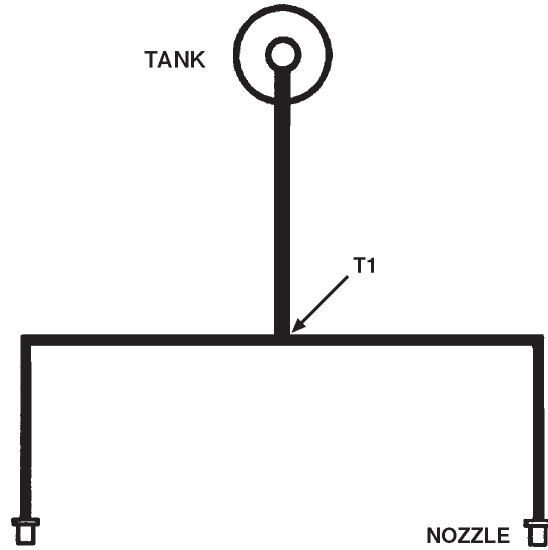

Cylinder Size	Maximum Nozzle Quantity	Nozzle Type	Piping Section	Size	Length Maximum	Elbows Maximum
PCI-35ABC	2	NV-WA or NV-SW	Cylinder to T1	3/4 in.	36 ft (11 m)	4
			T1 to Nozzle	3/4 in.	14 ft (4.3 m)	2

NOTE:

1. These limitations apply to PCI-35ABC using two NV-WA or NV-SW nozzles.
2. System piping must be balanced. Balanced piping is that in which the difference between the shortest actual pipe length from T1 to nozzle and the longest actual pipe length from T1 to nozzle does not exceed 10% of the longest actual pipe length from T1 to nozzle. The number and type of fittings for all T1 to nozzle sections must be equal.
3. A Main/Reserve Swing Check Valve, Part No. 417788, may be located between the cylinder and T1.
4. All systems protecting vehicle paint spray booths require a factory pre-set time delay.
- ▶ 5. Maximum height of nozzle from base of tank to nozzle – 20 ft (6.1 m).

PCI-35ABC with 3 nozzles

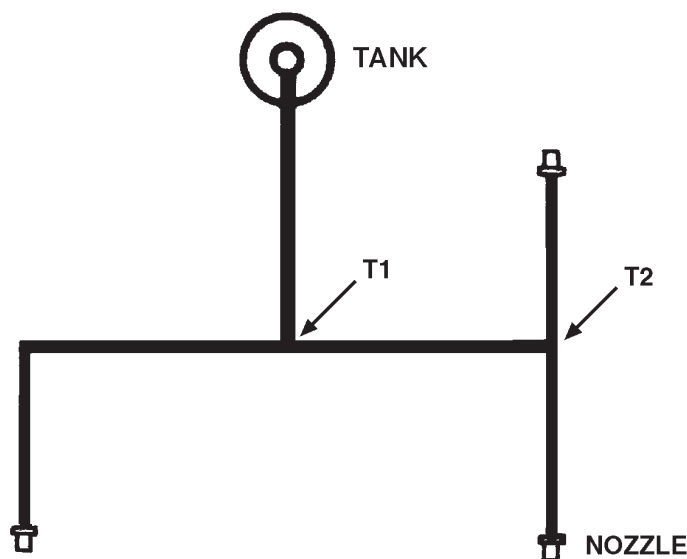

002867PC

Cylinder Size	Maximum Nozzle Quantity	Nozzle Type	Piping Section	Size	Length Maximum	Elbows Maximum
PCI-35ABC (See Note 1)	3	1 – NV-WA or NV-SW and 2 of any combination of: NV-P1 (See Note 5), NV-UF, NV-DP2	Cylinder to T1	3/4 in.	30 ft (9.1 m)	4
			T1 to T2	3/4 in.	12 ft (3.7 m)	2
			T2 to Nozzle	3/4 in.	8 ft (2.4 m)	2
			T1 to Nozzle	3/4 in.	12 ft (3.7 m)	2
PCI-35ABC	3	NV-UF or any combination NV-P1 (See Note 5), NV-DP2, N-PLU	Cylinder to T1	3/4 in.	36 ft (10.9 m)	7
			T1 to T2	3/4 in.	14 ft (4.3 m)	3
			T2 to Nozzle	3/4 in.	8 ft (2.4 m)	2
			T1 to Nozzle	3/4 in.	12 ft (3.7 m)	4

NOTE:

1. These limitations apply to PCI-35ABC using three nozzles (1 NV-WA or NV-SW and 2 of any combination of NV-P1, NV-UF, or NV-DP2).
2. For systems that have been tested with unbalanced piping, the difference in the length of piping must not exceed 10% of the maximum unbalanced ratio tested.
3. A Main/Reserve Swing Check Valve, Part No. 417788, may be located between the cylinder and T1.
4. All systems protecting vehicle paint spray booths require a factory pre-set time delay.
5. When using an NV-P1 nozzle, the two largest discharge orifices in the nozzle body must be positioned parallel to the longest dimension of the hazard being protected.
6. Model NV-WA or NV-SW nozzle must be located on "T1 to nozzle" branch only.
7. Maximum height of nozzle from base of tank to nozzle – 20 ft (6.1 m).

PCI-35ABC with 4 nozzles

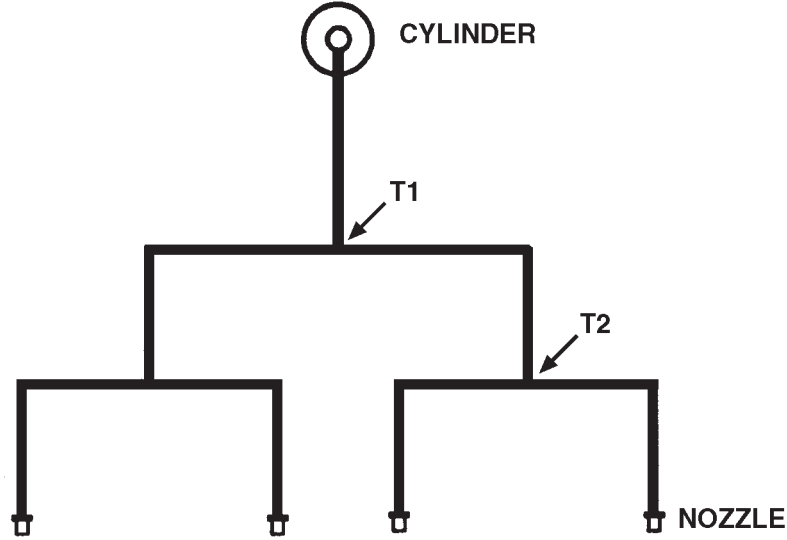

002864PC

Cylinder Size	Maximum Nozzle Quantity	Nozzle Type	Piping Section	Size	Length Maximum	Elbows Maximum
PCI-35ABC	4	Any Combination of NV-P1 (see Note 5), NV-DP2, or NV-UF	Cylinder to T1	1 in.	30 ft (9.1 m)	7
			T1 to T2	1 in.	8 ft (2.4 m)	2
			T2 to Nozzle	3/4 in.	8 ft (2.4 m)	4
PCI-35ABC	4	NV-UF or any combination of NV-P1, NV-DP2, N-PLU	Cylinder to T1	1 in.	30 ft (9.1 m)	7
			T1 to T2	1 in.	8 ft (2.4 m)	2
			T2 to Nozzle	3/4 in.	8 ft (2.4 m)	4

NOTE:

1. System piping must be balanced. Balanced piping is that in which the difference between the shortest actual pipe length from T1 to nozzle and the longest actual pipe length from T1 to nozzle does not exceed 10% of the longest actual pipe length from T1 to nozzle. T2 to nozzle on the same branch must not exceed 10% of each other. The number and type of fittings for all last tee to nozzle sections must be equal.
2. A Main/Reserve Swing Check Valve, Part No. 417788, may be located between the cylinder and T1.
3. All systems protecting vehicle paint spray booths require a factory pre-set time delay.
4. When using an NV-P1 nozzle, the two largest discharge orifices in the nozzle body must be positioned parallel to the longest dimension of the hazard being protected.
5. Maximum height of nozzle from base of tank to nozzle – 20 ft (6.1 m).

PCI-70ABC with 3 nozzles

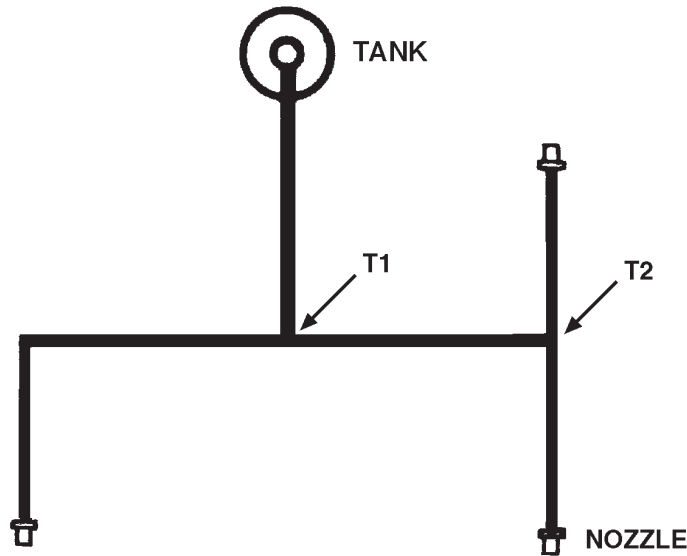

002867PC

Cylinder Size	Maximum Nozzle Quantity	Nozzle Type	Piping Section	Size	Length Maximum	Elbows Maximum
PCI-70ABC	3	NV-WA or NV-SW	Cylinder to T1	1 in.	40 ft (12.2 m)	4
			T1 to T2	3/4 in.	18 ft (5.5 m)	2
			T1 to Nozzle	3/4 in.	18 ft (5.5 m)	2
			T2 to Nozzle	3/4 in.	9 ft (2.7 m)	2

NOTE:

1. These limitations apply to PCI-70ABC using three NV-WA or NV-SW nozzles.
2. For systems that have been tested with unbalanced piping, the difference in the length of piping must not exceed 10% of the maximum unbalanced ratio tested.
3. A Main/Reserve Swing Check Valve, Part No. 417788, may be located between the cylinder and T1.
4. All systems protecting vehicle paint spray booths require a factory pre-set time delay.
5. Maximum height of nozzle from base of tank to nozzle – 20 ft (6.1 m).

PCI-70ABC with 4 nozzles

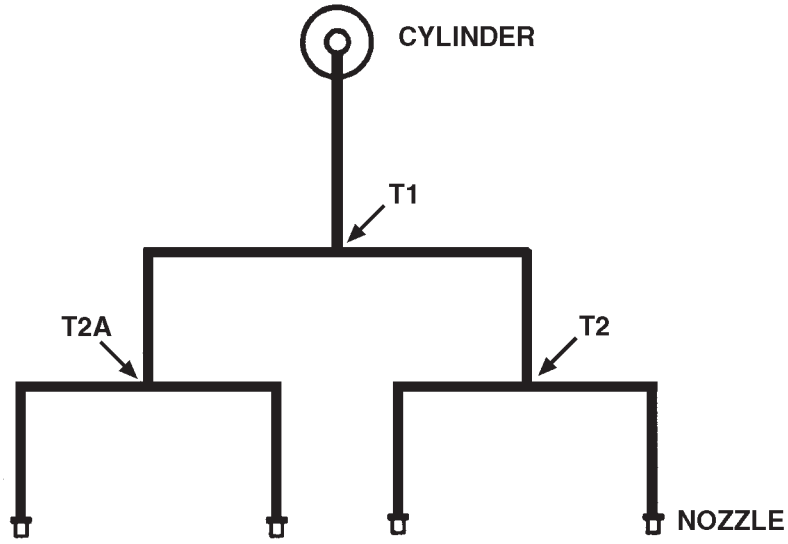

002864PC

Cylinder Size	Maximum Nozzle Quantity	Nozzle Type	Piping Section	Size	Length Maximum	Elbows Maximum
PCI-70ABC	4	NV-WA or NV-SW	Cylinder to T1	1 in.	40 ft (12.2 m)	4
			T1 to T2	1 in.	18 ft (5.5 m)	2
			T2 to Nozzle	3/4 in.	9 ft (2.7 m)	2

Cylinder Size	Maximum Nozzle Quantity	Nozzle Type	Piping Section	Size	Length Maximum	Elbows Maximum
PCI-70ABC	4	3 - NV-WA or NV-SW and 1 of: NV-P1 (See Note 5) NV-UF NV-DP2	Cylinder to T1	1 in.	40 ft (12.2 m)	4
			T1 to T2	1 in.	18 ft (5.5 m)	2
			T2 to Nozzle	3/4 in.	9 ft (2.7 m)	2

(Continued)

PCI-70ABC with 4 nozzles (Continued)

Cylinder Size	Maximum Nozzle Quantity	Nozzle Type	Piping Section	Size	Length Maximum	Elbows Maximum
PCI-70ABC	4	2 – NV-WA or NV-SW and 2 of any combination of NV-P1 or NV-DP2 (See Note 5)	Cylinder to T1	1 in.	40 ft (12.2 m)	4
			T1 to T2	1 in.	18 ft (5.5 m)	2
			T1 to T2A*	1 in.	18 ft (5.5 m)	3
			T2 to Nozzle	3/4 in.	9 ft (2.7 m)	2
			T2A* to Nozzle	3/4 in.	9 ft (2.7 m)	2

* The Models NV-P1 and NV-D/P2 must be located on branch T2A to nozzle only.

NOTE:

1. These limitations apply to PCI-70ABC using four NV-WA or NV-SW nozzles.
2. System piping must be balanced. Balanced piping is that in which the difference between the shortest actual pipe length from T1 to nozzle and the longest actual pipe length from T1 to nozzle does not exceed 10% of the longest actual pipe length from T1 to nozzle. T2 to nozzle on the same branch must not exceed 10% of each other. The number and type of fittings for all last tee to nozzle sections must be equal.
3. A Main/Reserve Swing Check Valve, Part No. 417788, may be located between the cylinder and T1.
4. All systems protecting vehicle paint spray booths require a factory pre-set time delay.
5. When using an NV-P1 nozzle, the two largest discharge orifices in the nozzle body must be positioned parallel to the longest dimension of the hazard being protected.
- ▶ 6. Maximum height of nozzle from base of tank to nozzle – 20 ft (6.1 m).

PCI-70ABC with 5 nozzles

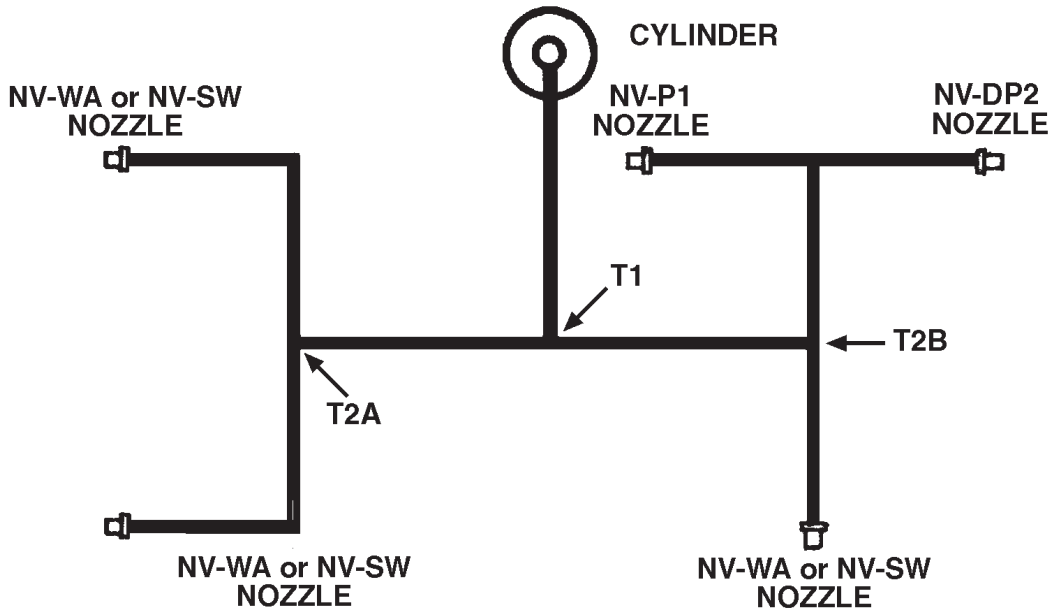

002865PC

Cylinder Size	Maximum Nozzle Quantity	Nozzle Type	Piping Section	Size	Length Maximum	Elbows Maximum
PCI-70ABC	5	3 - NV-WA or NV-SW and 1 - NV-P1 (see Note 6) and 1 - NV-DP2	Cylinder to T1	1 in.	16 ft (4.9 m)	2
			T1 to T2A	1 in.	9 ft (2.7 m)	2
			T2A to Nozzle	3/4 in.	8 ft (2.4 m)	2
			T1 to T2B	1 in.	9 ft (2.7 m)	2
			T2B to Nozzle	3/4 in.	6 1/2 ft (2 m)	2
			T2B to T3	1 in.	6 ft (1.8 m)	2
			T3 to Nozzle	3/4 in.	4 ft (1.2 m)	2

NOTE:

1. These limitations apply to PCI-70ABC using five nozzles (3 NV-WA or NV-SW, 1 NV-P1, and 1 NV-DP2).
2. For systems that have been tested with unbalanced piping, the difference in the length of piping must not exceed 10% of the maximum unbalanced ratio tested.
3. A Main/Reserve Swing Check Valve, Part No. 417788, may be located between the cylinder and T1.
4. All systems protecting vehicle paint spray booths require a factory pre-set time delay.
5. Nozzles located after T3 can only be Models NV-DP2 and NV-P1.
6. When using NV-P1 nozzle, the two largest discharge orifices in the nozzle must be positioned parallel to the longest dimension of the hazard being protected.
- ▶ 7. Maximum height of nozzle from base of tank to nozzle – 20 ft (6.1 m).

Detector Placement

Thermal detectors are required in all hazard areas protected by the PYRO-CHEM Vehicle Paint Spray Booth Industrial Fire Suppression System if automatic system operation is required. Either mechanical or electrical thermal detectors can be used for automatic system operation. Mechanical detectors (fusible links) are used in conjunction with the PYRO-CHEM Models MCH3 and NMCH3 control devices. Electrical detectors are used in conjunction with the PYRO-CHEM Models ECH3-24 and ECH3-120 Control Heads.

TOTAL FLOODING (DETECTOR SPACING) – THERMAL

Ceiling Height	Spacing
Up to 14 ft (4.2 m) Height	15 ft (4.5 m) maximum between detectors 7 ft 6 in. (2.3 m) max. from wall 225 sq ft (20.9 sq m) max. coverage per detector
Greater than 14 ft (4.2 m) up to 20 ft (6.1 m) height	13 ft (3.9 m) maximum between detectors 6 ft 6 in. (1.9 m) max. from wall 169 sq ft (15.7 sq m) max. coverage per detector
Greater than 20 ft (6.9 m) up to 24 ft (7.3 m)	11 ft (3.4 m) max. between detectors 5 ft 6 in. (1.7 m) max. from wall 121 sq ft (11.2 sq m) max. coverage per detector
Greater than 24 ft (7.3 m) up to 30 ft (9.1 m)	9 ft (2.7 m) max. between detectors 4 ft 6 in. (1.4 m) max. from wall 81 sq ft (7.5 sq. m) max. coverage per detector

NOTE: For sloped ceiling (peaked type or shed type) installations, refer to NFPA-72, "National Fire Alarm Code" for detailed spacing requirements.

LOCAL APPLICATION – OVERHEAD (DETECTOR SPACING) – Maximum spacing per detector is 100 ft² (9.3 m²) or 5 ft (1.5 m) from edge of hazard and 10 ft (3.1 m) between detectors. When detectors are mounted below the ceiling in an open area, heat traps are recommended.

LOCAL APPLICATION – TANKSIDE (DETECTOR SPACING) – Detectors can be located either near the inner tank wall and flammable liquid surface or above the tank. If located above the tank, the rules for local application overhead would apply. If located on the tank wall, the detectors can be mounted horizontally or vertically in the freeboard area, but must be protected from damage during normal working operations. The maximum spacing per detector is 5 ft (1.5 m) from edge of hazard and 10 ft (3.1 m) between detectors.

A temperature survey must be performed to determine the maximum ambient temperature of the hazard survey. See Temperature Chart in Chapter 2 – Components.

TOTAL FLOODING (DETECTOR SPACING) – FUSIBLE LINKS

Ceiling Height	Spacing
Up to 12 ft (3.66 m) Height	12 ft (3.66 m) maximum detectors 6 ft (1.83 m) max. from a wall* 144 sq ft (13.38 sq m) max. coverage per detector
Greater than 12 ft (3.66 m) up to 16 ft (4.88 m) height	10 ft (3.05 m) max. between detectors 5 ft (1.52 m) max. from wall 100 sq ft (9.29 sq m) max. coverage per detector
Greater than 16 ft (4.88 m) up to 20 ft (6.1 m) height	8 ft (2.44 m) max. between detectors 4 ft (1.22 m) max. from wall 64 sq ft (5.95 sq m) max. coverage per detector

Note: For sloped ceiling (peaked type or shed type) installations, refer to NFPA-72, "National Fire Alarm Code" for detailed spacing requirements.

LOCAL APPLICATION – OVERHEAD (DETECTOR SPACING) – Maximum spacing per fusible link detector is 36 ft² (3.3 m²) or 3 ft (0.9 m) from edge of hazard and 6 ft (1.8 m) between fusible link detectors.

When a detector(s) is mounted more than 1 ft (0.3 m) below ceiling or in an open area, heat trap(s) is recommended. Detectors should be mounted overhead at nozzle height or as close to the hazard as possible without interference, not to exceed 10 ft (3 m).

Detectors should not be located where they will be susceptible to damage during the normal work operation.

LOCAL APPLICATION – TANKSIDE (DETECTOR SPACING) – Detectors can be located either near the inner tank wall and flammable liquid surface or above the tank. If located above the tank, the rules for local application overhead would apply. If located on the tank wall, the detectors can be mounted horizontally or vertically in the freeboard area but must be protected from damage during normal working operation. Detectors should be located at a maximum spacing per detector of 3 ft (0.9 m) from edge of hazard and 6 ft (1.8 m) between detectors on the long side of the tank.

*For 14 ft (4.3 m) wide booths with maximum height of 12 ft (3.7 m), the detector location off the side wall can be a maximum of 7 ft (2.1 m), and 10 ft (3 m) maximum distance between detectors.

NOTES:

CHAPTER IV SYSTEM INSTALLATION

This chapter will detail the basic information necessary for proper installation of the PYRO-CHEM Vehicle Paint Spray Booth Industrial Fire Suppression System. However, before attempting any installation it is necessary to attend a Factory Certification Training Class and become Certified to install the PYRO-CHEM Vehicle Paint Spray Booth Industrial Fire Suppression System.

Pipe and fittings for the discharge piping, conduit (EMT), pipe straps, pipe hangers, mounting bolts, and other miscellaneous equipment are not furnished as part of the PYRO-CHEM Vehicle Paint Spray Booth Industrial Fire Suppression System. These items must be furnished by the installer.

Before attempting any installation, unpack the entire system and check that all necessary parts are on hand. Inspect parts for damage. Verify that cylinder pressure is within the acceptable range as shown on the gauge.

CYLINDER INSTALLATION

The cylinder and valve assembly is shipped with an anti-recoil plug in the valve discharge port.

CAUTION

The anti-recoil plug must remain in the valve discharge port until the discharge piping is connected to the valve.

The cylinder must be mounted vertically with the discharge port facing either left or right. The Models PCI-15ABC, PCI-17ABC, and PCI-25sABC cylinders must be mounted using a Model MB-15 Mounting Bracket Kit. The Model PCI-35ABC and PCI-70ABC cylinders must be mounted using a Model MB-1 Mounting Bracket Kit.

The bracket must be securely anchored to the wall using bolts or lag screws. The wall to which the bracket is attached must be sufficiently strong to support the cylinder. The bracket should never be fastened to dry wall or similar material. If this type of wall is encountered, studs must be located and the bracket fastened to them. See Figure 4-1.

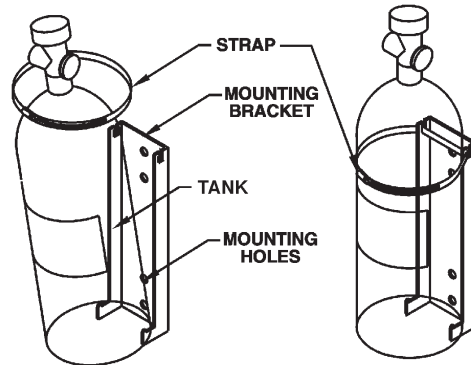

Figure 4-1. Cylinder and Mounting Bracket Installation.

002871PC

CONTROL HEAD INSTALLATION

1. Single Cylinder Installations.

For single cylinder system installations, mount the MCH3/ECH3/NMCH3 Control Head to the bracket. Attach the time delay to the bottom of the control head. After time delay is attached, mount cylinder in its bracket. Then, attach 1/4 in. OD copper tubing or stainless steel actuation hose between time delay outlet and cylinder valve inlet. See

▶ Figure 4-2.

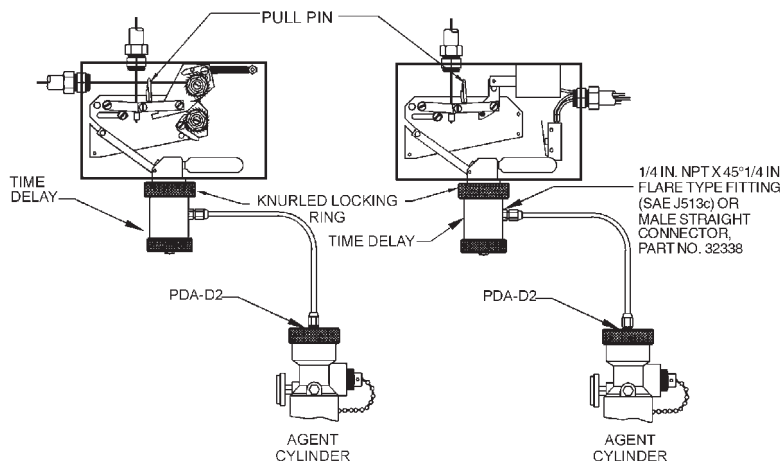

Figure 4-2. Single Cylinder Installation Using Model MCH3/ECH3/NMCH3 Control Head

003153PC

2. Multiple Cylinder Installations.

A. Multiple Cylinder Actuation Using MCH3/ECH3/NMCH3 Control Head.

The Model MCH3/ECH3/NMCH3 Control Head can be used to pneumatically actuate a maximum of five (5) agent cylinders with a 16 gram CO₂ cartridge. The control head must be installed remotely using a Model MB-P2 Control Head Mounting Bracket. The bracket must be anchored to the wall using bolts or lag screws.

CAUTION

Do not screw the control head directly to a wall as this will warp the control head, not allowing the mechanism to actuate.

A time delay must also be attached to the bottom of the control head.

In order to actuate the agent cylinder(s) from the time delay, a 1/4 in. NPT x 45° 1/4 in. flare type fitting (conforming to SAE J513c) or male straight connector (Part No. 32338) must be screwed into the side of the time delay. Also, a Model PDA-D2 Pneumatic Discharge Adaptor must be installed on the valve of each agent cylinder. Pneumatic tubing or stainless steel actuation hose is then used to connect the control head to the PDA-D2 of each agent cylinder valve. See Figure 4-3.

NOTE

Pneumatic tubing used for remote cylinder actuation shall have an outside diameter of 1/4 in. with a minimum wall thickness of 1/32 in. This is commonly known as refrigeration-type copper tubing. All tubing fittings shall be of the 1/4 in., 45° flare type conforming to SAE J513c. **Compression type fittings are not acceptable.**

A single Model MCH3/ECH3/NMCH3 Control Head can actuate:

1. Up to four (4) cylinders with a maximum of 25 ft (7.6 m) of copper or stainless steel pneumatic tubing or stainless steel actuation hose when using an O-ring (Part No. 55531) installed in place of the Teflon washer and the 16 gram CO₂ cartridge.
2. Up to five (5) cylinders with a maximum of 18 ft (5.4 m) of copper or stainless steel pneumatic tubing or stainless steel actuation hose when using an O-ring (Part No. 55531) installed in place of the Teflon washer and the 16 gram CO₂ cartridge.

CAUTION

Confirm the Teflon washer in the control head actuator assembly has been replaced with the O-ring (Part No. 55531) and the 16 gram CO₂ cartridge is installed for 4 and 5 cylinder single control head actuation.

The actuation line must be tested for any leaks by using a hand held or electric vacuum pump. The pump should be used to draw a vacuum on the actuation line at the fitting closest to the control head. A vacuum should be pulled to 20 inches of mercury. Leaks exceeding 5 inches of mercury within 30 seconds are not allowed. If the gauge on the vacuum pump indicates a leak in the line, examine the actuation line for loose fittings or damage. Correct any leaks and retest.

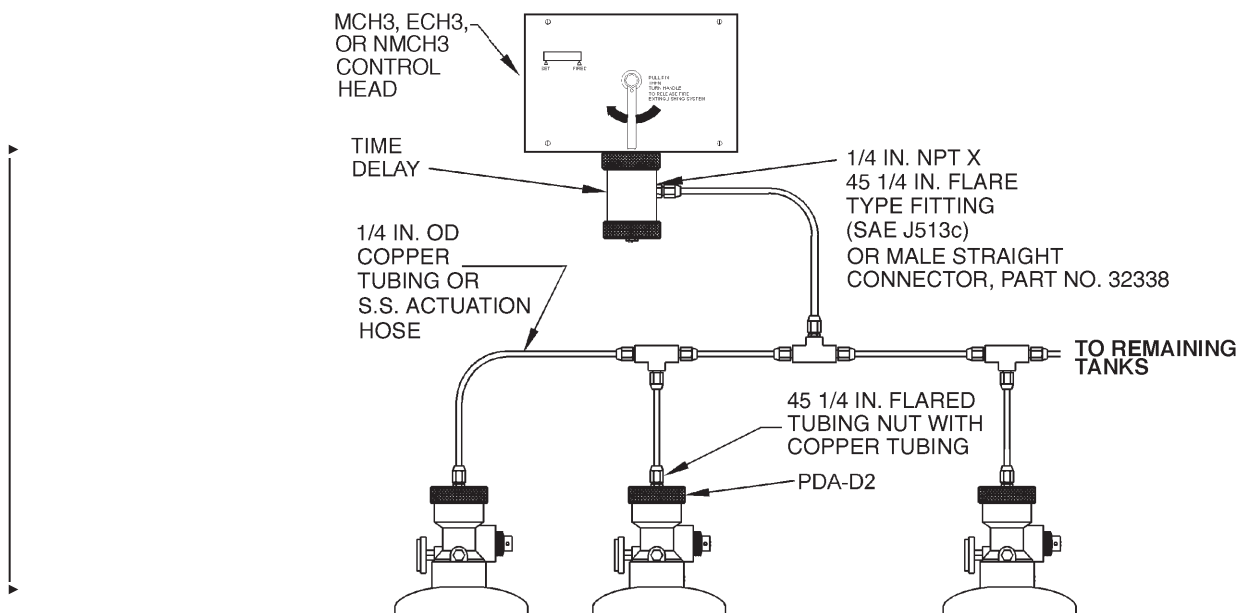

Figure 4-3. Multiple Cylinder Actuation Using Model MCH3/ECH3/NMCH3 Control Head

003154PC

B. Multiple Cylinder Actuation Using Model PAC-10 or PAC-200 Pneumatic Actuation Cylinder.

- The Model PAC-10 or PAC-200 Pneumatic Actuation
- ▶ Cylinder must be used if more than five (5) agent cylinders require simultaneous actuation. The Model PAC-10/200
 - ▶ must be used in conjunction with a Model MCH3/ECH3/NMCH3 Control Head and time delay. The control head and time delay can be connected to the Model
 - ▶ PAC-10/200 valve assembly by using 1/4 in. tubing and fittings or stainless steel actuation hose and fittings.

The Model PAC-10/200 is shipped complete with a mounting bracket. The cylinder must be mounted vertically with the nameplate facing out. The bracket must be securely anchored to the wall using bolts or lag screws. The wall to which the bracket is attached must be sufficiently strong to support the pneumatic cylinder. The bracket should never be fastened to dry wall or similar material. If this type of wall is encountered, studs must be located and the bracket fastened to them. **See Figure 4-4.**

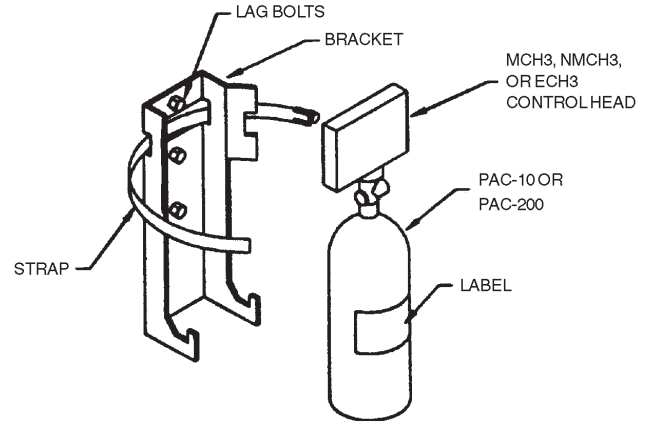

Figure 4-4. Model PAC-10/200 Pneumatic Cylinder Installation

002874PC

- In order to actuate the agent cylinders from a Model PAC-10/200 Pneumatic Actuation Cylinder, a 3/4 in. NPT x 1/4 in. NPT bushing must be screwed into the pneumatic cylinder's discharge port. A 1/4 in. NPT x 45° 1/4 in. flare type fitting (conforming to SAE J513c) must then be screwed into this bushing. The male straight connector (Part No. 32338) is used with stainless steel actuation hose. Also, a Model PDA-D2 Pneumatic Discharge Adaptor must be installed on the valve of each agent cylinder. Pneumatic tubing is then used to connect the PAC-10/200 pneumatic cylinder to the PDA-D2 of each agent cylinder valve. **See Figure 4-5.**

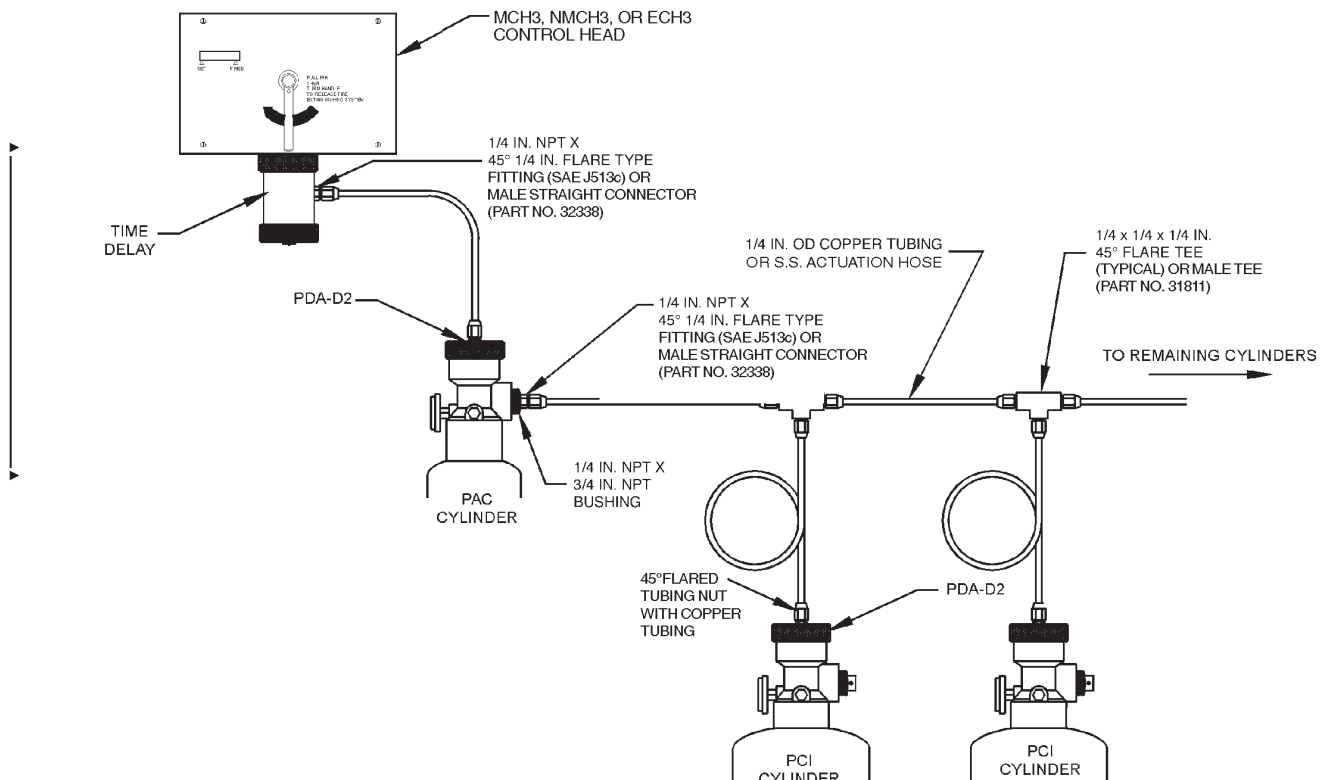

Figure 4-5. Multiple Cylinder Actuation Using Model PAC-10 or PAC-200

003156PC

NOTE

- ▶ Pneumatic tubing used for remote cylinder actuation shall have an outside diameter of 1/4 in. with a minimum wall thickness of 1/32 in. This is commonly known as refrigeration-type copper tubing. All tubing fittings shall be of the 1/4 in., 45° flare type conforming to SAE J513c. **Compression type fittings are not acceptable.**

The Model PAC-10 pneumatic cylinder can actuate a maximum of ten (10) agent cylinders with a maximum of 100 ft (30.5 m) of pneumatic tubing.

The Model PAC-200 pneumatic cylinder can actuate a maximum of twenty (20) agent cylinders with a maximum of 200 ft (61 m) of pneumatic tubing.

C. Multiple Cylinder Actuation Using Two Control Heads.

If the system design requires the use of two control heads for multiple cylinder actuation, a maximum of 25 ft (7.6 m) of tubing or stainless steel actuation hose is allowed between the two control heads and the PAC-10 cylinder. See **Figure 4-5a**. If a PAC-10 cylinder is not utilized, there is a maximum of 25 ft (7.6 m) of tubing or stainless steel actuation hose for the two control heads and up to 4 cylinders or a maximum of 18 ft (5.4 m) of tubing or stainless steel actuation hose for the two control heads and 5 cylinders.

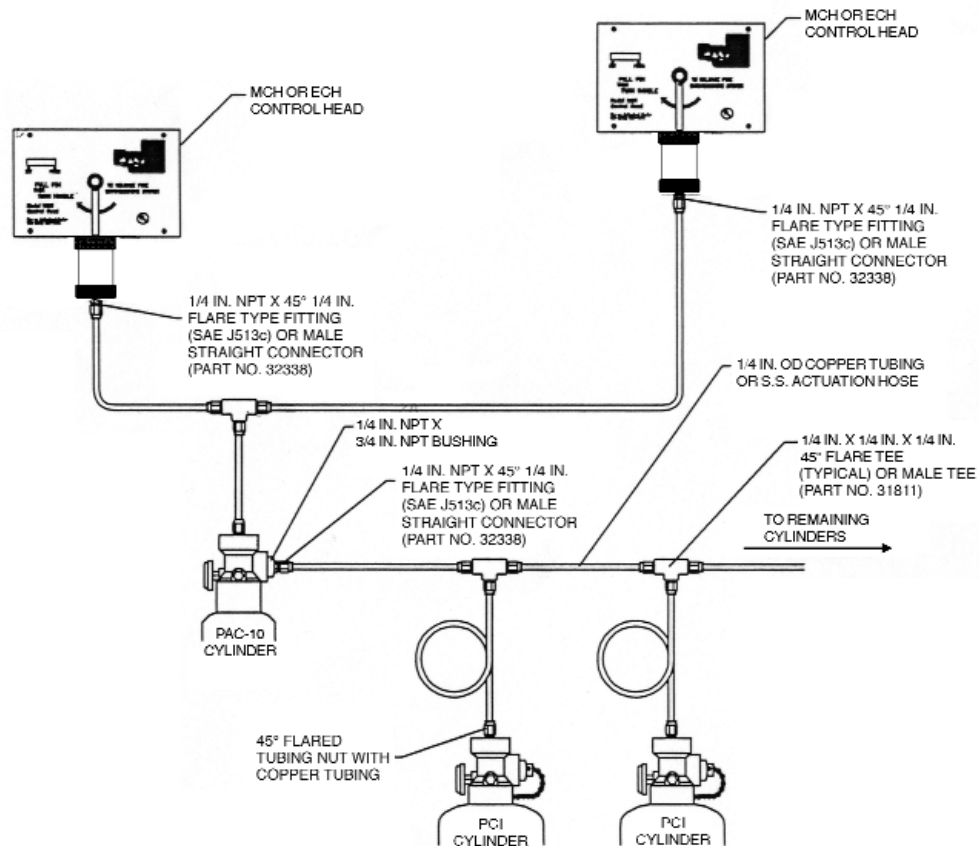

Figure 4-5a. Multiple Cylinder Actuation Using Two Control Heads.

006828

FUSIBLE LINK DETECTOR INSTALLATION

Fusible links are always used in conjunction with the Model MCH3/NMCH3 Mechanical Control Head. After mounting the cylinder and control head, the fusible link line can be installed. The first step to installing the fusible link line is to install the detector bracket(s). These brackets must be installed in the plenum area, the hazard area, and in each duct. See **Chapter III** for detector placement guidelines.

Note: Only ML-style Fusible Links can be used.

- ▶ Connect the fusible link brackets together using 1/2 in. conduit and the conduit connectors supplied in the detector kit (Model FLK-1/1A). A PYRO-CHEM corner pulley must be used whenever a change in conduit direction is necessary. The conduit is connected to the control head through a knockout in the upper left-side corner.

In general, fusible links centered in the detector brackets

- ▶ are connected in series using 1/16 in. diameter stainless steel cable. The spring plate in the control head maintains tension on this series of fusible links. If the tension is released for any reason (i.e., a fusible link separates), the control head will operate and actuate the system. Maximum limitations for the fusible link detection line are as follows:

Fusible links can be installed with or without fusible link hangers (see **Chapter II** for description).

Fusible Link Line Limitations When Used With Model MCH3 and NMCH3 Control Heads and Part No. 415670 and 423250 Pulley Elbows

Maximum # of Detectors:	20
Maximum length of cable:	150 ft (45.7 m)
Maximum # of pulleys:	40

1. Fusible Link Installation Without Hangers.

Begin installing links at the terminal bracket. The link is connected to the far side of the terminal bracket using an “S” hook. The “S” hook must be crimped closed after the link is installed. A tight loop is then made in the cable and secured by the crimp provided. This loop is connected to the other side of the terminal link (see **Figure 4-6**) and the cable fed through the conduit to the next bracket. The cable proceeding from the terminal link will be used to connect the series links (see **Figure 4-7**). Series links must be centered in their detector brackets.

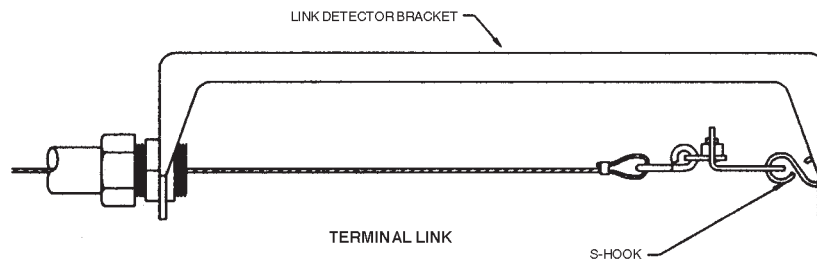

Figure 4-6. Terminal Link Installation.

002849aPC

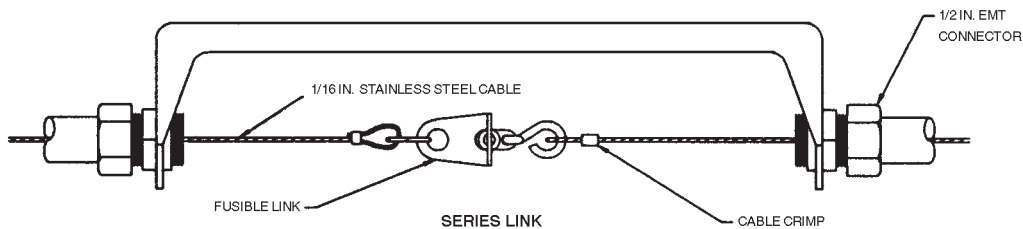

Figure 4-7. Series Link Installation.

002849bPC

After the last link in the series is connected, the cable should be fed through the conduit back to the control head. Thread the cable through the hole in the fusible link ratchet wheel. The line must then be crimped, and the crimp positioned inside the center of the ratchet wheel.

NOTE

Crimps must always be used in conjunction with two (2) cable lengths. Loops are the accepted method of connecting the cable to mechanical components. The crimp must never be used on a single cable. Exception: Single cable crimp allowed in detection and gas valve ratchet wheel using stop sleeve, Part No. 26317 (packages of 10: Part No. 24919).

The fusible link line can now be put into a set position by applying tension to the fusible link line. This is accomplished by using a 1/2 in. hex wrench on the fusible link line ratchet wheel. The ratchet wheel will be ratcheted in a clockwise direction until the spring plate makes contact with the top of the control head box. The fusible link line is now in a set position. See Figure 4-8.

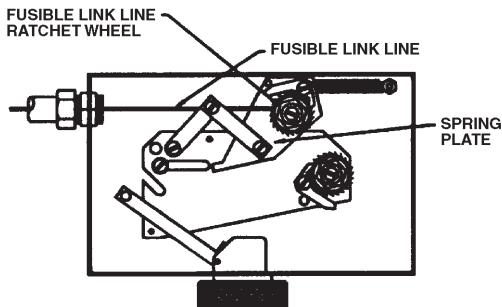

Figure 4-8. Fusible Link Line Termination.
 002876PC

2. Fusible Link Installation Using Model FLH-1 Fusible Link Hangers.

Beginning at the control head, feed the stainless steel cable through the conduit and brackets to the terminal bracket in one continuous length. Allow approximately 2.5 in. (6.4 cm) of slack at each bracket for the installation of the Fusible Link Hangers. At the terminal link, a tight loop is made in the cable and secured by the crimp provided. The cable is attached to the far side of the terminal bracket using an "S" hook. The "S" hook must be crimped closed after the cable is installed. See Figure 4-9.

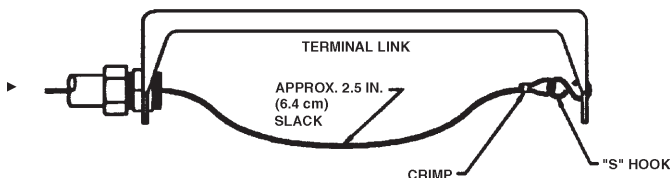

Figure 4-9. Terminal Bracket Connection.
 002877PC

Begin installing the Fusible Link Hangers at the terminal bracket and work toward the control head. Loop the cable through the oval opening in the hanger and hook the fusible link on the loop. See Figure 4-10.

Note: Only ML-style Fusible Links can be used

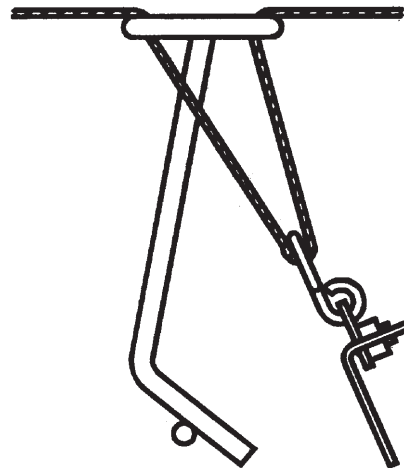

Figure 4-10. Fusible Link Connection.
 002878PC

Hook the bottom of the link onto the bottom leg of the hanger. See Figure 4-11.

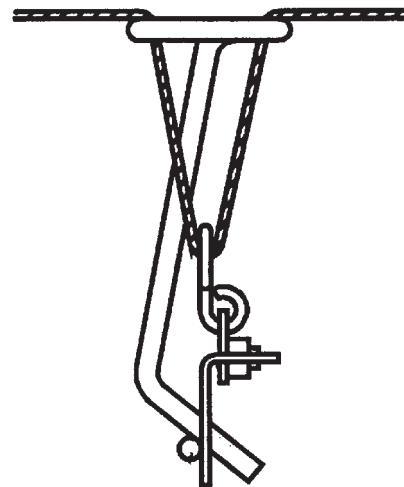

Figure 4-11. Fusible Link/Hanger Connection.
 002879PC

Center the hanger/link in the fusible link bracket by sliding it along the link line. This is easily accomplished before any tension is applied to the link line. Repeat this procedure for all fusible links.

After the last hanger/link in the series is connected, the cable should be fed through the hole in the fusible link ratchet wheel. The line must then be crimped, and the crimp positioned inside the center of the ratchet wheel.

NOTE

Crimps must always be used in conjunction with two (2) cable lengths. Loops are the accepted method of connecting the cable to mechanical components. The crimp must never be used on a single cable.
 Exception: Single cable crimp allowed in detection and gas valve ratchet wheel using stop sleeve, Part No. 26317 (packages of 10: Part No. 24919).

The fusible link line can now be put into a set position by applying tension to the fusible link line. This is accomplished by using a 1/2 in. hex wrench on the fusible link line ratchet wheel. The ratchet wheel will be ratcheted in a clockwise direction until the spring plate makes contact with the top of the control head box. The fusible link line is now in a set position. See **Figure 4-8**. Check to ensure that the fusible link hanger(s) remain centered in the bracket after the fusible link line is set. See **Figure 4-12**.

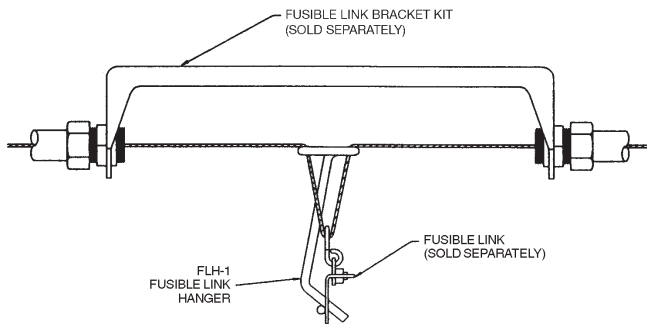

Figure 4-12. Fusible Link/Hanger In Set Position

002850PC

THERMAL DETECTOR INSTALLATION

Thermal detectors are always used in conjunction with the Model ECH3 Electrical Control Head. After mounting the cylinder and control head, the thermal detector(s) can be installed. See **Chapter III** for detector placement guidelines. Follow the instructions included with the detector for proper detector mounting procedures.

SETTING THE CONTROL HEAD

▶ 1. Model MCH3/NMCH3 Mechanical Control Head.

Once the fusible link line is set, the control head can be placed in the set position. To set the control head, the slide plate is moved from right to left, ensuring the bolt extending from the cam arm is in the slot provided in the slide plate. Continue moving the slide plate to the left until the latching arm is in the locked position. Insert the pull pin into the hole in the slide plate above the latching arm. This will lock the

control head in the set position, eliminating accidental actuation during the rest of the installation procedure. See **Figure 4-13**.

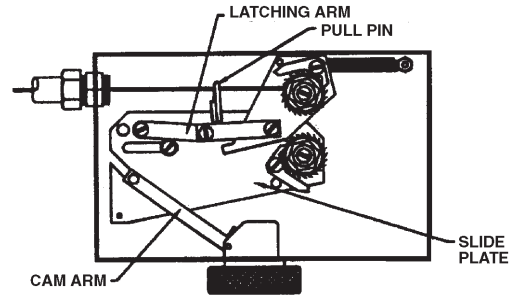

Figure 4-13. Control Head In Set Position.

002880PC

2. Model ECH3 Electrical Control Head.

Once the thermal detectors have been installed, the control head can be placed in the set position. To set the control head, the slide plate is moved from right to left, ensuring the bolt extending from the cam arm is in the slot provided in the slide plate. Continue moving the slide plate to the left until the latching arm is in the locked position. Insert the pull pin into the hole in the slide plate above the latching arm. This will lock the control head in the set position, eliminating accidental actuation during the rest of the installation procedure.

Once the Model ECH Electrical Control Head is in the set position, it can be connected to the detection/actuation circuit.

NOTE

No electrical connections shall be made inside the control head. All electrical wiring shall exit the control head through the knock-out on the side of the box. All electrical connections must be made in an approved electrical box.

Connect one of the black wires on the solenoid in the control head to the red wire of the Model MS-SPDT Micro Switch. The brown wire from the micro switch is then connected to one side of the first thermal detector in series. Connect the other side of the first thermal detector in series and the remaining black wire on the solenoid in the control head to the appropriate power source after installing the Model SM-24/120 Solenoid Monitor.

CAUTION

The solenoid must never be wired "hot" (not through the micro-switch). If wired this way, the non-field replaceable solenoid will be damaged and the complete control head will require replacement.

NOTE

A Model SM-24/120 Solenoid Monitor must always be used with an Electrical Control Head to supervise the actuation/detection circuit.

The Model ECH3-24 Electrical Control Head requires a UL Listed 24VDC power supply with a minimum 2A rating. The Model ECH3-120 Electrical Control Head requires a 1A, 120VAC power supply.

SOLENOID MONITOR INSTALLATION

1. Solenoid Monitor Installation In Detection Circuit.

After installing the thermal detectors and the control head, the Model SM-120/24 Solenoid Monitor can be installed. The Solenoid Monitor is connected to the wires leading from the last thermal detector. It should be mounted in a location where it can be readily observed.

The Solenoid Monitor is an end-of-line device that supervises the actuation/detection circuit. It is comprised of a push-type switch with a built-in indicator light, a plug-type relay, a relay socket, and a cover plate. The light, when illuminated, indicates that the detection/actuation circuit is in the normal condition. The Solenoid Monitor also provides two sets of dry contacts. The Solenoid Monitor's cover plate is used to mount the Solenoid Monitor in a standard 6 in. x 4 in. x 3 in. deep electrical box (See **Figure 4-14**).

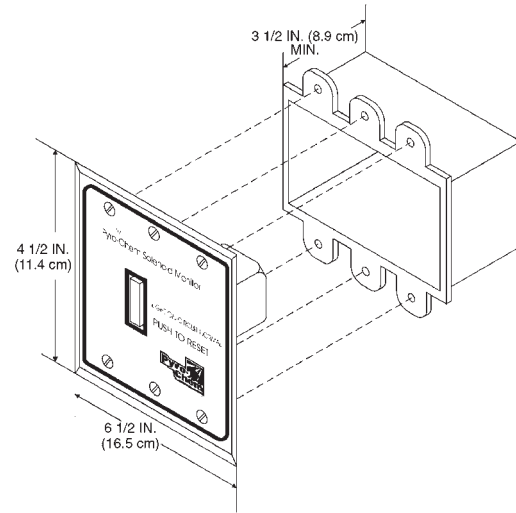

Figure 4-14. Solenoid Monitor Installation.
 002881PC

All wire for circuits using the Model SM-24 shall be 18 gauge minimum, or as required by local code. All wire for circuits using the Model SM-120 shall be 14 gauge minimum, or as required by local code. The basic wiring diagram for both the Model SM-24 and Model SM-120 is shown in **Figure 4-14.1**.

After the Solenoid Monitor has been installed, the detection/actuation circuit can be connected to the appropriate power source and energized. To energize the detector/actuation circuit, depress the switch on the Solenoid Monitor. The light will illuminate to indicate that the circuit is properly installed. If the light fails to illuminate, the wiring must be checked.

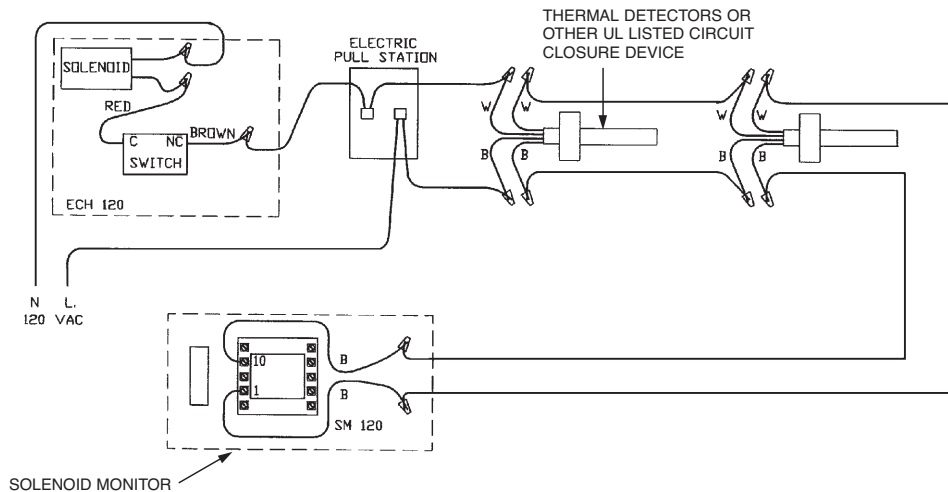

Figure 4-14.1. Wiring Diagram, Solenoid.

002882PC

2. Solenoid Monitor When Used As A Reset Relay

The Model SM-24/120 can be used as a reset relay when required. A reset relay is required whenever an electrical gas shut-off valve is used in conjunction with the PYRO-CHEM Vehicle Paint Spray Booth Industrial Fire Suppression System. For typical wiring connections, see **Figure 4-15**.

REMOTE PULL STATION INSTALLATION

1. Model RPS-M.

The Model RPS-M Remote Mechanical Pull Station is used for remote mechanical actuation of the Model MCH3/ECH3/NMCH3 Control Head. It is to be located near an exit in the path of egress from the hazard area no more than 4 ft (1.2 m) above the floor.

NOTE:

A Model RPS-M Remote Mechanical Pull Station must be used for manual actuation of a Model NMCH3 Releasing Device.

The Pull Station can be surface mounted or recessed. It is connected to the control head using 1/16 in. diameter stainless steel cable. The cable enters the pull station box from the bottom, top, either side, or back. The cable enters the control head through the top-center knockout. The cable must be enclosed in 1/2 in. conduit with a PYRO-CHEM corner pulley at each change in conduit direction. Maximum limitations for the Model RPS-M Remote Mechanical Pull Station are as follows:

**Model RPS-M Cable Run Limitations
 When Used With Model MCH3, ECH3,
 and NMCH3 Control Heads and Part No. 415670
 and 423250 Pulley Elbows**

- ▶ Maximum length of cable: 150 ft (45.7 m)
- ▶ Maximum # of pulleys: 40

After mounting the pull station box and conduit, feed the stainless steel cable from the control head, through the conduit, and into the pull station box. Insert the bushing into the pull station's cover plate and secure it with the locknut provided. Feed the cable through the bushing and into the pull handle ensuring that the cable fully crosses the set screw hole. Fasten the cable to the pull handle with the set screw (see **Figure 4-16**).

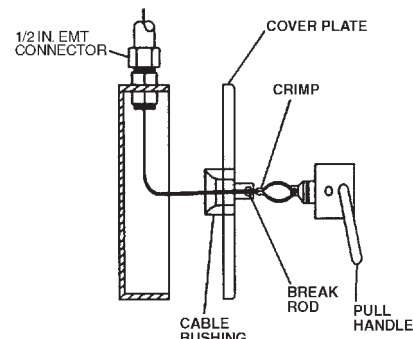

Figure 4-16. Model RPS-M Remote Pull Station Installation.

002884PC

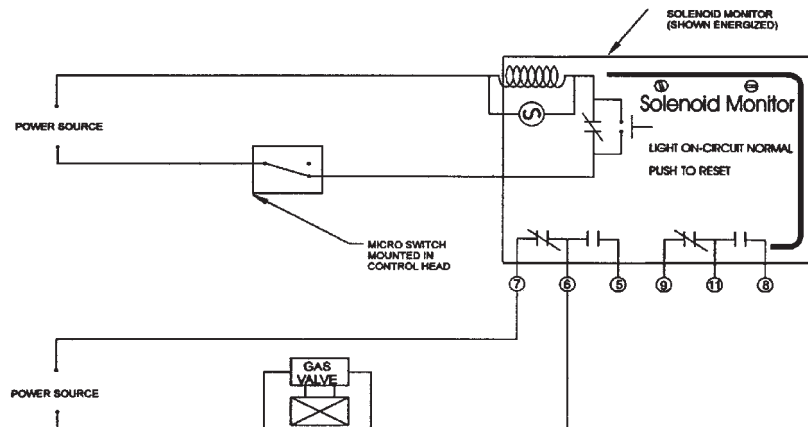

Figure 4-15. Solenoid Monitor Wiring With Electrical Gas Shutoff Valve.

002883PC

NOTE

Crimps must always be used in conjunction with two (2) cable lengths. Loops are the accepted method of connecting the cable to mechanical components. **The crimp must never be used on a single cable.** Exception: Single cable crimp allowed in detection and gas valve ratchet wheel using stop sleeve, Part No. 26317 (packages of 10: Part No. 24919).

Cut and thread the cable through the hole in the latching arm of the control head and pull the cable tight. Crimp the cable 6 in. (15.2 m) below the latching arm.

Pull the pull handle until the crimp touches the latching arm. Coil the excess cable in the pull box and attach the cover plate with the four screws provided. Insert the pull handle into the cover plate and insert the pull pin through the bushing and the pull handle. Secure the pull pin with the nylon tie provided. See Figure 4-17.

2. Model RPS-E2.

The Model RPS-E2 remote electrical pull station is used for remote actuation of the Model ECH3 Control Head. It is to be located near an exit in the path of egress from the hazard area no more than 4 ft. (1.2 m) above the floor. The Model RPS-E2 is installed in the detection/actuation circuit and wired in accordance with the instructions included. See Figure 4-14.1 for typical circuit wiring.

GAS SHUT-OFF VALVE INSTALLATION

1. Mechanical Gas Shut-Off Valve Installation.

The Model MCH3/NMCH3 Control Head is used to operate the mechanical gas shut-off valve. This valve is located in the fuel gas supply line. The valve body has an arrow which indicates direction of gas flow through the valve. The gas shut-off valve is spring loaded and requires five pounds of force to hold it open. This force is supplied by a 1/16 in. diameter stainless steel cable that is connected to the control head. After the valve is installed in the gas line, 1/2 in. conduit must be run from the top center knockout of the gas valve box to the lower right-hand knockout in the control head. A PYRO-CHEM corner pulley is used wherever a change in conduit direction is required.

Gas Valve Cable Run Limitations When Used With Model NMCH3 or MCH3 Control Heads and Part No. 415670 and 423250 Pulley Elbows

Maximum length of cable:	100 ft (30.5 m)
Maximum # of pulleys:	30

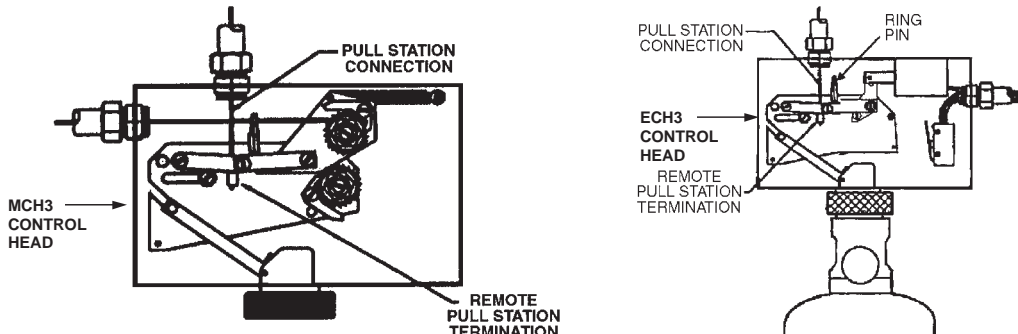

Figure 4-17. Model RPS-M Remote Pull Station Termination.

002885PC/003647PC

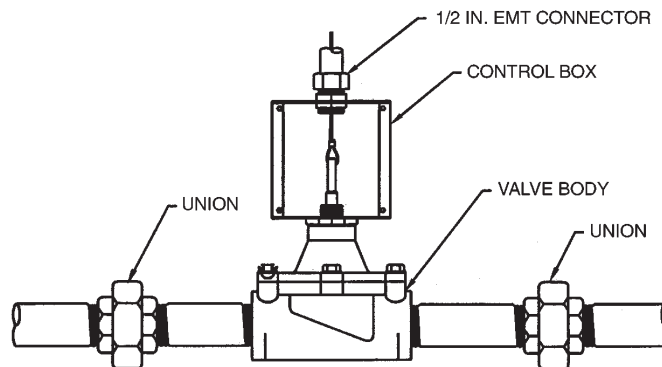

Figure 4-18. Gas Valve Installation.

002886PC

Remove the gas valve cover and thread the stainless steel cable through the conduit back to the control head. Thread the cable through the hole in the gas valve ratchet wheel. The line must then be crimped, and the crimp positioned inside the center of the ratchet wheel.

At the gas valve, loop the cable through the valve stem and secure it with the crimp provided (see **Figure 4-18**).

- ▶ **Note:** See Chapter 2 – Components for maximum dimension to extend valve stem.

The gas valve line can now be put into a set position by applying tension to the gas valve line. This is accomplished by using a 1/2 in. hex wrench on the gas valve ratchet wheel. The ratchet wheel will be ratcheted in a clockwise direction until the gas valve is fully open. Secure the gas valve cover plate to the gas valve box with the four (4) screws provided. The gas valve line is now in a set position. See **Figure 4-19**.

CAUTION

Overtightening the gas valve may cause the system not to actuate.

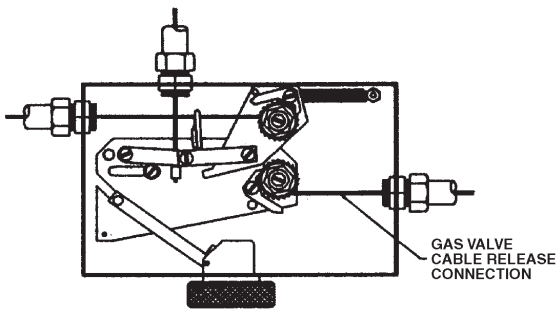

Figure 4-19. Gas Valve Line Termination.

002887PC

2. Electrical Gas Shut-Off Valve Installation.

The Model MCH3/ECH3/NMCH3 Control Head is used to operate the electrical gas shut-off valve. This valve is located in the fuel gas supply line. The valve body has an arrow which indicates direction of gas flow through the valve. A reset relay must always be used with an electrical gas shut-off valve. For proper wiring of the electrical gas shut-off valve, see **Figure 4-15**.

TEE PULLEY INSTALLATION

The Model TP-1 Tee Pulley is used to connect two (2) mechanical gas valves or two (2) remote mechanical pull stations to a single control head. The cable proceeding from the control head must always enter the branch of the tee pulley. See **Figure 4-20**.

A tee pulley that is used to close two (2) gas valves can only be used to close gas valves with similar stem travel. Gas valves from 3/4 in. up to 1 1/2 in. can be used on the same tee pulley. A 2 in. gas valve can be used only with another 2 in. gas valve. Gas valves from 2 1/2 in. up to 3 in. can be used on the same tee pulley. As an example, using a 3/4 in. gas valve with a 3 in. gas valve will not allow the 3 in. valve to fully open.

CAUTION

The tee pulley must never be used to connect multiple fusible link lines to a single control head.

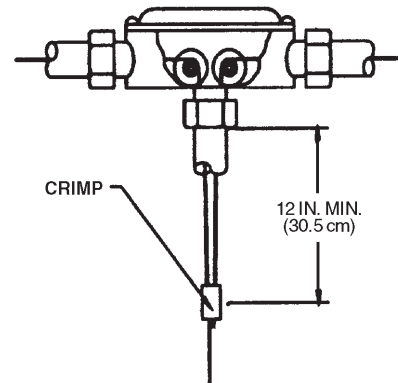

Figure 4-20. Tee Pulley Installation.

002888PC

MICRO SWITCH INSTALLATION

See NFPA 72, "National Fire Alarm Code," Initiating Devices section, for the correct method of wiring connection to the fire alarm panel.

The Model MS-SPDT, MS-DPDT, MS-3PDT, or MS-4PDT Micro Switch is available for use where an electrical output is required. These switches can be field installed in the control head. See **Figure 4-21** and **Figure 4-22** and refer to Installation Sheet, Part No. 551159, included with switch shipping assembly, for detailed mounting instructions.

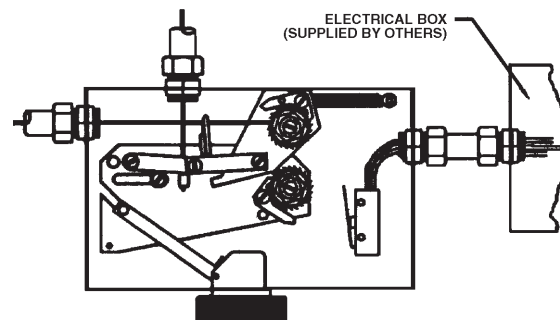

Figure 4-21. Micro Switch Installation in Model MCH3/NMCH3 Control Head.

002889PC

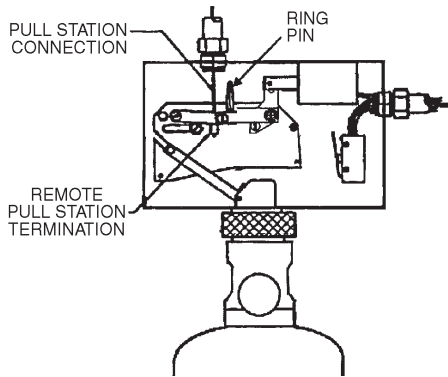

Figure 4-22. Micro Switch Installation in Model ECH3 Control Head.

003647PC

NOTE

The Model ECH3 Control Head is supplied with a Model MS-DPDT Micro Switch. This switch can be used in the actuation/detection circuit and for electrical output.

These switches may be used to provide an electrical signal to the main breaker and/or operate electrical accessories provided the rating of the switch is not exceeded. Wiring connections are shown in **Figure 4-23**. The contact ratings for the switches are as follows:

Contact Ratings For Micro Switches

21 amps, 1 HP, 125, 250, 277 VAC
 or 2 HP, 250, 277 VAC

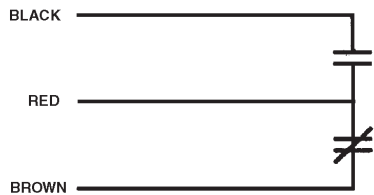
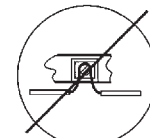
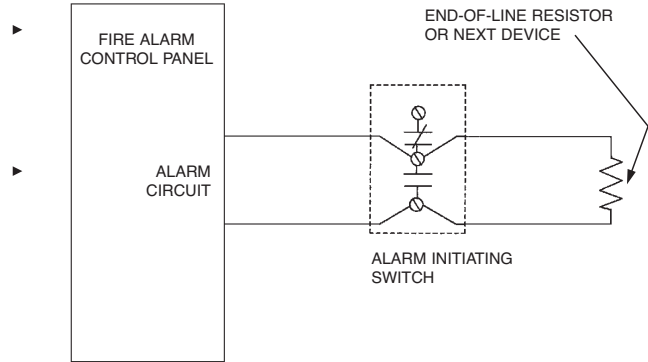

Figure 4-23. Wiring Diagram For Model MS-SPDT Micro Switch.

002903PC

The Alarm Initiating Switch, Part No. 550077, must be used to close a supervised alarm circuit to the building main fire alarm panel when the control head actuates. This will signal the fire alarm panel that there was a system actuation in the hazard area. This switch can be field installed in the control head. Refer to Instruction Sheet, Part No. 550081, included with the switch shipping assembly, for detailed mounting instructions. Wiring connections are shown in **Figure 4-24**. The switch is rated at 50mA, 28VDC.



INCORRECT

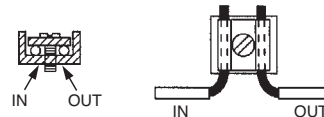

CORRECT – SEPARATE INCOMING AND OUTGOING CONDUCTORS

Figure 4-24. Wiring Diagram for Alarm Initiating Switch.

004891/004905

PIPE AND NOZZLE INSTALLATION

General Piping Requirements

1. Use Schedule 40 black iron (if used in a relatively non-corrosive atmosphere), galvanized, chrome-plated, or stainless steel pipe conforming to ASTM A120, A53, or A106. Fittings must be a minimum of 150 lb Class. However, the PCI 35, 50, and 70 lb cylinders must have a minimum of two (2) nozzles per cylinder to utilize the 150 lb Class fittings. If the PCI 35, 50, or 70 lb cylinder has one (1) nozzle, then a 300 lb Class fitting must be used. The remaining Monarch cylinders have no limitations for the 150 lb Class fittings. Distribution pipe sizes are 3/4 in. or 1 in. depending on number of nozzles.
2. Pipe unions are acceptable.
3. Use reducing tees for all pipe splits.
4. Reducing bushings are not acceptable.
5. Cast iron pipe and fittings are not acceptable.
6. **Pipe thread sealant or pipe joint compound is not allowed for distribution piping.**
7. Bell Reducer or any non-restrictive fittings are allowed.
8. Before assembling the pipe and fittings, make certain all ends are carefully reamed and blown clear of chips and scale. Inside of pipe and fittings must be free of oil and dirt.

- ▶ 9. If Teflon tape is used on threaded ends, start at the second male thread and wrap the tape clockwise around the threads, away from the pipe opening.
- ▶ 10. All system piping must comply with Section A-5-9.1 of NFPA-17.

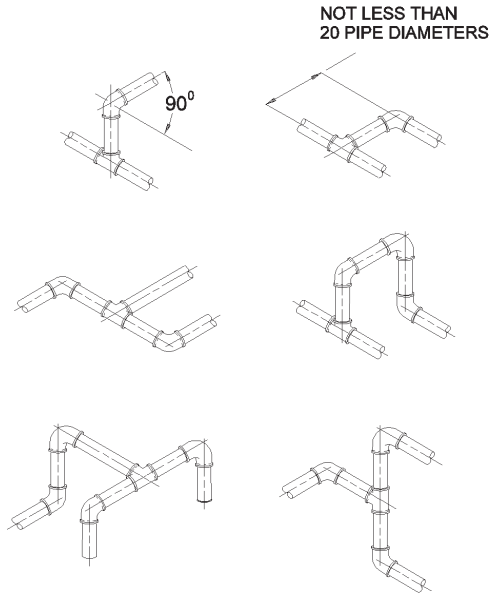

▶ **Figure 4-25. Acceptable Piping Methods.**

002965PC

CAUTION

Do not apply Teflon tape to cover or overlap the pipe opening, as the pipe and nozzles could become blocked and prevent the proper flow of agent

▶ **TEE POSITIONING**

In order to obtain equal distribution at a tee, the dry chemical must enter the side port of the tee and exit through the two end ports. See **Figure 4-26**.

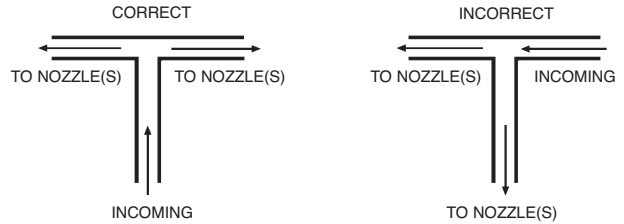

Figure 4-26. Tee Positioning

003126

Hanger/Support Installation

The hanger/supports must be installed in conjunction with the pipe and fittings. The spacing requirements for hangers/supports depend on the pipe size being utilized; refer to the Spacing Guidelines Chart.

PIPE HANGER SPACING GUIDELINES CHART

Distribution Pipe Size	Maximum Spacing Distance Hanger to Hanger	
	ft	m
▶ 1/4	4	(1.2)
▶ 1/2	6	(1.8)
▶ 3/4	8	(2.4)
▶ 1	12	(3.6)

Other factors that influence hanger/support spacing are:

- ▶ Hanger/Support must be placed within 1 ft (0.3 m) of the discharge nozzle.

Hanger/Support must be placed between elbows when distance is greater than 2 ft (0.6 m).

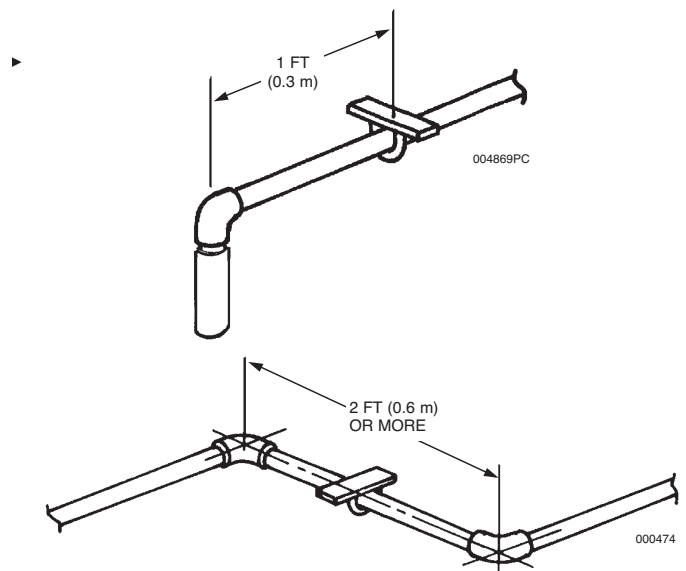

▶ **Figure 4-27. Hanger/Support.**

MAIN/RESERVE SYSTEM

When a reserve system is being utilized, two 1 in. swing check valves, Part No. 417788, must be installed in the distribution piping network. They should be positioned as close as possible to the “Y” fitting joining the piping from the main and reserve tanks to one common supply pipe. See **Figure 4-28**. **Note:** Make certain to install swing check valves in the direction of dry chemical flow as shown with an arrow stamped on the valve body.

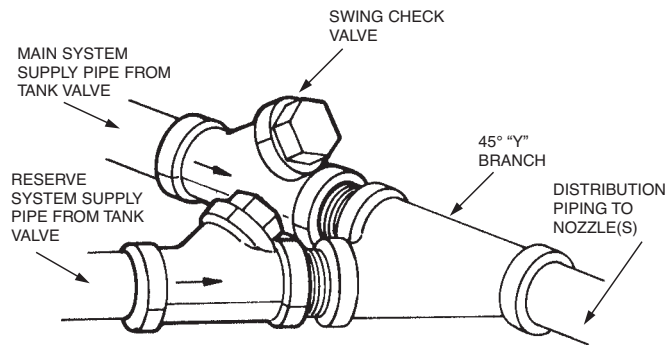

Figure 4-28. Main/Reserve System.

000480

PRESSURE SWITCH INSTALLATION

The Model PS-SPDT-X Pressure Switch is available for use when an electrical output is required. It must be installed in the discharge piping within 12 in. (30.5 cm) of the valve discharge port as shown in **Figure 4-29**. An inline tee is used for the installation. The switch is isolated from the chemical by a 12 in. to 15 in. (30.5 to 38.1 cm) column of air in the form of a vertical pipe nipple. The switch is then mounted at the top of this nipple.

NOTE

Piping for pressure switch must be included in total cylinder to T1 piping limitations. The fitting used to connect the pressure switch to the distribution piping counts as one (1) elbow in that section.

As an alternate, the switch may be connected directly to the copper tubing of a remotely mounted control head or a PAC cylinder. The PS-SPDT-X counts as one cylinder in this section, and the limitations on copper tubing and/or pipe previously stated in this manual apply.

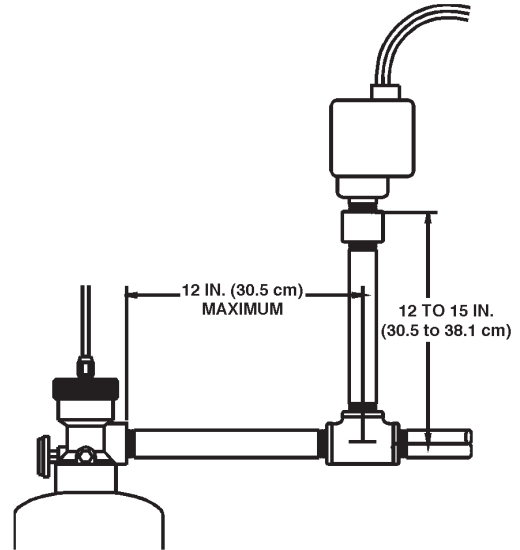

Figure 4-29. Pressure Switch Installation.

003025PC

SYSTEM CHECKOUT AFTER INSTALLATION

1. Model MCH3/NMCH3 Mechanical Control Head.

Before putting the system into service, all components must be checked for proper operation. During this checkout, assure that the carbon dioxide pilot cartridge is not installed in the control head actuator. Remove the pull pin from the hole in the slide plate.

To check satisfactory operation of the control head, cut the terminal link or the “S” hook holding the link. This will relieve all tension on the fusible link line and operate the control head. The slide plate will move fully to the right. The gas valve cable will be released, causing the gas valve to close. Any auxiliary equipment connected to the dry contacts of the solenoid monitor and/or the Micro Switch in the control head will operate.

If any of these events fail to occur, the problem must be investigated and repaired.

Repair the terminal link and put the fusible link line back into the set position. This is accomplished by using a 1/2 in. hex wrench on the fusible link line ratchet wheel. The ratchet wheel will be ratcheted in a clockwise direction until the spring plate makes contact with the top of the control head box.

Once the fusible link line is set, the control head can be placed in the set position. To set the control head, the slide plate is moved from right to left, ensuring the bolt extending from the cam arm is in the slot provided in the slide plate.

Continue moving the slide plate to the left until the latching arm is in the locked position.

Once the control head is set, pull the pull handle on the remote pull station to assure that the control head operates. If the control head operates normally, the control head can be reset as described above. Insert the pull pin into the hole in the slide plate above the latching arm. Replace the pull station handle, pull pin, and nylon tie.

Assure that the gas valve is fully open by ratcheting the gas valve ratchet wheel.

Using a felt-tipped marker, write the date of installation on the carbon dioxide pilot cartridge. Screw the cartridge into the control head actuator until hand-tight. **Never use a wrench to tighten the cartridge into the actuator.**

Remove the pull pin from the hole in the slide plate and install the control head cover. Insert the pull pin through the local manual control handle and into the bushing. Secure the pull pin with the nylon tie provided.

2. Model ECH3-24/120 Electrical Control Head.

Before putting the system into service, all components must be checked for proper operation. During this checkout, ▶ assure that the CO₂ pilot cartridge is not installed in the control head actuator. Remove the pull pin from the hole in the slide plate.

CAUTION

Make certain to remove the CO₂ cartridge. Failure to do so during testing will result in system actuation.

Testing Thermal Detectors

1. Remove the electric control head cover.
2. Test each detector individually and recock release mechanism after each test.

- ▶ 3. Using a heat gun positioned approximately 12 in. from the detector, apply heat to the detector for about one minute. Overheating will cause damage to the detector. Applying heat to the detector will cause the control head to operate. When the control head operates, the following will take place: a) The slide plate will move fully to the right; b) The indicator light on the solenoid monitor will go out; and c) Any auxiliary equipment connected to the dry contacts of the solenoid monitor and/or the micro switch in the control head will operate. If any of these events fail to occur, the problem must be investigated and repaired.
4. After all the thermal detectors have cooled, the control head can be placed in the set position. To set the control head, the slide plate must be moved from right to left, ensuring the bolt extending from the cam arm is in the slot provided in the slide plate. Continue moving the slide plate to the left until the latching arm is in the locked position.

Testing Remote Pull Station

1. Once the control head is set, pull the pull handle on the remote pull station to assure that the control head operates. If the control head operates normally, the control head can be reset as described in Step 4 above.
2. Insert the pull pin into the hole in the slide plate above the latching arm.
- ▶ 3. Replace the pull station handle, pull pin, and break rod.

▶ Completing System Checkout

- ▶ 1. Energize the actuation/detection circuit by depressing the push button on the solenoid monitor.
- ▶ 2. Using a felt-tipped marker, write the date of installation on the CO₂ pilot cartridge. Ensure that the actuator has an O-ring installed, and screw the cartridge into the control head actuator until hand tight. **Never use a wrench to tighten the cartridge into the actuator.**
- ▶ 3. Remove the pull pin from the hole in the slide plate and install the control head cover. Insert the pull pin through the local manual control handle and into the bushing. Secure the pull pin with the tie provided.

NOTE

Refer to NFPA-17 for additional inspection requirements.

NOTES:

CHAPTER V SYSTEM MAINTENANCE

GENERAL

This chapter will detail the basic information necessary for proper maintenance of the PYRO-CHEM Industrial Fire Suppression System. However, before attempting any system maintenance, it is necessary to attend a Factory Certification Training Class and become Certified to install and maintain the PYRO-CHEM Vehicle Paint Spray Booth Industrial Fire Suppression System.

MAINTENANCE AFTER SYSTEM DISCHARGE

1. System Cleanup.

The hazard area cleanup after a system discharge is very basic. The dry chemical agent should be cleaned up by either sweeping or vacuuming. Residual dry chemical should be wiped off effected surfaces with a damp cloth.

2. System Cylinder Recharge.

CAUTION

Protective eye goggles and protective footwear must be worn when performing system maintenance.

1. Remove the cylinder from the control head or pneumatic adaptors and inspect for visual damage. If there is any damage the cylinder must be hydrostatically tested before being refilled. If there is no damage, the cylinder can be recharged.
2. Reset all pneumatic actuators (Models PDA-D2) by depressing the check valve on top and relieving the pressure. Remove the pneumatic actuator or control head from the valve and use any 1/4-20 UN screw or bolt to screw into the top of the piston. Pull up on the piston until the piston is flush with the top of the valve body and remove the screw or bolt from the piston.
3. Remove the valve and siphon tube assembly from the cylinder and unscrew the siphon tube from the valve.
4. Inspect the valve to make sure no mechanical damage has occurred. If there is evidence of any damage to the seals, rebuild the valve using the Dry Valve Rebuilding Kit (PYRO-CHEM Part No. 550037).
5. Screw the siphon tube back into the valve.

6. Refill the cylinder with agent. Use the table below for easy reference.

<u>Cylinder</u>	<u>Recharge</u>
PCI-15ABC	12.5 lb ABC (Part No. 550696)
PCI-17ABC	17 lb ABC (Part No. 550696)
PCI-25sABC	25 lb ABC (Part No. 550696)
PCI-35ABC	35 lb ABC (Part No. 550696)
PCI-70ABC	70 lb ABC (Part No. 550696)

The Model RC-50ABC (Part No. 550696) is a 50 lb pail of ABC dry chemical recharge agent available from PYRO-CHEM.

7. Insert the siphon tube into the cylinder, and screw the valve onto the cylinder. Make sure that the valve is screwed completely into the cylinder.
8. Attach the Recharge Adaptor (PYRO-CHEM Part No. 550130) to the discharge port of the valve. The adaptor O-ring should be completely inside the discharge port. Attach a source of dry nitrogen to the adaptor.

Charge the cylinder with dry nitrogen to 350 psi at 70°F.

NOTE

1. The pressure gauge attached to the cylinder valve should not be used to determine when the charging pressure has been reached. A pressure regulator should be used.
 2. Higher pressure may be needed during the initial charging stage to blow the agent out of the siphon tube. Secure the cylinder during this stage, as it may jump as the agent is blown from the siphon tube.
9. Slowly disconnect the nitrogen source from the Recharge Adaptor. The cylinder valve will close when the Recharge Adaptor is depressurized. When the valve is closed and the nitrogen source is disconnected from the Recharge Adaptor, remove the recharge adaptor from the valve discharge port. Immediately screw the recoil preventer into the discharge port.

CAUTION

The recoil preventer must remain in the valve discharge port until the cylinder is attached to the piping network.

10. Reinstall the cylinder to the piping network. Reattach the control head or pneumatic adaptor.

3. Piping and Nozzles.

- ▶ Piping should be blown out with air or dry nitrogen. Nozzle blow off caps should be replaced.

4. System Reset.

All fusible links should be replaced. The fusible link line can now be put into a set position by applying tension to the

- ▶ fusible link line. This is accomplished by using a 1/2 in. hex wrench on the fusible link line ratchet wheel. The ratchet wheel will be ratcheted in a clockwise direction until the spring plate makes contact with the top of the control head box. The fusible link line is now in a set position.

After setting the fusible link line, the system can be put back into service by following the SYSTEM CHECKOUT AFTER INSTALLATION Section of **Chapter IV**.

REGULAR SYSTEM MAINTENANCE

1. Six (6) Month Maintenance.

1. Check that the hazard has not changed.
 2. Check that all nylon ties are in place and the system has not been tampered with.
 3. Check the entire system for mechanical damage.
- ▶ 4. Check the solenoid monitor
 - ▶ 5. Disconnect the control head or pneumatic tubing from each agent cylinder. Remove the carbon dioxide pilot cartridge and exercise the control head to ensure it is functioning properly. Make sure the gas shut-off valve and the remote pull station are functioning properly.

NOTE

Before continuing, remove the cover from the control head and insert the pull pin in the hole in the slide plate above the latching arm. This will secure the system, preventing accidental discharge.

- ▶ 6. Inspect fusible link detectors for excessive grease buildup. Clean or replace links if necessary. Visually inspect thermal detectors.

NOTE

Methods and frequency of inspection, testing and maintenance of detectors should be in accordance with NFPA-72.

- ▶ 7. Reinstall the carbon dioxide pilot cartridge and replace the control head cover and nylon tie.

CAUTION

Before screwing the carbon dioxide pilot cartridge into the actuator, ensure that the actuator has an O-ring installed.

- ▶ 8. Inspect the cylinder pressure. Tap the gauge lightly to ensure the needle is moving freely. If the gauge shows a loss in pressure indicated by the needle being below the green band, the tank should be removed and recharged per the SYSTEM CYLINDER RECHARGE section of Chapter V (System Maintenance) in this manual.

2. Annual Maintenance.

1. Inspect as per six (6) month maintenance instructions.
 2. Disconnect and remove the discharge piping from the system. Using air or nitrogen, blow out the discharge piping. Replace all nozzle caps.
- ▶ 3. Fixed temperature sensing elements of the fusible alloy type shall be replaced at least annually or more frequently, if necessary, to assure proper operation of the system.
 - ▶ 4. Test thermal detectors and remote pull station per SYSTEM CHECKOUT AFTER INSTALLATION section located in Chapter IV (System Installation) of this manual. Per NFPA 72, two (2) or more detectors per circuit should be tested. Note individual detector location and date of testing. Within 5 years, all detectors in system must be tested.
 - ▶ 5. Replace the carbon dioxide pilot cartridge, recording the date of installation on the cartridge with a felt-tipped marker.

CAUTION

Before screwing the carbon dioxide pilot cartridge into the actuator, ensure that the actuator has an O-ring installed.

3. Six (6) Year Maintenance.

1. Inspect as per annual maintenance instructions.
2. Examine the dry chemical. If there is evidence of caking, the dry chemical shall be discarded.

4. Hydrostatic Testing.

The dry chemical agent cylinder(s) and pneumatic cylinder(s) shall be hydrostatically tested at least every twelve (12) years as per NFPA-17.

NOTE

- ▶ Refer to NFPA-17 for additional maintenance requirements.

**MONARCH™ INDUSTRIAL
FIRE SUPPRESSION
SYSTEM**



by Tyco Fire Suppression & Building Products

OPEN FACE PAINT SPRAY BOOTH PROTECTION

TECHNICAL MANUAL

- **COMPONENTS**
- **DESIGN**
- **INSTALLATION**
- **MAINTENANCE**

Copyright © 2010 Tyco Fire Suppression & Building Products

Revised February 1, 2010

TABLE OF CONTENTS

<u>Page</u>	<u>Subject</u>	<u>Revision</u>	<u>Date</u>	<u>Page</u>	<u>Subject</u>	<u>Revision</u>	<u>Date</u>
General Information				Design (Continued)			
1-1	General Information	2	2/1/10	3-3	Piping Limitations – PCI-15ABC w/1 Nozzle	2	3/17/04
Components				3-4	Piping Limitations – PCI-25sABC w/2 Nozzles	3	9/1/06
2-1	Cylinders & Valve	2	3/17/04	3-4.1	Protecting Duct and Plenum	New	2/1/10
2-2	Nozzles	3	2/1/10	3-4.2	Notes	New	2/1/10
	Cylinder Bracketing			3-5	Piping Limitations – PCI-35ABC w/4 Nozzles	3	9/1/06
	MCH3 Control Head			3-6	Piping Limitations – PCI-70ABC w/6 Nozzles PCI-70ABC w/8 Nozzles	3	9/1/06
2-3	ECH3 Control Head	2	3/17/04	3-7	Local Application – Overhead	2	3/17/04
	NMCH3 Control Head			3-8	Piping Limitations – PCI-25sABC w/2 Nozzles	2	9/1/06
	MB-P2 Mounting Bracket			3-9	Piping Limitations – PCI-50sABC w/4 Nozzles	2	9/1/06
	PDA-D2 Adaptor			3-10	Protecting Duct and Plenum on Local Application Systems	2	9/1/06
2-4	Pneumatic Actuating Cylinders	2	3/17/04		Piping Limitations – PCI-35ABC w/3 Nozzles		
PAC-10			3-11	Detector Placement	4	2/1/10
PAC-200			Installation			
2-5	Detection Equipment	2	3/17/04	4-1	General	2	3/17/04
FLK-1				Cylinder Installation		
FLK-1A				Control Head Installation –		
FLH-1			Single Cylinder		
2-6Fusible Links	4	2/1/10	4-2Multiple Cylinder Installation	3	3/17/04
Thermal Detectors			4-3Multiple Cylinder –	2	3/17/04
	RPS-M Remote Pull Station				PAC-10 or PAC-200		
2-7	RPS-E2 Electric Pull Station	3	9/1/06	4-4Multiple Cylinders – Two	2	3/17/04
	Gas Shut-off Valves				Control Heads		
Mechanical			4-5	Fusible Link Detector Installation	2	3/17/04
Electrical			Fusible Links Without		
2-8	Corner Pulleys	2	3/17/04		Hangers		
SBP-1			4-6Fusible Links With Hangers	2	3/17/04
CBP-1			4-7	Thermal Detector Installation	2	3/17/04
WBP-1				Setting The Control Head		
	Tee Pulley			MCH3/NMCH3 Control Head		
	Swing Check Valve			ECH3 Control Head		
2-9	Electrical Switches	3	9/1/06	4-8	Solenoid Monitor Installation	2	3/17/04
Micro			In A Detection Circuit		
Alarm Initiating			4-9When Used as a Reset	2	3/17/04
	SM-120/24 Solenoid Monitor				Relay		
2-10	Stainless Steel Actuation Hose	2	3/17/04		Remote Pull Station Installation		
	Pipe and Fittings			RPS-M		
	Pressure Switches			4-10RPS-E2	3	9/1/06
	Pressure Bleed Down Adaptor				Gas Shut-off Valve Installation		
2-11	Component List	3	2/1/10	Mechanical		
2-12	Component List (Continued)	2	3/17/04	4-11Electrical	3	3/17/04
Design					Tee Pulley Installation		
3-1	General	3	9/1/06		Micro Switch Installation		
	Choosing the Proper Agent			4-12	Pipe and Nozzle Installation	3	9/1/06
	Choosing the Proper Type of System			4-13	Tee Positioning	2	3/17/04
	Total Flooding						
Cylinders						
Nozzles						
Temperature Range						
3-2Piping Requirements	4	2/1/10				
Nozzle Placement						
Nozzle Coverages						

► Indicates revised information

■ Indicates no change to text – change in page sequence only

<u>Page</u>	<u>Subject</u>	<u>Revision</u>	<u>Date</u>	<u>Page</u>	<u>Subject</u>	<u>Revision</u>	<u>Date</u>
Installation (Continued)							
4-14	Main/Reserve System Pressure Switch Installation System Checkout After InstallationMechanical Control Head	2	3/17/04				
4-15Electrical Control Head		3/17/04				
4-16	Notes		3/17/04				
Maintenance							
5-1	General Maintenance After DischargeSystem CleanupSystem Cylinder Recharge	3	2/1/10				
5-2Piping and NozzlesSystem Reset Regular System Maintenance6 Month MaintenanceAnnual Maintenance6 Year MaintenanceHydrostatic Testing	2	3/17/04				

CHAPTER I

General Information

INTRODUCTION

PYRO-CHEM Open Face Paint Spray Booth automatic dry chemical fire suppression system is of the pre-engineered type as defined by the NFPA Standard for Dry Chemical Extinguishing Systems, NFPA-17. The extinguishing units described in this manual are intended to be installed, inspected, and maintained in accordance with NFPA-17. Limitations detailed in this manual have been established through extensive testing by Underwriters Laboratories, Inc. Installation and maintenance of the system must conform to the limitations detailed in this manual and be performed by an Authorized PYRO-CHEM dealer.

The PYRO-CHEM Open Face Paint Booth System utilizes a monoammonium phosphate based dry chemical agent (specifically designed to suppress carbonaceous solid, liquid, gas or electrical fires). The system provides mechanical or electrical automatic actuation and can be manually actuated through a remote mechanical pull station. Upon actuation, the system discharges a pre-determined amount of agent to the hazard area.

The shutdown of fuel and power to the hazard area is required upon system actuation. Exhaust fan(s) in the ventilation system must be shut off during system discharge to allow the proper concentration of agent to build up in the hazard area.

TEMPERATURE LIMITATIONS

The operating temperature range of the PYRO-CHEM Open Face Paint Booth System is 32 °F (0 °C) minimum to 120 °F (49 °C) maximum.

UL LISTING

The PYRO-CHEM Open Face Paint Booth Industrial Fire Suppression System has been tested to the UL Standard for Pre-Engineered Dry Chemical Extinguishing System Units, UL1254 (Revised Sept. 29, 1998), and Listed by Underwriters Laboratories, Inc.

▶ CITY OF NEW YORK APPROVAL

The PYRO-CHEM Open Face Paint Spray Booth Fire Suppression System is approved by the City of New York Fire Department per Certificate of Approval No. 5544 under the following conditions:

1. Prior to installation, plans must be filed with and accepted by New York City Department of Buildings. Additionally, a copy of New York City Department of Buildings docketed plans shall be transmitted to the Fire Department for review and approval.
2. The system shall be installed, periodically inspected, tested and otherwise maintained in accordance with Sections 901, 904.1.1 and 904.4 of New York City Fire Code, NFPA 17 and all applicable New York City Construction Code/Fire Code. Electrical wiring shall be in accordance with the New York City Electrical Code.
3. At least once a month, an inspection shall be conducted by a trained and knowledgeable person to assess that the system is in good working order.
4. The installation, maintenance procedures, and limitations stated in this manual must be complied with.

CHAPTER II COMPONENTS

CYLINDERS & VALVE

PYRO-CHEM Open Face Paint Spray Booth automatic dry chemical systems are supplied in 15 pound, 25 pound, 35 pound, 50 pound, and 70 pound capacity cylinders. They are the Models PCI-15ABC, PCI-25sABC, PCI-35ABC, PCI-50sABC, and PCI-70ABC. Each cylinder must be separately piped to its own nozzles. All models are charged with dry nitrogen to 350 psi @ 70° F. **These systems are for indoor hazard protection only.**

The valve shown in Figure 2-2 is a pressure sealed, poppet type valve. It is on all cylinders and also the PAC-10 and the PAC-200 cylinders. The valve discharge port is 3/4 in. NPT.

All are rated to protect "A," "B," and "C" Class Hazards.

The dimensions of the cylinders and valve assemblies are shown in **Figure 2-1**. The cylinder is manufactured, tested, and marked in accordance with **DOT** specification 4BW350.

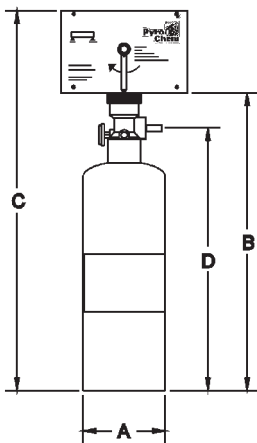

MODEL NO.	A	B	C	D	WEIGHT	MOUNTING BRACKET USED
PCI-15ABC	6.00	21.44	27.19	18.69	30 lb	MB-15
PCI-25sABC	8.00	24.81	30.56	22.06	58 lb	MB-15
PCI-35ABC	10.00	29.94	35.69	27.18	71 lb	MB-1
PCI-50sABC	10.00	29.94	35.69	27.18	86 lb	MB-1
PCI-70ABC	12.00	35.31	41.06	32.56	130 lb	MB-1
ALL DIMENSIONS IN INCHES						

Figure 2-1 Cylinder and Valve Assemblies

002841PC

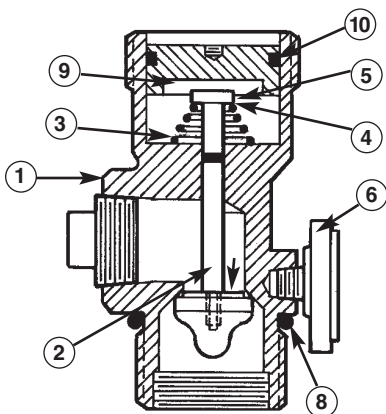

ITEM	PART NO.	DESCRIPTION
1	---	VALVE BODY
2	---	VALVE STEM & CAP ASSEMBLY
3	550022	CONICAL SPRING
4	550261	RETAINING WASHER
5	550024	E-RING
6	550025	PRESSURE GAUGE
7	550026	HIGH TEMPERATURE RELIEF PLUG
8	550029	VALVE BODY O-RING
9	550805	PISTON
10	550636	PISTON O-RING

Figure 2-2 Valve Cross Section

002842PC

NOZZLES

Nozzles have been developed for Open Face Paint Spray Booth protection. Each nozzle has been designed for use in certain areas of the booth. The Model N-SCR nozzle is used for screening the opening. The Model N-OTF nozzle is used for overhead total flooding application in the work area. The Model N-PLU nozzle is used for overhead application in the plenum area. The Model N-DCT nozzle is used for exhaust duct protection. The Model N-LA-ABC nozzle is used for local application in hazards where total flooding cannot be used. See **Figure 2-3**.

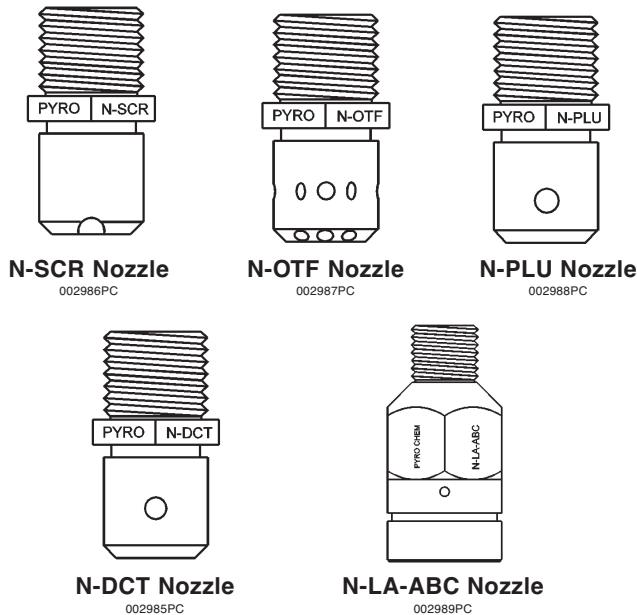

Figure 2-3 Nozzles,

CYLINDER BRACKETING

Vertical wall mounting for the **PCI-15ABC**, and **PCI-25sABC**, is provided by the Model **MB-15** mounting bracket kit. Vertical wall mounting for the **PCI-35ABC**, **PCI-50sABC** and **PCI-70ABC** is provided by the Model **MB-1** mounting bracket kit. See **Figure 2-4**.

- ▶ For vertical floor mounting of the **PCI-25sABC**, an 8 in. channel-type mounting bracket is available, the Model **MB-U8**.

For vertical floor mounting of the **PCI-35ABC** and **PCI-50sABC**, a 10 in. channel-type mounting bracket is available, the Model **MB-U10**.

- ▶ For vertical floor mounting of the **PCI-70ABC**, a 12 in. channel-type mounting bracket is available, the Model **MB-U12**.

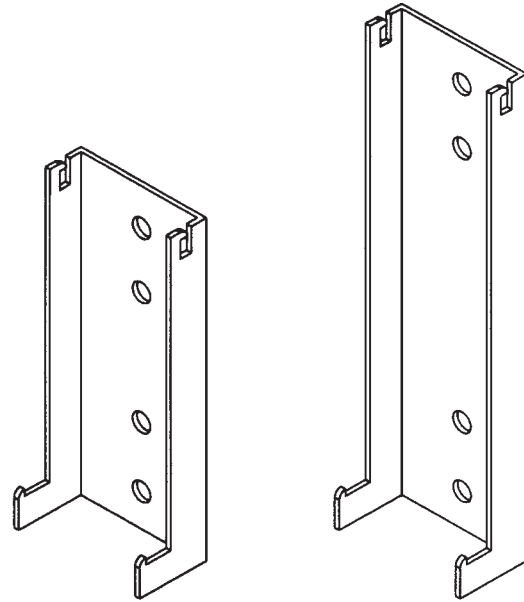

Figure 2-4 Mounting Brackets MB-15 and MB-1.

MODEL MCH3 – MECHANICAL CONTROL HEAD

The Model MCH3 mechanical control head is a fully mechanical control head which can be connected to the PCI-15/25s/35/50s/70 cylinder valve. This control head will support a fusible link detection system, a remote mechanical pull station (Model RPS-M), and a mechanical or electric gas shut-off valve. A micro switch (Model MS-SPDT, MS-DPDT, MS-3PDT, or MS-4PDT) can be ordered separately and field installed. It is equipped with a local manual control handle that allows for mechanical system actuation. Operation of the local manual control requires removing the pull pin and rotating the handle clockwise. The Model MCH3 control head can actuate a maximum of five (5) cylinders. See **Figure 2-5**.

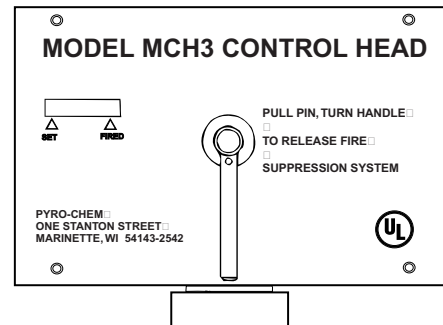

Figure 2-5. Mechanical Control Head.

004790PC

MODEL ECH3 – ELECTRIC CONTROL HEAD

The Model ECH3 electric control head is an electrically operated control head which can be connected to the PCI-15/25s/35/50s/70 cylinder valve. This control head will support an electric thermal detection system, a remote mechanical pull station (Model RPS-M), and an electric gas shut-off valve. It will not support a fusible link detection system. A micro switch (Model MS-DPDT) is included. The Model ECH3 control head is available in both 120 VAC (Model ECH3-120) and 24 VDC (Model ECH3-24). It is equipped with a local manual control handle that allows for mechanical system actuation. Operation of the local manual control requires removing the pull pin and rotating the handle clockwise. The Model ECH3 control head can actuate a maximum of five (5) cylinders with the 16 gram CO₂ cartridge. See **Figure 2-6**.

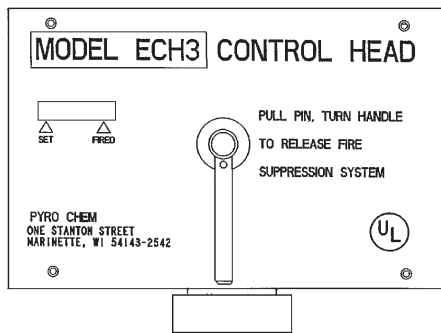

Figure 2-6. Electric Control Head.
 004789PC

MODEL NMCH3 – MECHANICAL CONTROL HEAD

The Model NMCH3 Mechanical Control Head is a fully mechanical control head which can be connected to the PCI-15/25s/35/50s/70 cylinder valve. This control head will support a fusible link detection system, a remote mechanical pull station (Model RPS-M), and a mechanical or electric shut-off valve. A micro switch (Model MS-SPDT, MS-DPDT, MS-3PDT, or MS-4PDT) can be ordered separately and field installed. There is no local manual actuation for the Model NMCH3. The Model NMCH3 control head can actuate a maximum of five (5) cylinders. See **Figure 2-6a**.

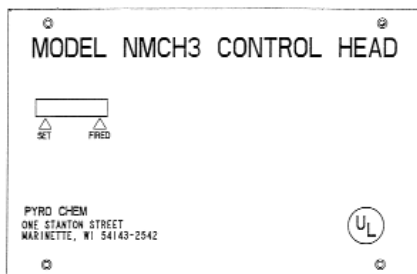

Figure 2-6a. Mechanical Control Head.
 006843PC

MODEL MB-P2 – CONTROL HEAD MOUNTING BRACKET

The Model MB-P2 mounting bracket must be used to mount the Model MCH3, NMCH3 or ECH3 control head if the control head is not mounted directly on a cylinder valve. See **Figure 2-7**.

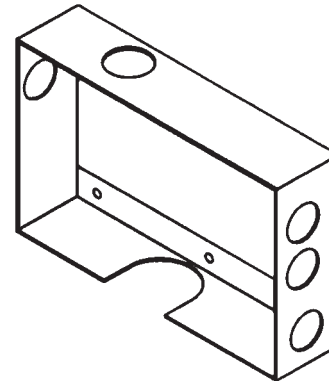

Figure 2-7. Model MB-P2 – Control Head Mounting Bracket.
 002846PC

CAUTION

Do not screw the control head directly to a wall as this will warp the control head, not allowing the mechanism to actuate.

MODEL PDA-D2 PNEUMATIC ACTUATING ADAPTOR

The Model PDA-D2 Pneumatic Actuating Adaptor is used to open the cylinder valve when the system is actuated. It must be installed on the valve of each cylinder unless a control head has been mounted on the cylinder valve. See **Figure 2-7a**.

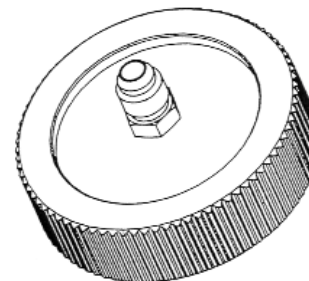

Figure 2-7a. Model PDA-D2 Pneumatic Actuating Adaptor.
 006886PC

PNEUMATIC ACTUATING CYLINDERS

1. Model PAC-10.

The Model PAC-10 is a pneumatic actuating cylinder that can actuate a maximum of ten (10) agent cylinders simultaneously. The Model PAC-10 includes a DOT 4BA350 cylinder pressurized with dry nitrogen to 350 PSIG @ 70° ., a brass valve with pressure gauge, and a wall mounting bracket. A Model MCH3, NMCH3 or ECH3 control head must be purchased separately and connected to the PAC-10 to open the valve. **See Figure 2-8.**

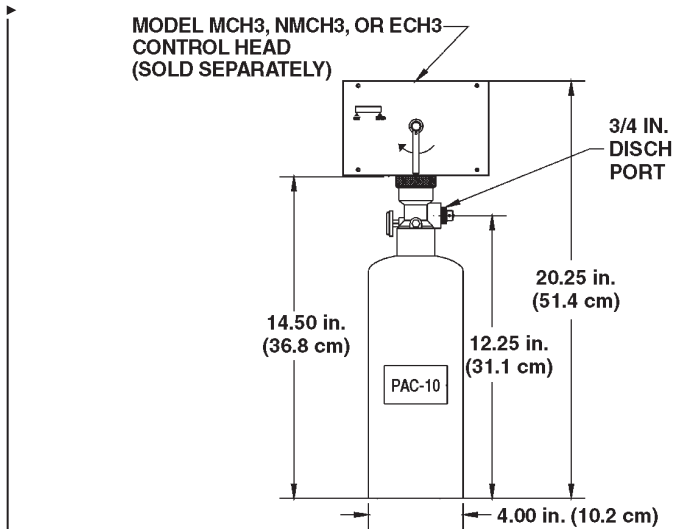

Figure 2-8. Model PAC-10 Pneumatic Actuating Cylinder.

002847PC

2. Model PAC-200.

The Model PAC-200 is a pneumatic actuating cylinder that can actuate a maximum of twenty (20) agent cylinders simultaneously. The Model PAC-200 includes a DOT 4BA350 cylinder pressurized with dry nitrogen to 350 PSIG @ 70° F, a brass valve with pressure gauge, and a wall mounting bracket. A Model MCH3, NMCH3 or ECH3 control head must be purchased separately and connected to the PAC-200 to open the valve. **See Figure 2-9.**

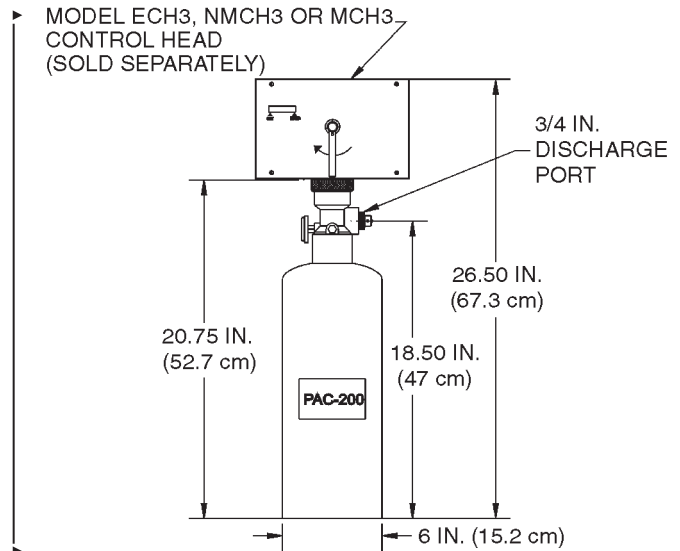

Figure 2-9. Model PAC-200 Pneumatic Actuating Cylinder.

002848PC

DETECTION EQUIPMENT

1. Model FLK-1.

- ▶ The Model FLK-1 fusible link kit includes a 10 in. steel
- ▶ bracket, two (2) 1/2 in. EMT connectors, two (2) cable
- ▶ crimps, and two (2) “S” hooks. Fusible links must be ordered
- ▶ separately. See Figure 2-10.

2. Model FLK-1A.

- ▶ The Model FLK-1A fusible link kit includes an 8 in. steel
- ▶ bracket, two (2) 1/2 in. EMT connectors, two (2) cable
- ▶ crimps, and two (2) “S” hooks. Fusible links must be ordered
- ▶ separately.

3. Model FLH-1.

The Model FLH-1 fusible link hanger is an accessory designed to simplify the installation of fusible links in the fusible link line. It can be used with the Model FLK-1/1A fusible link kits (kits must be ordered separately). The Fusible Link Hanger makes it possible to install fusible links without cutting and crimping loops in the fusible link line for each link. They are available in packages of 25 (FLH-25) only. See Figure 2-11.

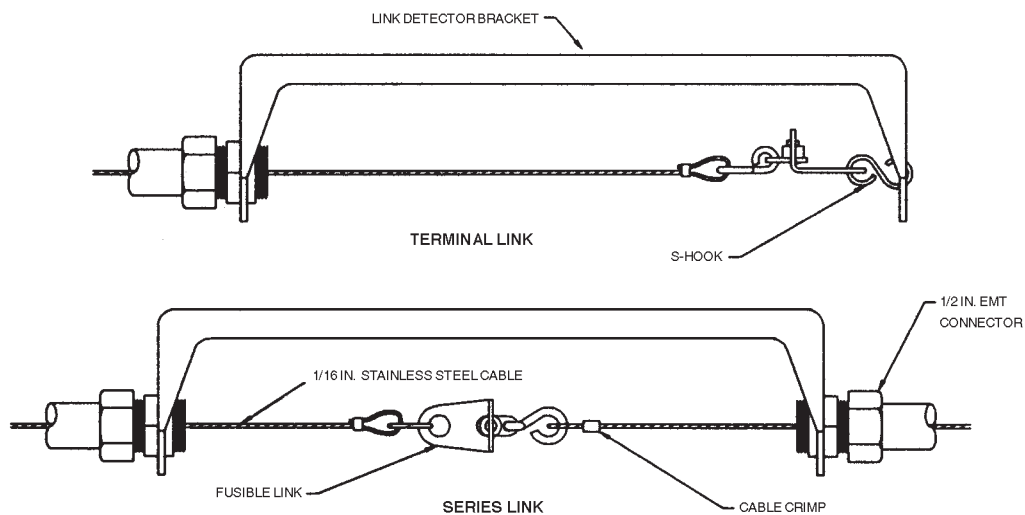

Figure 2-10. Model FLK-1 Fusible Link

002849PC

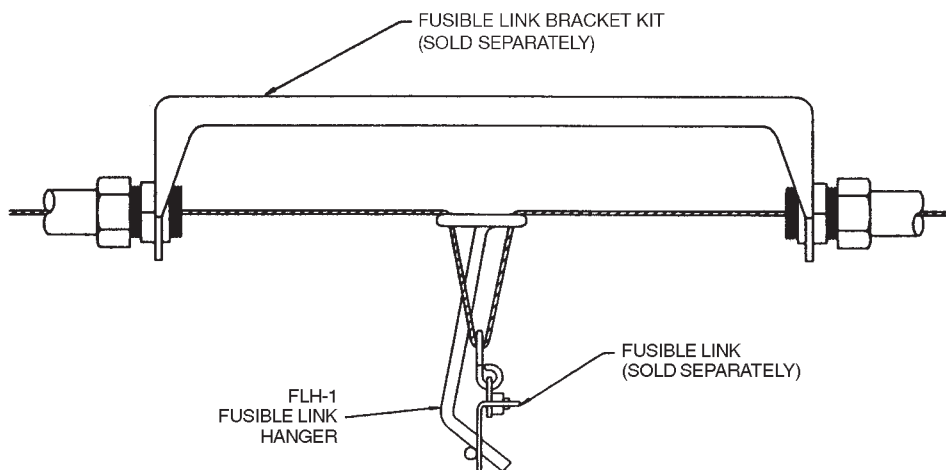

Figure 2-11. Model FLH-1 Fusible Link Hanger

002850PC

4. Fusible Links.

The fusible link is designed to separate at a specific temperature, releasing tension from the fusible link line, causing system actuation. See Figure 2-12.

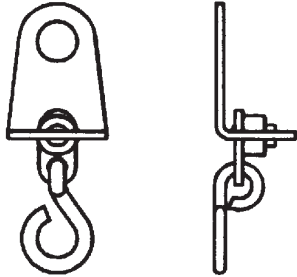

Figure 2-12. ML Style Fusible Link.
 002851PC

After determining the maximum ambient temperature at the fusible link location, select the correct fusible link according to the temperature condition chart below:

Fusible Link Model No.	Maximum Ambient Temperature
FL-165	100° F (38° C.)
FL-212	150° F (66° C.)
FL-280	225° F (107° C.)
FL-360	290° F (143° C.)
FL-450	360° F (182° C.)
FL-500	400° F (204° C.)

5. Thermal Detectors.

Rate compensated temperature thermal detectors are normally open, mechanical contact closure switches designed to operate at a factory preset temperature. They are available in six preset temperatures which meet NFPA standards and are UL Listed and FM Approved.

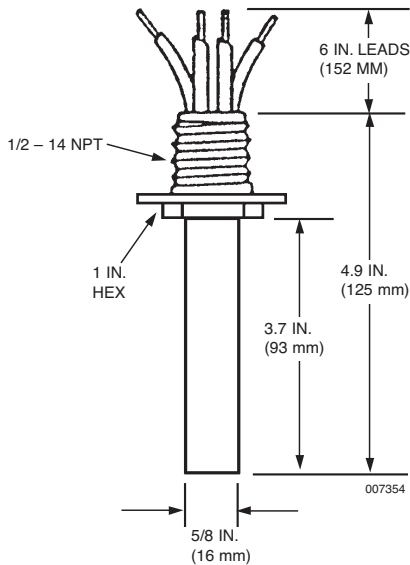

Figure 2-12a. Thermal Detector.
 007354

After determining the maximum ambient temperature at the thermal detector location, select the correct thermal detector according to the temperature condition chart below:

Thermal Detector Model No.	Maximum Ambient Temperature
TD-190	150° F (66° C.)
TD-225	185° F (85° C.)
TD-325	285° F (141° C.)
TD-450	410° F (210° C.)
TD-600	560° F (293° C.)

MODEL RPS-M – REMOTE MECHANICAL PULL STATION

Remote manual control for system releasing devices is provided by the Model RPS-M remote mechanical pull station. It is connected to the system releasing device by stainless steel cable. This cable is enclosed in 1/2 in. EMT conduit with corner pulleys at each change in direction. The remote mechanical pull station shall be located at the point of egress from the hazard area. See Figure 2-13.

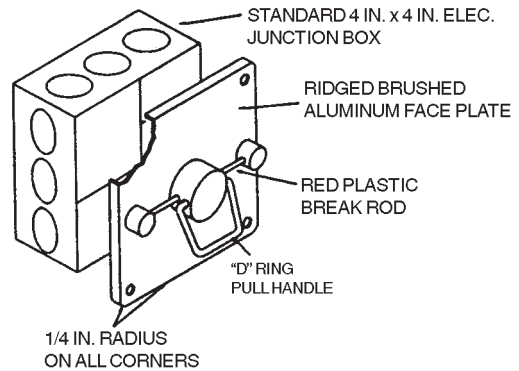
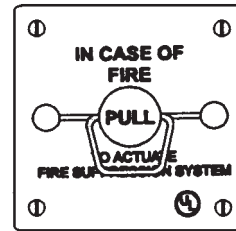
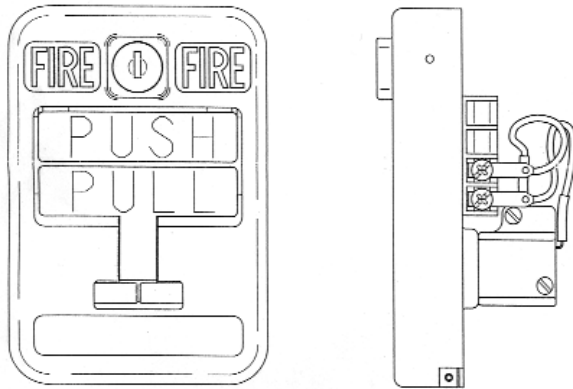

Figure 2-13. Model RPS-M Mechanical Pull Station.
 002852PC

MODEL RPS-E2

Remote manual actuation for the Model ECH3 control head is provided by the Model RPS-E2 remote electric pull station. Installation instructions are provided in the installation section of this manual. The remote electric pull station shall be located at the point of egress.



FRONT VIEW SIDE VIEW

Figure 2-13a. Model RPS-E2 Remote Electric Pull Station.

006887PC

GAS SHUT-OFF VALVES

1. Mechanical Gas Shut-off Valve.

A gas shut-off valve is required on all systems used to protect a gas fueled appliance to stop gas flow in the event of system actuation. A mechanical gas valve can be used with either the Model MCH3 or NMCH3 control head. It is connected to the system control head by stainless steel cable. This cable is enclosed in 1/2 in. EMT conduit with a corner pulley at each change in direction. The valves are rated for natural and LP gas (see Figure 2-14). Mechanical gas valves are available in the following sizes:

Model No.	Valve Size	Maximum Operating Pressure	Dim. "A"
GV-75	3/4 in.	5 psi	3/8 in.
GV-100	1 in.	5 psi	3/8 in.
GV-125	1-1/4 in.	5 psi	15/32 in.
GV-150	1-1/2 in.	5 psi	15/32 in.
GV-200	2 in.	5 psi	15/32 in.
GV-250	2-1/2 in.	5 psi	29/32 in.
GV-300	3 in.	5 psi	29/32 in.

*Note: "A" maximum is full open position of valve. Do not exceed. Distortion of internal parts can result.

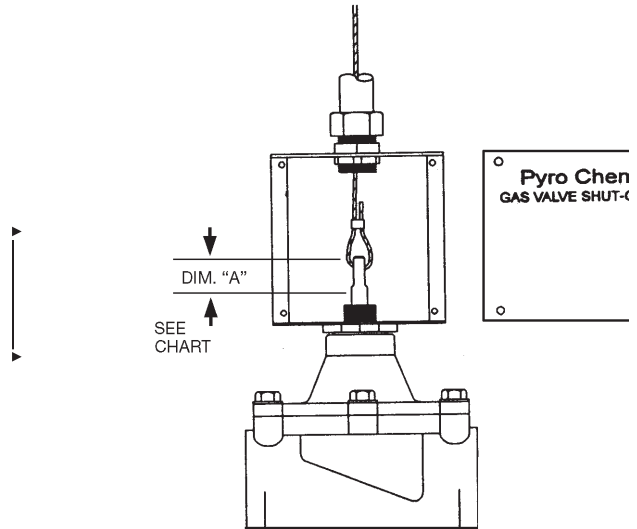

Figure 2-14. GV-Series Mechanical Gas Valve.

002853PC

2. Electric Gas Shut-off Valve.

A gas shut-off valve is required on all systems used to protect a gas fueled appliance to stop gas flow in the event of system actuation. A UL Listed electric gas valve can be used with either the Model MCH3, NMCH3 or ECH3 control head. The valves are rated for natural and LP gas. Valves are available in 120 VAC. Electric gas valves are available in the following sizes:

Model No.	Valve Size	Maximum Operating Pressure
EGVSO-75	3/4 in.	50 psi
EGVSO-100	1 in.	25 psi
EGVSO-125	1-1/4 in.	25 psi
EGVSO-150	1-1/2 in.	25 psi
EGVSO-200	2 in.	25 psi
EGVSO-250	2-1/2 in.	25 psi
EGVSO-300	3 in.	25 psi

Note: A UL Listed manual reset relay is required when using an electric gas valve. The PYRO-CHEM Model SM-120 solenoid monitor may be used for this purpose.

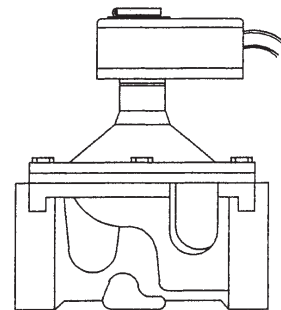

Figure 2-14a. Electric Gas Shut-off Valve.

006844PC

CORNER PULLEYS

1. Model SBP-1.

A corner pulley is used whenever a change in stainless steel cable direction is required. The Model SBP-1 corner pulley is equipped with a set screw fitting for connection to 1/2 in. EMT. See Figure 2-15.

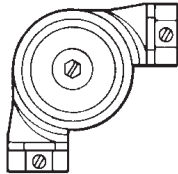

Figure 2-15. Model SBP-1 Corner Pulley.
 000160

2. Model CBP-1.

A corner pulley is used whenever a change in stainless cable direction is required. The Model CBP-1 is a grease-tight corner pulley designed for areas likely to experience excessive deposit build-up. It is equipped with a compression fitting for connection to 1/2 in. EMT. See Figure 2-16.

Note: The Model CBP-1 is not a liquid tight sealing device.

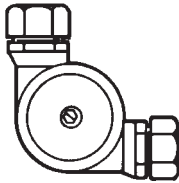

Figure 2-16. Model CBP-1 Corner Pulley.
 000161

3. Model WBP-1.

A corner pulley is used whenever a change in stainless cable direction is required. The Model WBP-1 is a liquid-tight corner pulley designed for areas likely to experience excessive moisture build-up. It is equipped with a female pipe thread for connection to 1/2 in. rigid conduit. See Figure 2-17.

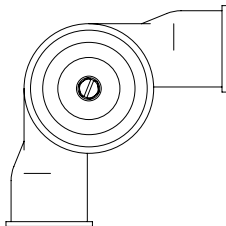

Figure 2-17. Model WBP-1 Corner Pulley.
 006194PC

TEE PULLEY

The Model TP-1 tee pulley is used to connect two mechanical gas valves or two remote mechanical pull stations to a single control head. The tee pulley replaces two standard 90° corner pulleys. See Figure 2-18.

CAUTION

The Tee Pulley must never be used to connect multiple fusible link lines to a single control head.

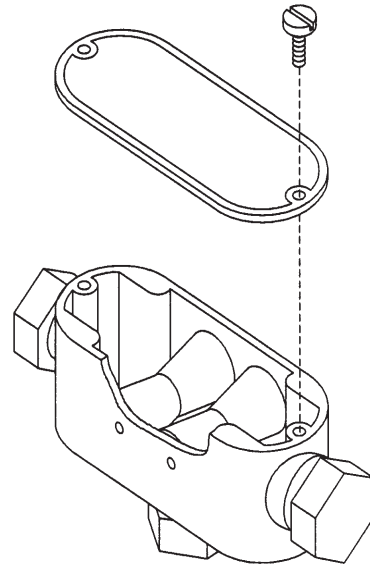

Figure 2-18. Model TP-1 Tee Pulley.
 002857PC

SWING CHECK VALVE

The Swing Check Valve, Part No. 417788, is required when piping a main and reserve Monarch tank on the same distribution piping. It allows the dry chemical agent to discharge through the agent piping leading to the discharge nozzles, while preventing it from flowing into the piping from the other tank. The swing check valve body is constructed of brass with a 1 in. NPT female thread. See Figure 2-19.

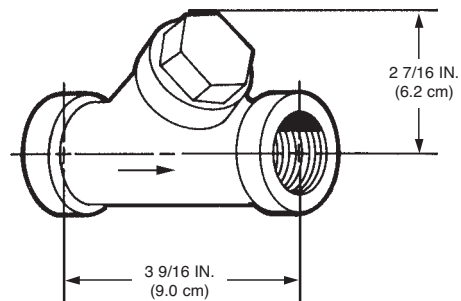

Figure 2-19. Swing Check Valve.
 000430

ELECTRICAL SWITCHES

The electrical switches are intended for use with electric gas valves, alarms, contactors, lights, contractor supplied electric power shut-off devices and other electrical devices that are designed to shut off or turn on when the system is actuated.

Switches are available in kits: One Switch Kit, Part No. 551154; Two Switch Kit, Part No. 551155; Three Switch Kit, Part No. 551156, and Four Switch Kit, Part No. 551157. Mounting hardware and 12 in. wire assemblies are provided with each kit. Each switch has a set of single-pole, double-throw contacts rated:

UL/cUL/CSA Rating
 250 VAC, 21A Resistive
 250 VAC, 2 HP
 125 VAC, 1 HP

ENEC Rating
 IE4T105 μ Approved
 250V, 21A Resistive
 8A Motor Load

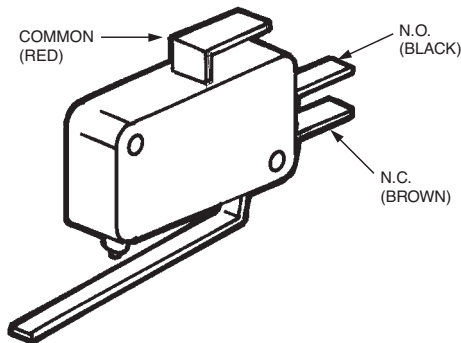

Figure 2-20a. Model MS-DPDT Micro Switch.

001612

The Alarm Initiating Switch Kit, Part No. 550077, can be field mounted within the control head. This switch must be used to close a supervised alarm circuit to the building main fire alarm panel when the control head actuates. This action will signal the fire alarm panel that there was a system actuation in the hazard area. The switch kit contains all necessary mounting components along with a mounting instruction sheet. The switch is rated 50 mA, 28 VDC.

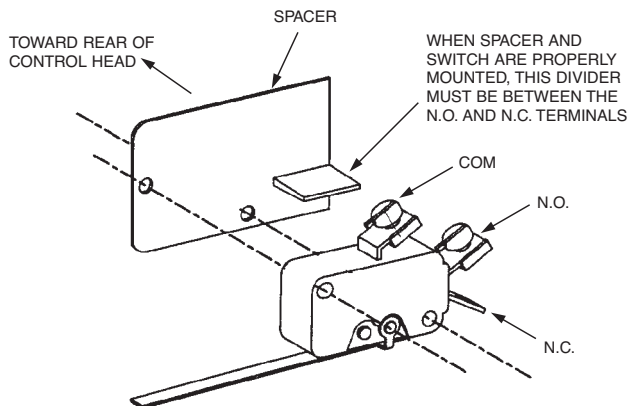

Figure 2-20b. Alarm Initiating Switch.

004890

See NFPA 72, "National Fire Alarm Code," Initiating Devices section, for the correct method of wiring connection to the fire alarm panel.

MODEL SM-120/24 SOLENOID MONITOR

The Model SM-120/24 solenoid monitor is used in conjunction with the Model ECH3 control head to supervise the actuation and detection circuits. In the event of a problem in the circuit, a light on the monitor goes out. The Model SM-120 is used with the Model ECH3-120 control head. The Model SM-24 is used with the Model ECH3-24 control head. Two sets of NO/NC dry contacts are provided. The unit mounts directly to a three gang wall outlet box. The Model SM-120 acts as a reset relay when used with an electric gas valve. Electric gas valve wiring instructions are provided in the installation section of this manual. See Figure 2-21.

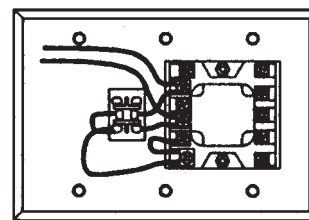
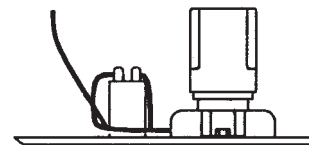
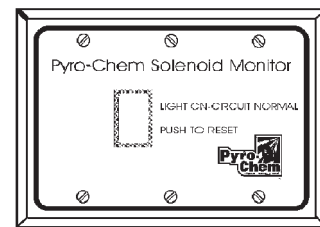

Figure 2-21. Model SM-24/120 Solenoid Monitor.

002860PC

STAINLESS STEEL ACTUATION HOSE

The Stainless Steel Actuation Hose is used to connect the actuation line compression tees and can also be connected end to end. The hose has the same thread, 7/16-20, as the fittings.

See Figure 2-22.

Hose Part No.	Length
417582	8 in. (20 cm)
31809	16 in. (41 cm)
32336	24 in. (61 cm)
430815	42 in. (107 cm)

Fitting

Part No.	Description
31810	Male Elbow (7/16-20 x 1/4 in. NPT)
31811	Male Tee (7/16-20 x 7/16-20 x 1/4 in. NPT)
32338	Male Straight Connector (7/16-20 x 1/4 in. NPT)



Figure 2-22. Stainless Steel Actuation Hose.

000433

PIPE & FITTINGS

Pipe and fittings must be furnished by the installer. Schedule 40 black, galvanized, chrome plated, or stainless steel pipe must be used. Standard weight malleable, galvanized, chrome plated, or stainless steel fittings must also be used.

PRESSURE SWITCHES

Model PS-SPDT-XP.

The Model PS-SPDT-XP is an explosion proof (NEMA 4; 7; 9) electrical pressure switch which can be field mounted in the discharge piping as shown in Figure 2-23. The switch is UL Listed (CCN: NOWT) and must be installed in accordance with the instructions contained with the switch and this manual. The switch provides one set of NO/NC dry contacts. It is intended for use with electric power shut-off devices (dealer supplied), electric gas valves, alarms, bells, lights, contactors, and other electrical devices designed to shut off or turn on upon system actuation. It is rated for 15 amps @ 125/250 VAC.

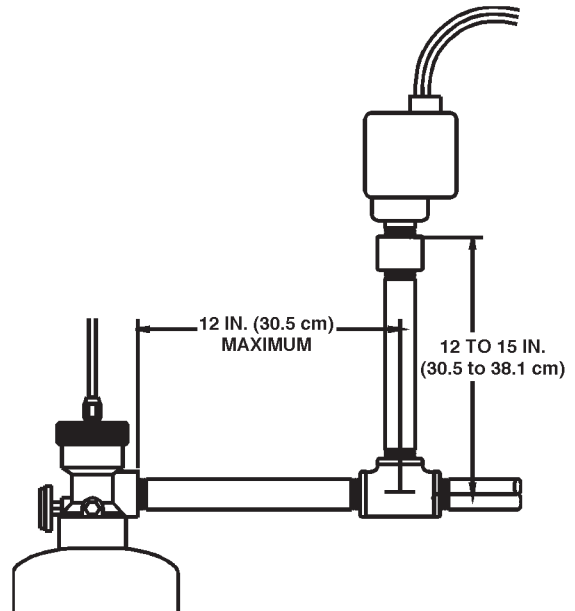

Figure 2-23. Pressure Switch Piping.

003025PC

PRESSURE BLEED DOWN ADAPTOR ASSEMBLY

The Pressure Bleed Down Adaptor Assembly, Part No. 551736, is required to open the valve stem on the tank when bleeding the tank down for six-year maintenance. See Figure 2-24.

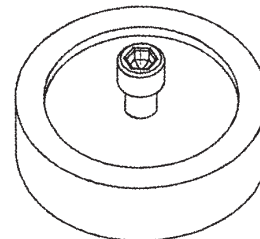

Figure 2-24. Pressure Bleed Down Adaptor Assembly.

004265

COMPONENT LIST
OPEN FACE PAINT SPRAY BOOTH SYSTEM

MODEL NO.	DESCRIPTION	PART NO.
PCI-15ABC	15 lb ABC Cylinder and Valve Assembly	550388
PCI-25sABC	25 lb ABC Cylinder and Valve Assembly	550390
PCI-35ABC	35 lb ABC Cylinder and Valve Assembly	551097
PCI-50sABC	50 lb ABC Cylinder and Valve Assembly	550392
PCI-70ABC	70 lb ABC Cylinder and Valve Assembly	551094
PAC-10	Pneumatic Actuating Cylinder	550104
PAC-200	Pneumatic Actuating Cylinder	550690
MB-P2	Control Head Mounting Bracket	550853
MB-15	Mounting Bracket (PCI-15,17,25s Cylinders)	550054
MB-1	Mounting Bracket (PCI-35,70 Cylinders)	550053
▶ MB-U8	8 in. Channel-Type Mounting Bracket	550324
MB-U10	10 in. Channel-Type Mounting Bracket	550383
▶ MB-U12	12 in. Channel-Type Mounting Bracket	550638
MCH3	Mechanical Control Head	551200
NMCH3	Mechanical Control Head	551203
ECH3-24	24VDC Electrical Control Head	551201
ECH3-120	120VDC Electrical Control Head	551202
- - -	8 in. S.S. Actuation Hose	417582
- - -	16 in. S.S. Actuation Hose	31809
- - -	24 in. S.S. Actuation Hose	32336
- - -	42 in. S.S. Actuation Hose	430815
- - -	Male Elbow	31810
- - -	Male Tee	31811
- - -	Male Straight Connector	32338
PDA-D2	Pneumatic Actuating Adaptor	550829
- - -	Swing Check Valve	417788
N-SCR	Nozzle Assembly	551098
N-OTF	Nozzle Assembly	551099
N-PLU	Nozzle Assembly	551100
N-LA-ABC	Nozzle Assembly	550646
N-DCT	Nozzle Assembly	551101
RPS-M	Remote Mechanical Pull Station	551074
RPS-E2	Remote Electric Pull Station	551166
FKL-1	10 in. Fusible Link Bracket	550131
FKL-1A	8 in. Fusible Link Bracket	550132
FLH-25	Fusible Link Hanger (25)	550876
FL-165	165° F Fusible Link	550368
FL-212	212° F Fusible Link	550365
FL-280	280° F Fusible Link	550366
FL-360	360° F Fusible Link	550009
FL-450	450° F Fusible Link	550367
FL-500	500° F Fusible Link	56816
SM-24	24VDC Solenoid Monitor	550303
SM-120	120VAC Solenoid Monitor	550302
▶ TD-190	190° F Thermal Detector	13970
TD-225	225° F Thermal Detector	13976
TD-325	325° F Thermal Detector	13975
TD-450	450° F Thermal Detector	13974
▶ TD-600	600° F Thermal Detector	13971
GV-75	3/4 in. Mechanical Gas Valve	550593
GV-100	1 in. Mechanical Gas Valve	550594
GV-125	1 1/4 in. Mechanical Gas Valve	550595
GV-150	1 1/2 in. Mechanical Gas Valve	550596

COMPONENT LIST
OPEN FACE PAINT SPRAY BOOTH SYSTEM (Continued)

MODEL NO.	DESCRIPTION	PART NO.
▶ GV-200	2 in. Mechanical Gas Valve	551049
GV-250	2 1/2 in. Mechanical Gas Valve	550185
GV-300	3 in. Mechanical Gas Valve	550186
EGVSO-75	3/4 in. Electric Gas Valve	550358
EGVSO-100	1 in. Electric Gas Valve	550359
EGVSO-125	1 1/4 in. Electric Gas Valve	550360
EGVSO-150	1 1/2 in. Electric Gas Valve	550361
EGVSO-200	2 in. Electric Gas Valve	550362
EGVSO-250	2 1/2 in. Electric Gas Valve	550363
▶ EGVSO-300	3 in. Electric Gas Valve	550385
MS-SPDT	Micro-Switch – Single Pole Double Throw	551154
MS-DPDT	Micro-Switch – Double Pole Double Throw	551155
MS-3PDT	Micro-Switch – 3 Pole Double Throw	551156
MS-4PDT	Micro-Switch – 4 Pole Double Throw	551157
▶ – – –	Alarm Initiating Switch	550077
PS-SPDT-XP	Pressure Switch – Single Pole Double Throw	550052
CO2-6	6 x CO ₂ Cartridge	551059
CBP-1	Compression Bearing Corner Pulley	423250
SBP-1	Screw Bearing Corner Pulley	415670
▶ WBP-1	Weather Proof Corner Pulley (10 Per Package)	550983
TP-1	Tee Pulley	550166
▶ WC-100	Oval Sleeve Crimps (100 Per Package)	550122
▶ – – –	Stop Sleeves (Pack of 10)	24919
– – –	Valve – Piston O-Ring	550636
– – –	Valve – Stem Washer	550284
– – –	Valve – Seat Washer	550021
– – –	Valve – Stem Head	550020
– – –	Valve – Body O-Ring	550029
– – –	Valve – Pressure Gauge	550025
– – –	Valve – Stem	550806
– – –	Valve – Stem O-Ring	550028
– – –	Valve – Conical Spring	550022
– – –	Valve – Piston	550805
▶ – – –	Pressure Bleed Down Adaptor Assembly	551736
– – –	Dry Valve Rebuilding Kit	550037
– – –	Recharge Adaptor	550130
▶ – – –	Dry Valve Hydrotest Adaptor	552182

CHAPTER III SYSTEM DESIGN

General

PYRO-CHEM Industrial Open Face Paint Spray Booth Fire Suppression System has been designed and tested for use in open face paint spray booth applications. The guidelines listed in this chapter deal with the limitations and parameters of various system configurations. It is the responsibility of the Certified installer to ensure that the proper system design is being utilized, and that the system meets the limitations and parameters listed in this chapter. Before attempting to design any system, it is necessary to attend a Factory Certification Training Class and become Certified to install PYRO-CHEM Industrial Open Face Paint Spray Booth Fire Suppression Systems.

Choosing the Proper Agent

It is necessary for the system designer to consider the combustible material found in the hazard area to ensure proper protection. The agent used in the system must be approved for the hazard class of the combustible material. The following are the hazard classes:

“A” Class – Ordinary solid carbonaceous combustibles. These include wood, paper, cloth, fiberglass, and plastics

“B” Class – Flammable liquids and gases. These include paints, solvents, gasoline, oils, and hydraulic fluids.

“C” Class – Electrical appliances. These include computers, power generators, and power transformers.

“D” Class – Combustible metals such as sodium, potassium, magnesium, titanium, and zirconium. The PYRO-CHEM Industrial Open Face Paint Booth Fire Suppression System is not intended to protect Class D hazards.

The following guidelines should be used for determining the proper agent:

ABC (monoammonium phosphate-based) – for use with all “A,” “B,” and “C” Class hazards.

As per NFPA 17, pre-engineered dry chemical systems are not approved for deep-seated or burrowing fires (such as ordinary combustibles where the agent cannot reach the point of combustion), or on chemicals that contain their own oxygen supply (such as cellulose nitrate). Do not mix different types of agents, or agents from different manufacturers. Chemical reactions may occur when incompatible chemicals are mixed. **Keep in mind that the agent must be acceptable to the Authority Having Jurisdiction.**

Choosing the Proper Type of System

It is necessary for the system designer to consider the physical characteristics and layout of the hazard area to ensure proper protection. The hazard area must meet the criteria for a particular system for that system to be effective. The hazard area must be protected in accordance with NFPA 17 for proper protection. The following guidelines are used to determine the proper system for a hazard:

Local Application – Overhead – This system is used for applying agent to an area from above the area. The maximum nozzle height for overhead protection is 10.5 feet for ABC coverage.

Total Flooding – This system is used to fill a volume with agent to protect any hazard within that volume. Total flooding systems require that an enclosure be present around the hazard area to allow the system to build up the proper concentration of agent within the hazard area.

The PYRO-CHEM Model N-SCR screening nozzle has been tested and approved by Underwriters Laboratories for unclosable openings. The nozzle will protect an area eight (8) feet wide at a height of twelve (12) feet.

- ▶ There is no limitation as to the percentage of unclosable opening.

The ventilation system must be shut down before or simultaneously with the discharge of the system.

Total Flooding

a. Cylinders:

The Models PCI-15ABC, PCI-25sABC, PCI-35ABC, PCI-50sABC, and PCI-70ABC cylinders can be used for open face paint spray booth applications.

b. Nozzles:

Four nozzles are available for use in protecting open face paint spray booths:

Nozzle	Application
N-SCR	Screening the opening
N-OTF	Work Area (Overhead Position)
N-PLU	Plenum Area (Overhead Position)
N-DCT	Duct

c. Temperature Range:

The operating temperature range for open face booth applications is 32 °F. to 120 °F. (0 °C. to 48 °C.).

d. Piping Requirements:

Piping diagrams include limitations on pipe length and fittings. See the following pages for specific piping design and limitations for each size cylinder.

Note: All listed piping diagrams represent maximum number of nozzles allowed. In applications that do not require the maximum number of nozzles, the quantity of nozzles can be reduced.

In applications of this type, along with the already listed limitations (notes included with each maximum layout), the following limitations apply:

- On the reduced nozzle side of the piping layout, the largest listed size pipe on the standard configuration layout must be utilized from T1 to nozzle.
- The maximum length of the reduced nozzle side must be the original combination from T1 to T2, and T2 to nozzle. **Note:** In systems utilizing a T3 split, the maximum length of the reduced nozzle side must be the original combination from T1 to T2, T2 to T3, and T3 to nozzle.
- The maximum number of elbows must be the original combination from T1 to T2, and T2 to nozzle. **Note:** In systems utilizing a T3 split, the maximum number of elbows must be the original combination from T1 to T2, T2 to T3, and T3 to nozzle.

e. Nozzle Placement:

The nozzle is to be mounted in the center (See Note) of the protected area, with the discharge holes in the nozzle no greater than six (6) inches from the ceiling. For duct protection, the nozzle is to be mounted in the center. See Figure 3-1.

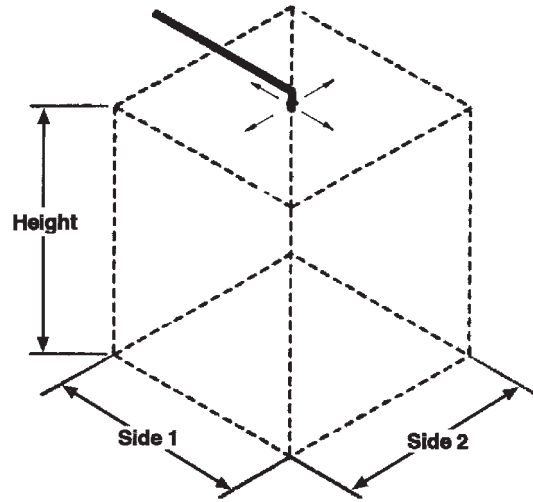

Figure 3-1. Nozzle Location

002866PC

Note: See Design Chart for allowable offset of nozzles from center of each hazard area.

f. Nozzle Coverages:

Protection	Nozzle	Protection Zone/Nozzle			Specifications Maximum	Nozzle Location within Protection Zone	Nozzle Offset**	Nozzle Orientation
		L	W	Ht				
Screening	N-SCR	—	8 ft (2.5 m)	12 ft (3.7 m)	Side 8 ft (2.4 m)	Length – Center Width – Center	0 – 6 in.	Vertical
Work Area	N-OTF	8 ft (2.4 m)	8 ft (2.4 m)	12 ft (3.7 m)	Area 64 sq ft (5.9 sq m) Side 8 ft (2.4 m)	Length – Center Width – Center	0 – 6 in.	Vertical
Plenum	N-PLU	4 ft (1.2 m)	8 ft (2.4 m)	12 ft (3.7 m)	Area 32 sq ft (3 sq m) Side 8 ft. (2.4 m)	Length – Center Width – Center	0 – 6 in.	Vertical
Exhaust Duct*	N-DCT	12 ft (3.7 m) Perimeter or 3 ft-10 in. (1.2 m) Dia. 24 ft (7.3 m) Length				Length – Center Width – Center	0 – 6 in.	Vertical for vertical ducts Horizontal for horizontal ducts

* Single nozzle application on a PCI-15ABC or two nozzle application on a PCI-25sABC only.

** Nozzle offset is the maximum distance from the tip of the nozzle and the closest edge of the protection zone.

PCI-15ABC with 1 nozzle
(Duct nozzle only)

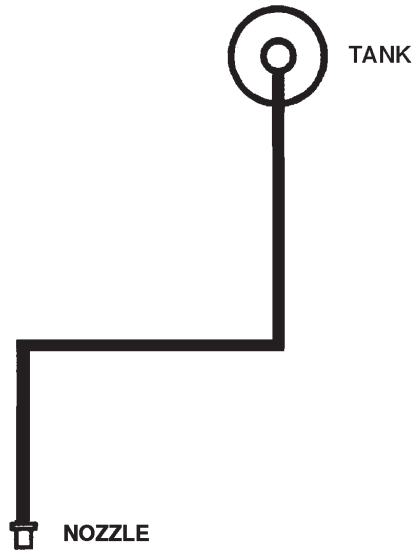

002868PC

Cylinder Size	Nozzle Quantity	Nozzle Type	Piping Section	Size	Length Maximum	Elbows Maximum	Maximum Nozzle Height From Base of Tank
▶ PCI-15ABC	1	N-DCT	Cylinder to Nozzle	3/4 in.	35 ft	6	16 ft 1 in.

NOTE:

- ▶ 1. These limitations apply to PCI-15ABC using one N-DCT nozzle.
- ▶ 2. A Main/Reserve Swing Check Valve, Part No. 417788, may be located between the cylinder and the nozzle.

PCI-25sABC with 2 Nozzles
 (Duct nozzles only)

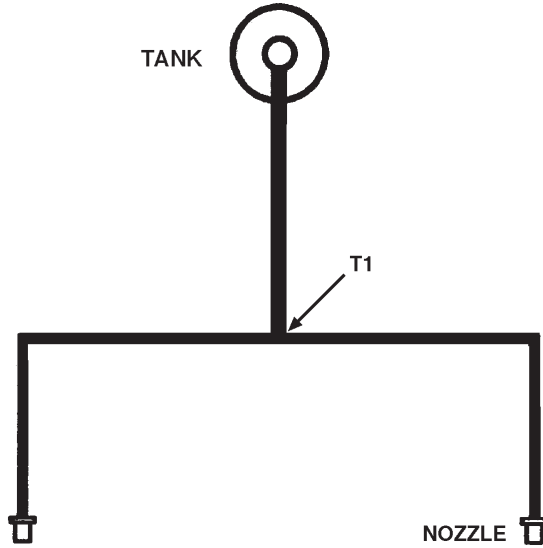

002863PC

Cylinder Size	Maximum Nozzle Quantity	Nozzle Type	Piping Section	Size	Length Maximum	Elbows Maximum	Maximum Nozzle Height From Base of Tank
PCI-25sABC	2	N-DCT	Cylinder to T1	3/4 in.	35 ft (10.7 m)	5	16 ft 1 in. (4.9 m)
			T1 to Nozzle	3/4 in.	15 ft (4.6 m)	3	16 ft 1 in. (4.9 m)

NOTE:

1. These limitations apply to PCI-25sABC using two N-DCT nozzles.
2. System piping must be balanced. Balanced piping is that in which the difference between the shortest actual pipe length from T1 to nozzle and the longest actual pipe length from T1 to nozzle does not exceed 10% of the longest actual pipe length from T1 to nozzle. The number and type of fittings for all last tee to nozzle sections must be equal.
3. A Main/Reserve Swing Check Valve, Part No. 417788, may be located between the cylinder and T1.

▶ On systems requiring duct and plenum protection, these areas can be protected utilizing a PCI-35ABC system with three nozzles.

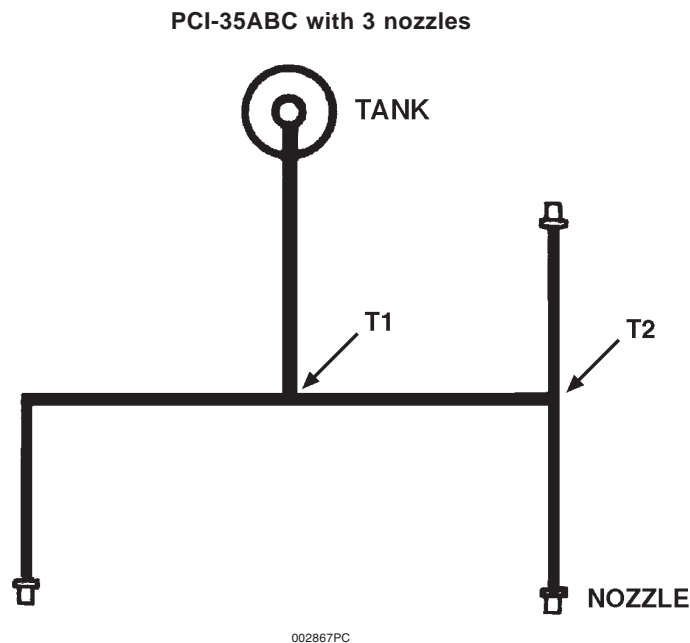

Cylinder Size	Maximum Nozzle Quantity	Nozzle Type	Piping Section	Size	Length Maximum	Elbows Maximum
PCI-35ABC	3	Two N-PLU One N-DCT	Cylinder to T1	3/4 in.	30 ft (9.1 m)	4
			T1 to T2	3/4 in.	12 ft (3.7 m)	2
			T2 to Nozzle	3/4 in.	8 ft (2.4 m)	2
			T1 to Nozzle	3/4 in.	12 ft (3.7 m)	2

NOTE:

1. These limitations apply to PCI-35ABC using three nozzles (2 N-PLU and 1 N-DCT).
2. For systems that have been tested with unbalanced piping, the difference in the length of piping must not exceed 10% of the maximum unbalanced ratio tested.
3. A Main/Reserve Swing Check Valve, Part No. 417788, may be located between the cylinder and T1.
4. Minimum requirements for piping and fittings do not apply to systems protecting hazards with no splashable hazard. A splashable hazard exists where liquid fuel in depth greater than 1/4 in. is present.
- ▶ 5. N-DCT nozzle must be located on T1 to nozzle branch.

► **NOTES:**

PCI-35ABC with 4 nozzles

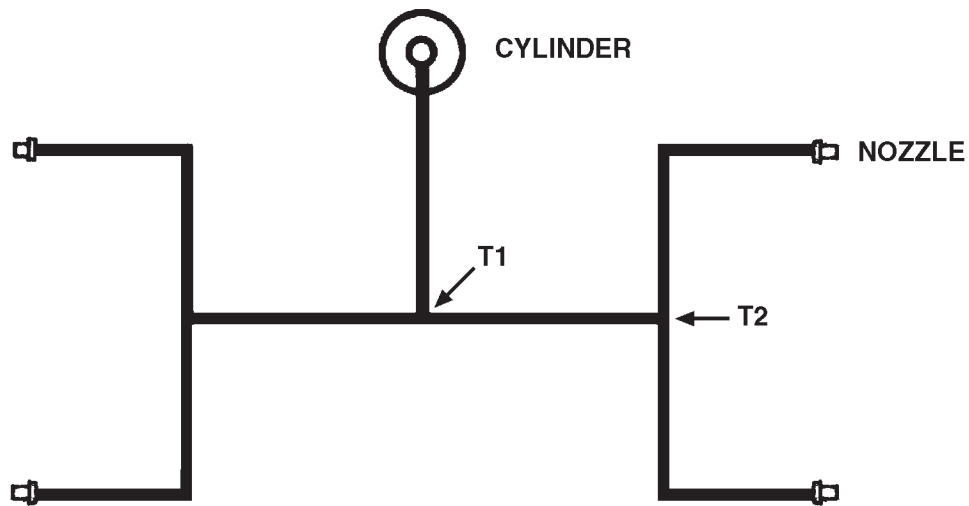

003020PC

Cylinder Size	Maximum Nozzle Quantity	Nozzle Type	Piping Section	Size	Length Maximum	Elbows Maximum	Maximum Nozzle Height From Base of Tank (N-DCT Nozzle Only)
PCI-35ABC	4	One N-SCR One N-PLU One N-OTF One N-DCT	Cylinder to T1	1 in.	18 ft (5.5 m)	3	16 ft 1 in. (4.9 m)
			T1 to T2	1 in.	10 ft (3.1 m)	1	
			T2 to N-SCR, N-OFT, N-PLU	3/4 in.	8 ft (2.4 m)	2	
			T2 to N-DCT	3/4 in.	9 ft (2.7 m)	3	

NOTE:

1. These limitations apply to PCI-35ABC using four nozzles (1 N-SCR, 1 N-PLU, 1 N-OTF, and 1 N-DCT).
2. System piping must be balanced. Balanced piping is that in which the difference between the shortest actual pipe length from T1 to nozzle and the longest actual pipe length from T1 to nozzle does not exceed 10% of the longest actual pipe length from T1 to nozzle. T2 to nozzle on the same branch must not exceed 10% of each other. The number and type of fittings for all last tee to nozzle sections must be equal.
3. A Main/Reserve Swing Check Valve, Part No. 417788, may be located between the cylinder and T1.

PCI-70ABC with 6 nozzles

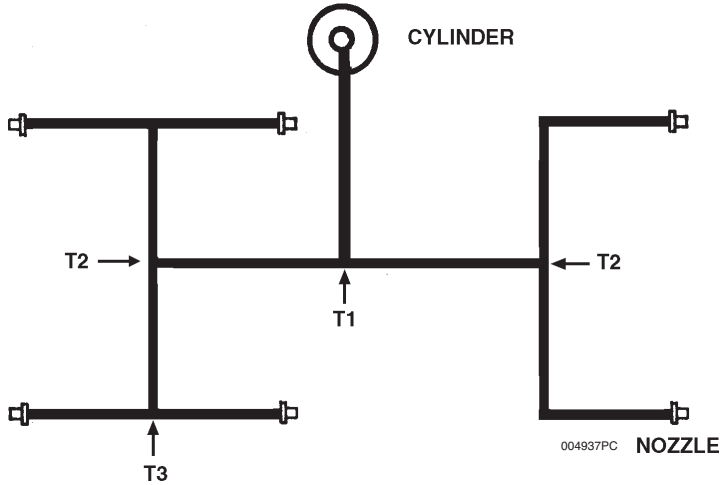

NOTE:

1. These limitations apply to PCI-70ABC using six nozzles (2-N-SCR, 4 N-OTF, or 6 N-OTF).
2. System piping must be balanced. Balanced piping is that in which the difference between the shortest actual pipe length from T1 to nozzle and the longest actual pipe length from T1 to nozzle does not exceed 10% of the longest actual pipe length from T1 to nozzle. T2 to nozzle on the same branch must not exceed 10% of each other. The number and type of fittings for all last tee to nozzle sections must be equal
3. A Main/Reserve Swing Check Valve, Part No. 417788, may be located between the cylinder and T1.
4. When using the 2-N-SCR, 4-N-OTF nozzle combination, the 2-N-SCRs must be located on the two nozzle side of the piping layout.

Cylinder Size	Maximum Nozzle Quantity	Nozzle Type	Piping Section	Size	Length Maximum	Elbows Maximum
PCI-70ABC	6	N-SCR, N-OTF	Cylinder to T1	1 in.	18 ft (5.5 m)	3
			T1 to T2 (4 Nozzle Side)	1 in.	14 ft (4.3 m)	1
			T2 to T3	3/4 in.	4 ft (1.2 m)	0
			T3 to Nozzle	3/4 in.	6 ft (1.8 m)	2
			T1 to T2 (2 Nozzle Side)	1 in.	14 ft (4.3 m)	2
			T2 to Nozzle	3/4 in.	6 ft (1.8 m)	2

PCI-70ABC with 8 nozzles

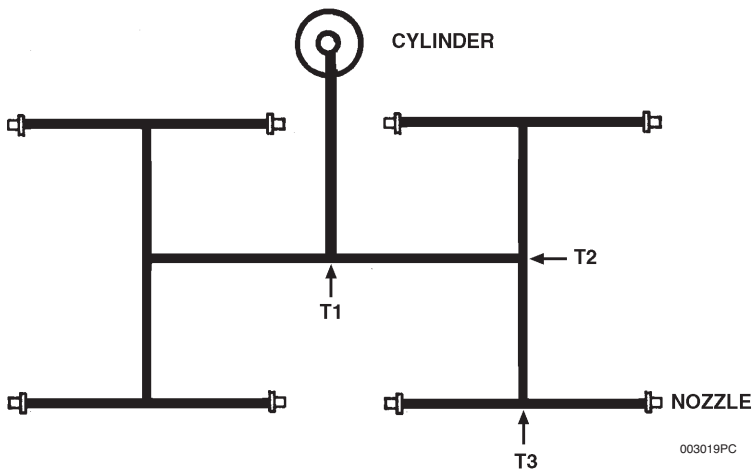

NOTE:

1. These limitations apply to PCI-70ABC using eight nozzles (2 N-SCR, 2 N-PLU, and 4 N-OTF).
2. System piping must be balanced. Balanced piping is that in which the difference between the shortest actual pipe length from T1 to nozzle and the longest actual pipe length from T1 to nozzle does not exceed 10% of the longest actual pipe length from T1 to nozzle. T2 to nozzle on the same branch must not exceed 10% of each other. The number and type of fittings for all last tee to nozzle sections must be equal
3. A Main/Reserve Swing Check Valve, Part No. 417788, may be located between the cylinder and T1.

Cylinder Size	Maximum Nozzle Quantity	Nozzle Type	Piping Section	Size	Length Maximum	Elbows Maximum
PCI-70ABC	8	Two N-SCR, Two N-PLU, and Four N-OTF	Cylinder to T1	1 in.	18 ft (5.5 m)	3
			T1 to T2	1 in.	10 ft (3.1 m)	1
			T2 to T3	3/4 in.	4 ft (1.2 m)	0
			T3 to Nozzle	3/4 in.	6 ft (1.8 m)	2

Local Application

- ▶ Local application consists of overhead application above the work area and protection of the duct and plenum utilizing the PCI-35ABC 3 nozzle system.

1. Local Application Overhead

a. Cylinders:

The Model PCI-25sABC and PCI-50sABC can be used for local overhead applications.

b. Nozzles:

- The Model N-LA-ABC nozzle is used for both the PCI-25sABC and PCI-50sABC systems. The maximum nozzle height of the Model N-LA-ABC nozzle is 10 ft (3 m). The minimum nozzle height of the Model N-LA-ABC nozzle is 7.5 ft (2.3 m).
- ▶

Note: Nozzle height is measured from the hazard surface to the closest point of the nozzle in the installed position.

c. Temperature Range:

The operating temperature range for the dry chemical cylinder assembly used for overhead applications is 32 °F to 120 °F (0 °C to 48 °C).

d. Piping Requirements:

Piping diagrams include limitations on pipe length and fittings.

e. Nozzle Placement and Coverage:

- The Model N-LA-ABC nozzle has been developed to provide local application of extinguishing agent from an overhead position. This nozzle will protect a hazard area of 25 sq ft (2.3 sq m) with a 5 ft (1.5 m) maximum side.
- ▶

PCI-25sABC with 2 Nozzles

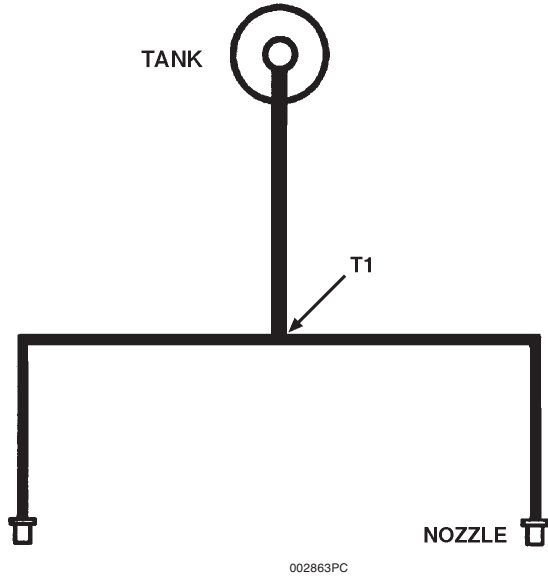

002863PC

Cylinder Size	Maximum Nozzle Quantity	Nozzle Type	Piping Section	Size	Length Maximum	Elbows Maximum	Length Minimum	Elbows Minimum
PCI-25sABC	2	N-LA-ABC	Cylinder to T1	3/4 in.	28 ft (8.5 m)	5	5 ft (1.5 m)	1
			T1 to Nozzle	3/4 in.	25 ft (7.6 m)	4	2.5 ft (.8 m)	1
			Total Cylinder to Nozzle		53 ft (16.2 m)	9	25 ft (7.8 m)	4

NOTE:

1. These limitations apply to PCI-25sABC using two N-LA-ABC nozzles.
2. System piping must be balanced. Balanced piping is that in which the difference between the shortest actual pipe length from T1 to nozzle and the longest actual pipe length from T1 to nozzle does not exceed 10% of the longest actual pipe length from T1 to nozzle. The number and type of fittings for all T1 to nozzle sections must be equal.
3. A Main/Reserve Swing Check Valve, Part No. 417788, may be located between the cylinder and T1.
4. Minimum requirements for piping and fittings do not apply to systems protecting hazards with no splashable hazard. A splashable hazard exists where liquid fuel in depth greater than 1/4 in. is present.

PCI-50sABC with 4 Nozzles

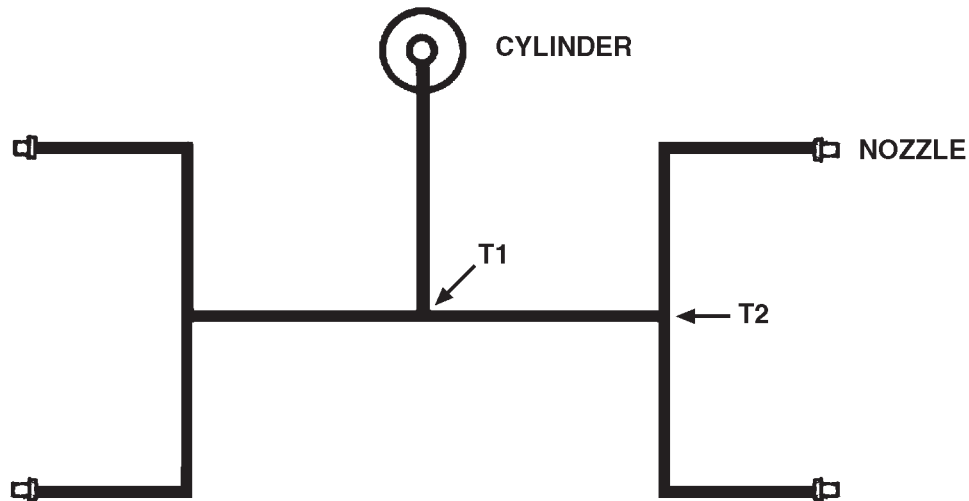

003020PC

Cylinder Size	Maximum Nozzle Quantity	Nozzle Type	Piping Section	Size	Length Maximum	Elbows Maximum	Length Minimum	Elbows Minimum
PCI-50sABC	4	N-LA-ABC	Cylinder to T1	1 in.	25 ft (7.6 m)	4	5 ft (1.5 m)	1
			T1 to T2	3/4 in.	10 ft (3.1 m)	2	2.5 ft (0.8 m)	0
			T2 to Nozzle	3/4 in.	8 ft (2.4 m)	2	2.5 ft (0.8 m)	1
			Total Cylinder to Nozzle		43 ft (13.1 m)	8	20 ft (6.1 m)	3

NOTE:

1. These limitations apply to PCI-50sABC using four N-LA-ABC nozzles.
2. System piping must be balanced. Balanced piping is that in which the difference between the shortest actual pipe length from T1 to nozzle and the longest actual pipe length from T1 to nozzle does not exceed 10% of the longest actual pipe length from T1 to nozzle. T2 to nozzle on the same branch must not exceed 10% of each other. The number and type of fittings for all last tee to nozzle sections must be equal
3. A Main/Reserve Swing Check Valve, Part No. 417788, may be located between the cylinder and T1.
4. Minimum requirements for piping and fittings do not apply to systems protecting hazards with no splashable hazard. A splashable hazard exists where liquid fuel in depth greater than 1/4 in. is present.

2. Protecting Duct and Plenum on Local Application Systems

On systems requiring local application protection in the work area, the duct and plenum can be protected utilizing a PCI-35ABC system with three nozzles.

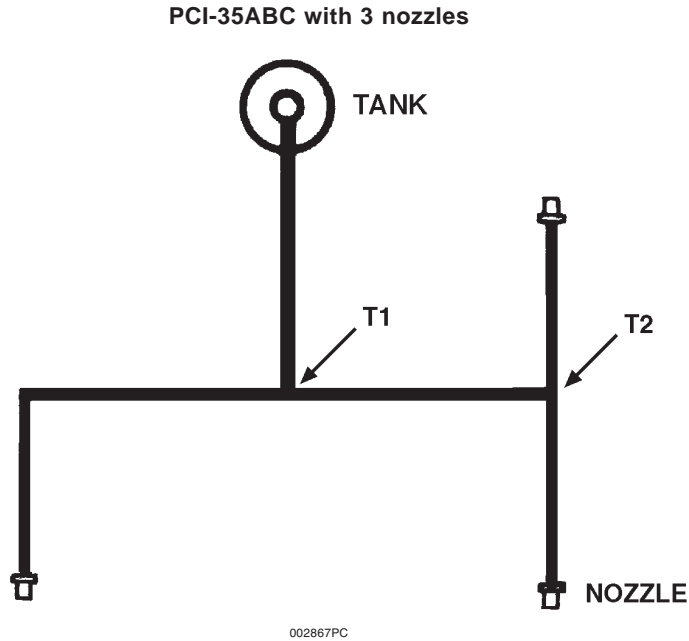

Cylinder Size	Maximum Nozzle Quantity	Nozzle Type	Piping Section	Size	Length Maximum	Elbows Maximum
PCI-35ABC	3	Two N-PLU One N-DCT	Cylinder to T1	3/4 in.	30 ft (9.1 m)	4
			T1 to T2	3/4 in.	12 ft (3.7 m)	2
			T2 to Nozzle	3/4 in.	8 ft (2.4 m)	2
			T1 to Nozzle	3/4 in.	12 ft (3.7 m)	2

NOTE:

1. These limitations apply to PCI-35ABC using three nozzles (2 N-PLU and 1 N-DCT).
2. For systems that have been tested with unbalanced piping, the difference in the length of piping must not exceed 10% of the maximum unbalanced ratio tested.
3. A Main/Reserve Swing Check Valve, Part No. 417788, may be located between the cylinder and T1.
4. Minimum requirements for piping and fittings do not apply to systems protecting hazards with no splashable hazard. A splashable hazard exists where liquid fuel in depth greater than 1/4 in. is present.
5. N-DCT nozzle must be located on T1 to nozzle branch.

Detector Placement

Thermal detectors are required in all hazard areas protected by the PYRO-CHEM Open Face Paint Spray Booth Industrial Fire Suppression System if automatic system operation is required. Either mechanical or electrical thermal detectors can be used for automatic system operation. Mechanical detectors (fusible links) are used in conjunction with the PYRO-CHEM Models MCH3 and NMCH3 control devices. Electrical detectors are used in conjunction with the PYRO-CHEM Models ECH3-24 and ECH3-120 Control Heads.

TOTAL FLOODING (DETECTOR SPACING) – THERMAL

Ceiling Height	Spacing
Up to 14 ft (4.2 m) Height	15 ft (4.5 m) maximum between detectors 7 ft 6 in. (2.3 m) max. from wall 225 sq ft (20.9 sq m) max. coverage per detector
Greater than 14 ft (4.2 m) up to 20 ft (6.1 m) height	13 ft (3.9 m) maximum between detectors 6 ft 6 in. (1.9 m) max. from wall 169 sq ft (15.7 sq m) max. coverage per detector
Greater than 20 ft (6.9 m) up to 24 ft (7.3 m)	11 ft (3.4 m) max. between detectors 5 ft 6 in. (1.7 m) max. from wall 121 sq ft (11.2 sq m) max. coverage per detector
Greater than 24 ft (7.3 m) up to 30 ft (9.1 m)	9 ft (2.7 m) max. between detectors 4 ft 6 in. (1.4 m) max. from wall 81 sq ft (7.5 sq m) max. coverage per detector

Note: For sloped ceiling (peaked type or shed type) installations, refer to NFPA-72, "National Fire Alarm Code" for detailed spacing requirements.

LOCAL APPLICATION – OVERHEAD (DETECTOR SPACING) – Maximum spacing per detector is 100 ft² (9.3 m²) or 5 ft (1.5 m) from edge of hazard and 10 ft (3.1 m) between detectors. When detectors are mounted below the ceiling in an open area, heat traps are recommended.

LOCAL APPLICATION – TANKSIDE (DETECTOR SPACING) – Detectors can be located either near the inner tank wall and flammable liquid surface or above the tank. If located above the tank, the rules for local application overhead would apply. If located on the tank wall, the detectors can be mounted horizontally or vertically in the freeboard area, but must be protected from damage during normal working operations. The maximum spacing per detector is 5 ft (1.5 m) from edge of hazard and 10 ft (3.1 m) between detectors.

A temperature survey must be performed to determine the maximum ambient temperature of the hazard survey. See Temperature Chart in Chapter 2 – Components.

TOTAL FLOODING (DETECTOR SPACING) – FUSIBLE LINKS

Ceiling Height	Spacing
Up to 12 ft (3.66 m) Height	12 ft (3.66 m) maximum detectors 6 ft (1.83 m) max. from a wall* 144 sq ft (13.38 sq m) max. coverage per detector
Greater than 12 ft (3.66 m) up to 16 ft (4.88 m) height	10 ft (3.05 m) max. between detectors 5 ft (1.52 m) max. from wall 100 sq ft (9.29 sq m) max. coverage per detector
Greater than 16 ft (4.88 m) up to 20 ft (6.1 m) height	8 ft (2.44 m) max. between detectors 4 ft (1.22 m) max. from wall 64 sq ft (5.95 sq m) max. coverage per detector

Note: For sloped ceiling (peaked type or shed type) installations, refer to NFPA-72, "National Fire Alarm Code" for detailed spacing requirements.

LOCAL APPLICATION – OVERHEAD (DETECTOR SPACING) – Maximum spacing per fusible link detector is 36 ft² (3.3 m²) or 3 ft (0.9 m) from edge of hazard and 6 ft (1.8 m) between fusible link detectors.

When a detector(s) is mounted more than 1 ft (0.3 m) below ceiling or in an open area, heat trap(s) is recommended. Detectors should be mounted overhead at nozzle height or as close to the hazard as possible without interference, not to exceed 10 ft (3 m).

Detectors should not be located where they will be susceptible to damage during the normal work operation.

LOCAL APPLICATION – TANKSIDE (DETECTOR SPACING) – Detectors can be located either near the inner tank wall and flammable liquid surface or above the tank. If located above the tank, the rules for local application overhead would apply. If located on the tank wall, the detectors can be mounted horizontally or vertically in the freeboard area but must be protected from damage during normal working operation. Detectors should be located at a maximum spacing per detector of 3 ft (0.9 m) from edge of hazard and 6 ft (1.8 m) between detectors on the long side of the tank.

*For 14 ft (4.3 m) wide booths with maximum height of 12 ft (3.7 m), the detector location off the side wall can be a maximum of 7 ft (2.1 m), and 10 ft (3 m) maximum distance between detectors.

NOTES:

CHAPTER IV SYSTEM INSTALLATION

This chapter will detail the basic information necessary for proper installation of the PYRO-CHEM Open Face Paint Spray Booth Industrial Fire Suppression System. However, before attempting any installation it is necessary to attend a Factory Certification Training Class and become Certified to install the PYRO-CHEM Industrial Open Face Paint Spray Booth Fire Suppression System.

Pipe and fittings for the discharge piping, conduit (EMT), pipe straps, pipe hangers, mounting bolts, and other miscellaneous equipment are not furnished as part of the PYRO-CHEM Open Face Paint Spray Booth Industrial Fire Suppression System. These items must be furnished by the installer.

Before attempting any installation, unpack the entire system and check that all necessary parts are on hand. Inspect parts for damage. Verify that cylinder pressure is within the acceptable range as shown on the gauge.

CYLINDER INSTALLATION

The cylinder and valve assembly is shipped with an anti-recoil plug in the valve discharge port.

CAUTION

The anti-recoil plug must remain in the valve discharge port until the discharge piping is connected to the valve.

The cylinder must be mounted vertically with the discharge port facing either left or right. The Models PCI-15ABC, PCI-17ABC, and PCI-25sABC cylinders must be mounted using a Model MB-15 Mounting Bracket Kit. The Model PCI-35ABC, PCI-50sABC, and PCI-70ABC cylinders must be mounted using a Model MB-1 Mounting Bracket Kit.

The bracket must be securely anchored to the wall using bolts or lag screws. The wall to which the bracket is attached must be sufficiently strong to support the cylinder. The bracket should never be fastened to dry wall or similar material. If this type of wall is encountered, studs must be located and the bracket fastened to them. **See Figure 4-1.**

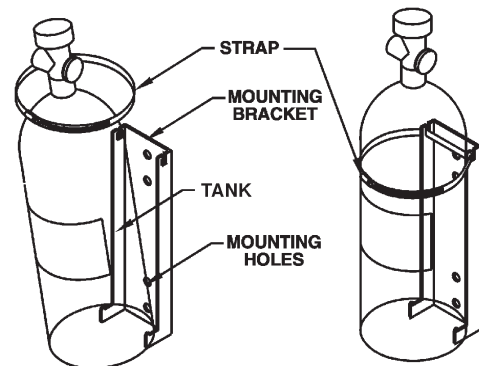

Figure 4-1. Cylinder and Mounting Bracket Installation.

002871PC

CONTROL HEAD INSTALLATION

1. Single Cylinder Installations.

For single cylinder system installations the Model MCH3/ECH3/NMCH3 Control Head can be installed directly onto the cylinder valve. When the control head is properly aligned in the desired position, tighten the knurled locking ring to secure the assembly. **See Figure 4-2.**

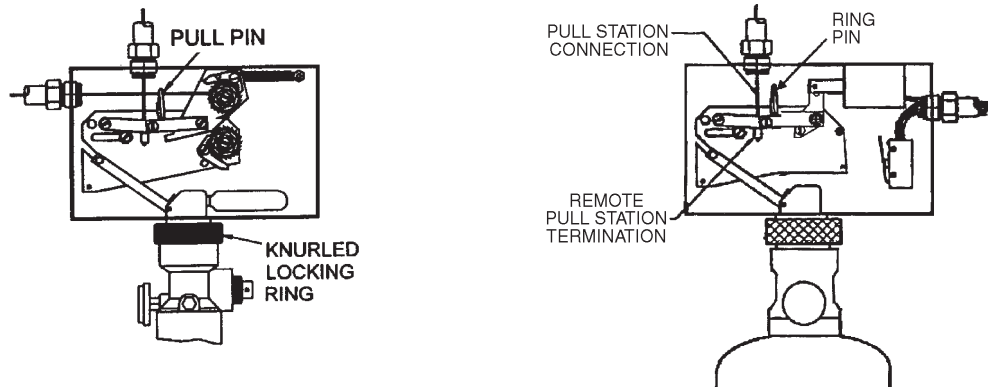

Figure 4-2. Single Cylinder Installation Using Model MCH3/ECH3/NMCH3 Control Head

002872PC/003647PC

2. Multiple Cylinder Installations.

A. Multiple Cylinder Actuation Using MCH3/ECH3/NMCH3 Control Head.

The Model MCH3/ECH3/NMCH3 Control Head can be used to pneumatically actuate a maximum of five (5) agent cylinders with a 16 gram CO₂ cartridge. When a control head is used for multiple cylinder actuation, it cannot be mounted directly onto a cylinder valve. The control head must be installed remotely using a Model MB-P2 Control Head Mounting Bracket. The bracket must be anchored to the wall using bolts or lag screws.

CAUTION

Do not screw the control head directly to a wall as this will warp the control head, not allowing the mechanism to actuate.

In order to actuate the agent cylinder(s) from a control head, a 1/4 in. NPT x 45° 1/4 in. flare type fitting (conforming to SAE J513c) or male straight connector (Part No. 32338) must be screwed into the base of the control head actuator. Also, a Model PDA-D2 Pneumatic Discharge Adaptor must be installed on the valve of each agent cylinder. Pneumatic tubing or stainless steel actuation hose is then used to connect the control head to the PDA-D2 of each agent cylinder valve. See Figure 4-3.

NOTE

Pneumatic tubing used for remote cylinder actuation shall have an outside diameter of 1/4 in. with a minimum wall thickness of 1/32 in. This is commonly known as refrigeration-type copper tubing. All tubing fittings shall be of the 1/4 in., 45° flare type conforming to SAE J513c. **Compression type fittings are not acceptable.**

A single Model MCH3/ECH3/NMCH3 Control Head can actuate:

1. Up to four (4) cylinders with a maximum of 25 ft (7.6 m) of copper or stainless steel pneumatic tubing or stainless steel actuation hose when using an O-ring (Part No. 55531) installed in place of the Teflon washer and the 16 gram CO₂ cartridge.
2. Up to five (5) cylinders with a maximum of 18 ft (5.4 m) of copper or stainless steel pneumatic tubing or stainless steel actuation hose when using an O-ring (Part No. 55531) installed in place of the Teflon washer and the 16 gram CO₂ cartridge.

CAUTION

Confirm the Teflon washer in the control head actuator assembly has been replaced with the O-ring (Part No. 55531) and the 16 gram CO₂ cartridge is installed for 4 and 5 cylinder single control head actuation.

The actuation line must be tested for any leaks by using a hand held or electric vacuum pump. The pump should be used to draw a vacuum on the actuation line at the fitting closest to the control head. A vacuum should be pulled to 20 inches of mercury. Leaks exceeding 5 inches of mercury within 30 seconds are not allowed. If the gauge on the vacuum pump indicates a leak in the line, examine the actuation line for loose fittings or damage. Correct any leaks and retest.

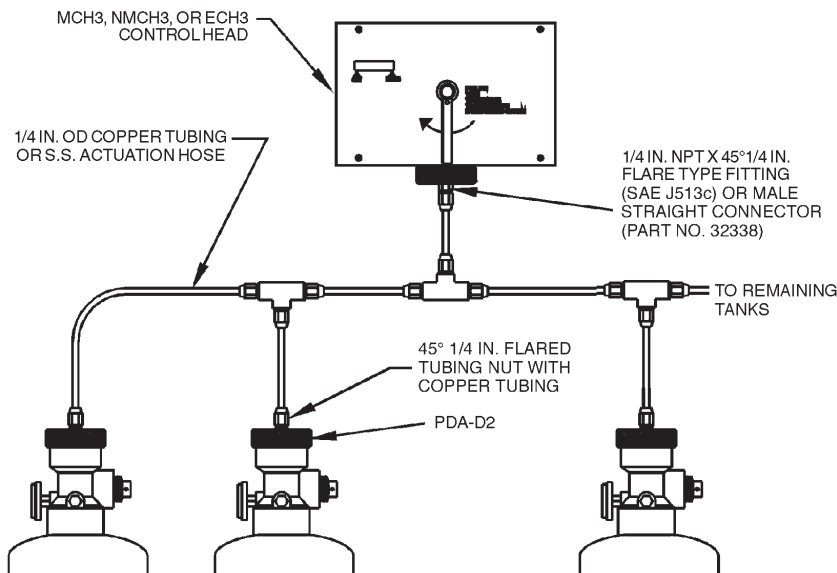

Figure 4-3. Multiple Cylinder Actuation Using Model MCH3/ECH3/NMCH3 Control Head.

002873PC

B. Multiple Cylinder Actuation Using Model PAC-10 or PAC-200 Pneumatic Actuation Cylinder.

The Model PAC-10 or PAC-200 Pneumatic Actuation

- ▶ Cylinder must be used if more than five (5) agent cylinders require simultaneous actuation. The Model PAC-10/200 must be used in conjunction with a Model MCH3/ECH3/NMCH3 Control Head. The control head is mounted on the Model PAC-10/200 valve assembly.

The Model PAC-10/200 is shipped complete with a mounting bracket. The cylinder must be mounted vertically with the nameplate facing out. The bracket must be securely anchored to the wall using bolts or lag screws. The wall to which the bracket is attached must be sufficiently strong to support the pneumatic cylinder. The bracket should never be fastened to dry wall or similar material. If this type of wall is encountered, studs must be located and the bracket fastened to them. See **Figure 4-4**.

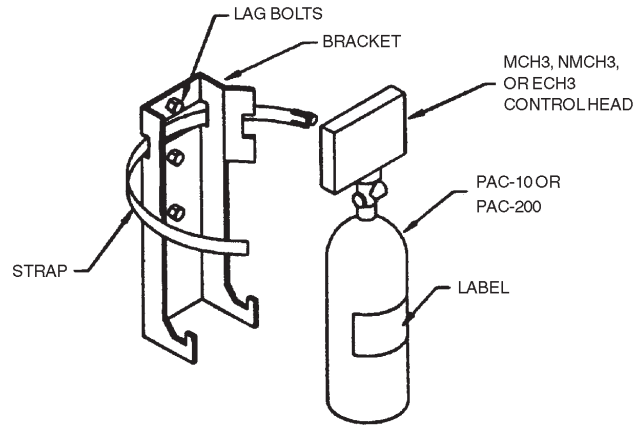

Figure 4-4. Model PAC-10/200 Pneumatic Cylinder Installation.

002874PC

- ▶ In order to actuate the agent cylinders from a Model PAC-10/200 Pneumatic Actuation Cylinder, a 3/4 in. NPT x 1/4 in. NPT bushing must be screwed into the pneumatic cylinder's discharge port. A 1/4 in. NPT x 45° 1/4 in. flare type fitting (conforming to SAE J513c) must then be screwed into this bushing. The male straight connector (Part No. 32338) is used with stainless steel actuation hose. Also, a Model PDA-D2 Pneumatic Discharge Adaptor must be installed on the valve of each agent cylinder. Pneumatic or stainless steel tubing is then used to connect the PAC-10/200 pneumatic cylinder to the PDA-D2 of each agent cylinder valve. See **Figure 4-5**.

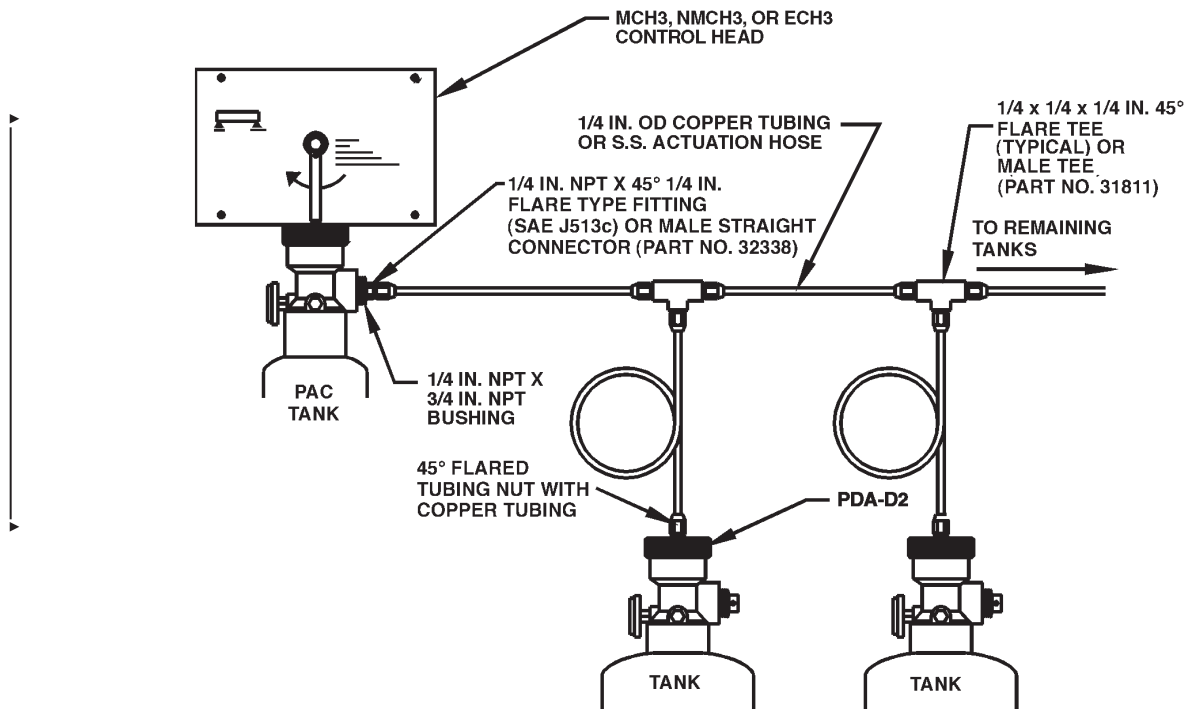

Figure 4-5. Multiple Cylinder Actuation Using Model PAC-10 or PAC-200.

002875PC

NOTE

- ▶ Pneumatic tubing used for remote cylinder actuation shall have an outside diameter of 1/4 in. with a minimum wall thickness of 1/32 in. This is commonly known as refrigeration-type copper tubing. All tubing fittings shall be of the 1/4 in., 45° flare type conforming to SAE J513c. **Compression type fittings are not acceptable.**

The Model PAC-10 pneumatic cylinder can actuate a maximum of ten (10) agent cylinders with a maximum of 100 ft (30.5 m) of pneumatic tubing.

The Model PAC-200 pneumatic cylinder can actuate a maximum of twenty (20) agent cylinders with a maximum of 200 ft (61 m) of pneumatic tubing.

▶ C. Multiple Cylinder Actuation Using Two Control Heads.

If the system design requires the use of two control heads for multiple cylinder actuation, a maximum of 25 ft (7.6 m) of tubing or stainless steel actuation hose is allowed between the two control heads and the PAC-10 cylinder. See **Figure 4-5a**. If a PAC-10 cylinder is not utilized, there is a maximum of 25 ft (7.6 m) of tubing or stainless steel actuation hose for the two control heads and up to 4 cylinders or a maximum of 18 ft (5.4 m) of tubing or stainless steel actuation hose for the two control heads and 5 cylinders.

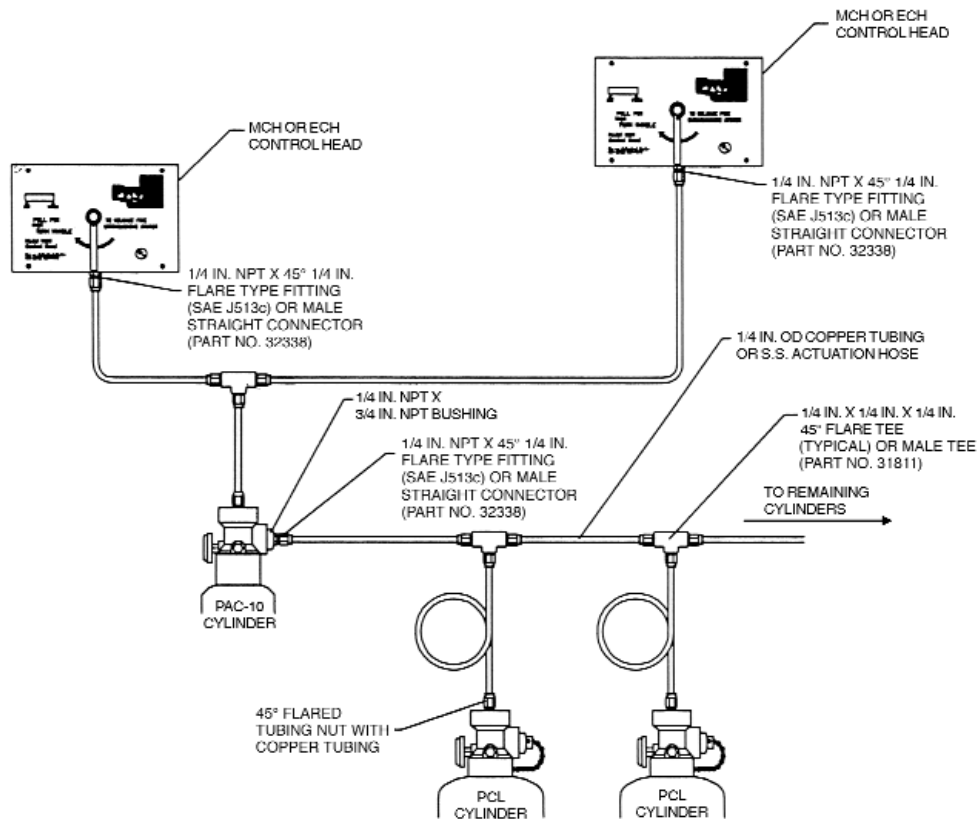

Figure 4-5a. Multiple Cylinder Actuation Using Two Control Heads.

006858

FUSIBLE LINK DETECTOR INSTALLATION

Fusible links are always used in conjunction with the Model MCH3/NMCH3 Mechanical Control Head. After mounting the cylinder and control head, the fusible link line can be installed. The first step to installing the fusible link line is to install the detector bracket(s). These brackets must be installed in the plenum area, hazard area, and in each duct. See **Chapter III** for detector placement guidelines.

Note: Only ML-style Fusible Links can be used.

- ▶ Connect the fusible link brackets together using 1/2 in. conduit and the conduit connectors supplied in the detector kit (Model FLK-1/1A). A PYRO-CHEM corner pulley must be used whenever a change in conduit direction is necessary. The conduit is connected to the control head through a knockout in the upper left-side corner.

In general, fusible links centered in the detector brackets

- ▶ are connected in series using 1/16 in. diameter stainless steel cable. The spring plate in the control head maintains tension on this series of fusible links. If the tension is released for any reason (i.e., a fusible link separates), the control head will operate and actuate the system. Maximum limitations for the fusible link detection line are as follows:

Fusible links can be installed with or without fusible link hangers (see **Chapter II** for description).

Fusible Link Line Limitations When Used With Model MCH3 and NMCH3 Control Heads and Part No. 415670 and 423250 Pulley Elbows

Maximum # of Detectors:	20
Maximum length of cable:	150 ft (45.7 m)
Maximum # of pulleys:	40

1. Fusible Link Installation Without Hangers.

Begin installing links at the terminal bracket. The link is connected to the far side of the terminal bracket using an “S” hook. The “S” hook must be crimped closed after the link is installed. A tight loop is then made in the cable and secured by the crimp provided. This loop is connected to the other side of the terminal link (see **Figure 4-6**) and the cable fed through the conduit to the next bracket. The cable proceeding from the terminal link will be used to connect the series links (see **Figure 4-7**). Series links must be centered in their detector brackets.

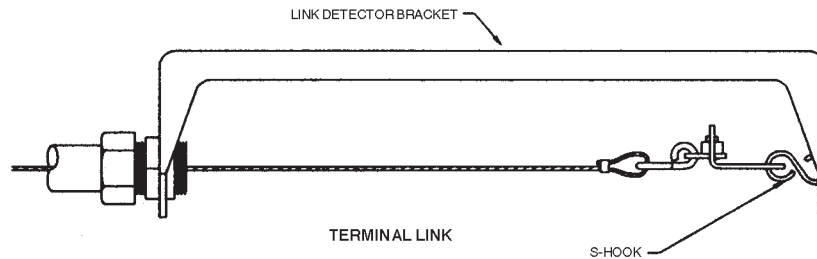

Figure 4-6. Terminal Link Installation.

002849aPC

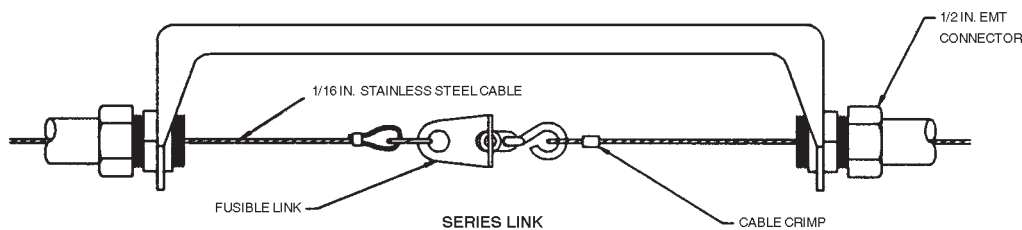

Figure 4-7. Series Link Installation.

002849bPC

After the last link in the series is connected, the cable should be fed through the conduit back to the control head. Thread the cable through the hole in the fusible link ratchet wheel. The line must then be crimped, and the crimp positioned inside the center of the ratchet wheel.

NOTE

Crimps must always be used in conjunction with two (2) cable lengths. Loops are the accepted method of connecting the cable to mechanical components. The crimp must never be used on a single cable.
 Exception: Single cable crimp allowed in detection and gas valve ratchet wheel using stop sleeve, Part No. 26317 (packages of 10: Part No. 24919).

The fusible link line can now be put into a set position by applying tension to the fusible link line. This is accomplished by using a 1/2 in. hex wrench on the fusible link line ratchet wheel. The ratchet wheel will be ratcheted in a clockwise direction until the spring plate makes contact with the top of the control head box. The fusible link line is now in a set position. See Figure 4-8.

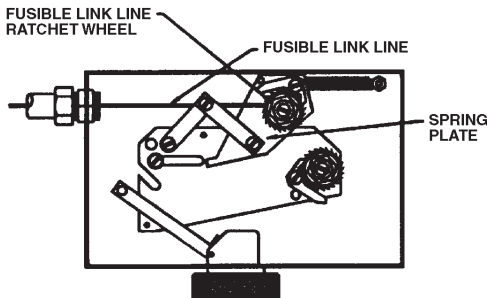

Figure 4-8. Fusible Link Line Termination.

002876PC

2. Fusible Link Installation Using Model FLH-1 Fusible Link Hangers.

Beginning at the control head, feed the stainless steel cable through the conduit and brackets to the terminal bracket in one continuous length. Allow approximately 2.5 in. (6.4 cm) of slack at each bracket for the installation of the Fusible Link Hangers. At the terminal link, a tight loop is made in the cable and secured by the crimp provided. The cable is attached to the far side of the terminal bracket using an "S" hook. The "S" hook must be crimped closed after the cable is installed. See Figure 4-9.

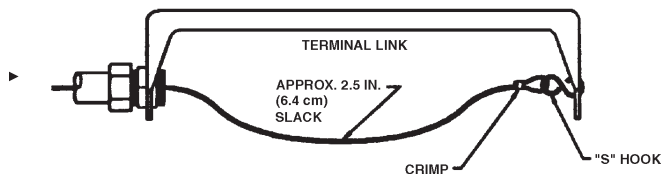

Figure 4-9. Terminal Bracket Connection.

002877PC

Begin installing the Fusible Link Hangers at the terminal bracket and work toward the control head. Loop the cable through the oval opening in the hanger and hook the fusible link on the loop. See Figure 4-10.

Note: Only ML-style Fusible Links can be used

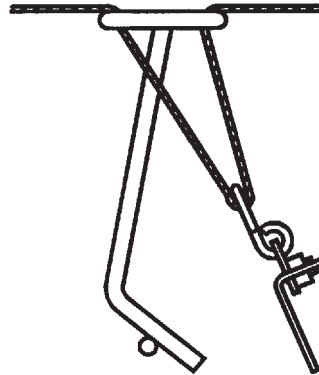

Figure 4-10. Fusible Link Connection.

002878PC

Hook the bottom of the link onto the bottom leg of the hanger. See Figure 4-11.

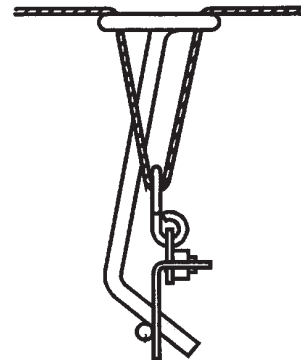

Figure 4-11. Fusible Link/Hanger Connection.

002879PC

Center the hanger/link in the fusible link bracket by sliding it along the link line. This is easily accomplished before any tension is applied to the link line. Repeat this procedure for all fusible links.

After the last hanger/link in the series is connected, the cable should be fed through the hole in the fusible link ratchet wheel. The line must then be crimped, and the crimp positioned inside the center of the ratchet wheel.

NOTE

Crimps must always be used in conjunction with two (2) cable lengths. Loops are the accepted method of connecting the cable to mechanical components. The crimp must never be used on a single cable.
 Exception: Single cable crimp allowed in detection and gas valve ratchet wheel using stop sleeve, Part No. 26317 (packages of 10: Part No. 24919).

The fusible link line can now be put into a set position by applying tension to the fusible link line. This is accomplished by using a 1/2 in. hex wrench on the fusible link line ratchet wheel. The ratchet wheel will be ratcheted in a clockwise direction until the spring plate makes contact with the top of the control head box. The fusible link line is now in a set position. See **Figure 4-8**. Check to ensure that the fusible link hanger(s) remain centered in the bracket after the fusible link line is set. See **Figure 4-12**.

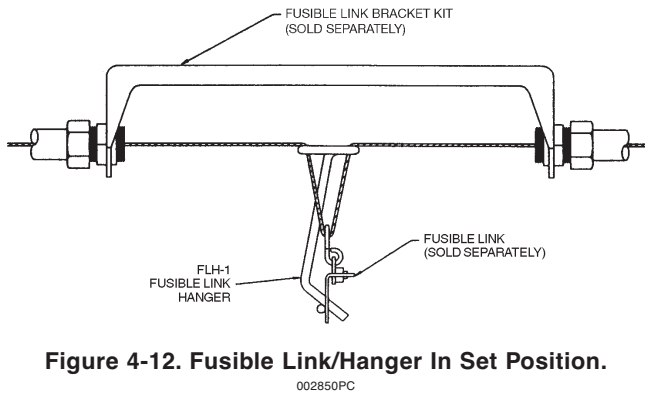

Figure 4-12. Fusible Link/Hanger In Set Position.

THERMAL DETECTOR INSTALLATION

Thermal detectors are always used in conjunction with the Model ECH3 Electrical Control Head. After mounting the cylinder and control head, the thermal detector(s) can be installed. See **Chapter III** for detector placement guidelines. Follow the instructions included with the detector for proper detector mounting procedures.

SETTING THE CONTROL HEAD

► 1. Model MCH3/NMCH3 Mechanical Control Head.

Once the fusible link line is set, the control head can be placed in the set position. To set the control head, the slide plate is moved from right to left, ensuring the bolt extending from the cam arm is in the slot provided in the slide plate. Continue moving the slide plate to the left until the latching arm is in the locked position. Insert the pull pin into the hole in the slide plate above the latching arm. This will lock the control head in the set position, eliminating accidental actuation during the rest of the installation procedure. See **Figure 4-13**.

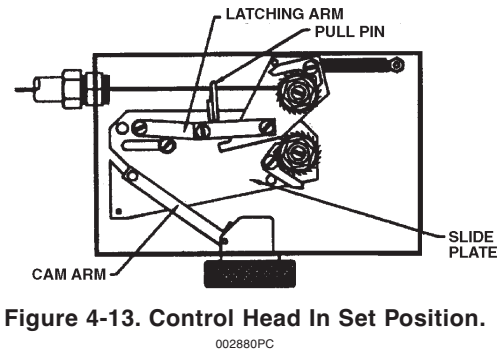

Figure 4-13. Control Head In Set Position.

2. Model ECH3 Electrical Control Head.

Once the thermal detectors have been installed, the control head can be placed in the set position. To set the control head, the slide plate is moved from right to left, ensuring the bolt extending from the cam arm is in the slot provided in the slide plate. Continue moving the slide plate to the left until the latching arm is in the locked position. Insert the pull pin into the hole in the slide plate above the latching arm. This will lock the control head in the set position, eliminating accidental actuation during the rest of the installation procedure.

Once the Model ECH3 Electrical Control Head is in the set position, it can be connected to the detection/actuation circuit.

NOTE

No electrical connections shall be made inside the control head. All electrical wiring shall exit the control head through the knock-out on the side of the box. All electrical connections must be made in an approved electrical box.

Connect one of the black wires on the solenoid in the control head to the red wire of the Model MS-SPDT Micro Switch. The brown wire from the micro switch is then connected to one side of the first thermal detector in series. Connect the other side of the first thermal detector in series and the remaining black wire on the solenoid in the control head to the appropriate power source after installing the Model SM-24/120 Solenoid Monitor.

CAUTION

The solenoid must never be wired "hot" (not through the micro-switch). If wired this way, the non-field replaceable solenoid will be damaged and the complete control head will require replacement.

NOTE

A Model SM-24/120 Solenoid Monitor must always be used with an Electrical Control Head to supervise the actuation/detection circuit.

The Model ECH3-24 Electrical Control Head requires a UL Listed 24VDC power supply with a minimum 2A rating. The Model ECH3-120 Electrical Control Head requires a 1A, 120VAC power supply.

SOLENOID MONITOR INSTALLATION

1. Solenoid Monitor Installation In Detection Circuit.

After installing the thermal detectors and the control head, the Model SM-120/24 Solenoid Monitor can be installed. The Solenoid Monitor is connected to the wires leading from the last thermal detector. It should be mounted in a location where it can be readily observed.

The Solenoid Monitor is an end-of-line device that supervises the actuation/detection circuit. It is comprised of a push-type switch with a built-in indicator light, a plug-type relay, a relay socket, and a cover plate. The light, when illuminated, indicates that the detection/actuation circuit is in the normal condition. The Solenoid Monitor also provides two sets of dry contacts. The Solenoid Monitor's cover plate is used to mount the Solenoid Monitor in a standard 6 in. x 4 in. x 3 in. deep electrical box (see **Figure 4-14**).

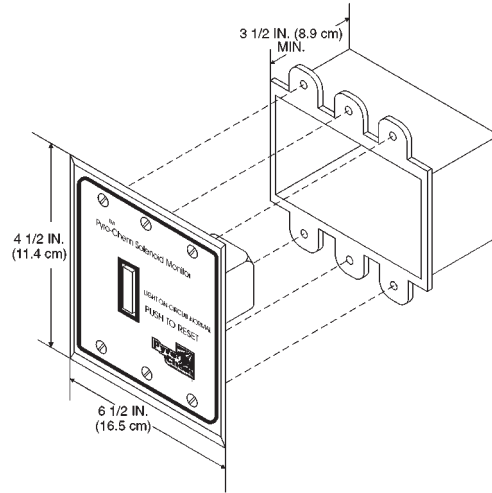

Figure 4-14. Solenoid Monitor Installation.
 002881PC

All wire for circuits using the Model SM-24 shall be 18 gauge minimum, or as required by local code. All wire for circuits using the Model SM-120 shall be 14 gauge minimum, or as required by local code. The basic wiring diagram for both the Model SM-24 and Model SM-120 is shown in **Figure 4-14.1**.

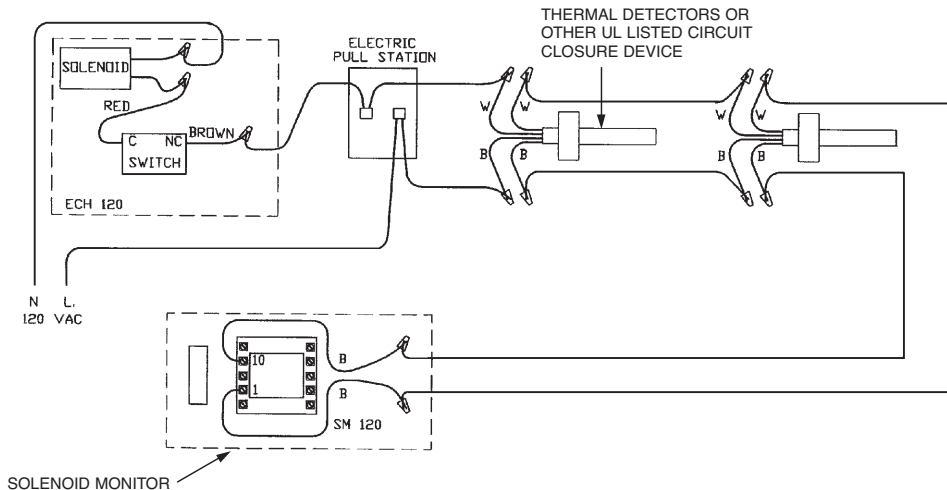

Figure 4-14.1. Wiring Diagram, Solenoid.

002882PC

After the Solenoid Monitor has been installed, the detection/actuation circuit can be connected to the appropriate power source and energized. To energize the detector/actuation circuit, depress the switch on the Solenoid Monitor. The light will illuminate to indicate that the circuit is properly installed. If the light fails to illuminate, the wiring must be checked.

2. Solenoid Monitor When Used As A Reset Relay

The Model SM-24/120 can be used as a reset relay when required. A reset relay is required whenever an electrical gas shut-off valve is used in conjunction with the PYRO-CHEM Open Face Paint Spray Booth Industrial Fire Suppression System. For typical wiring connections, see **Figure 4-15**.

REMOTE PULL STATION INSTALLATION

1. Model RPS-M.

The Model RPS-M Remote Mechanical Pull Station is used for remote mechanical actuation of the Model MCH3/ECH3/NMCH3 Control Head. It is to be located near an exit in the path of egress from the hazard area no more than 4 ft (1.2 m) above the floor.

NOTE:

A model RPS-M remote mechanical pull station must be used for manual actuation of a model NMCH3 releasing device.

The Pull Station can be surface mounted or recessed. It is connected to the control head using 1/16 in. diameter stainless steel cable. The cable enters the pull station box from the bottom, top, either side, or back. The cable enters the control head through the top-center knockout. The cable must be enclosed in 1/2 in. conduit with a PYRO-CHEM corner pulley at each change in conduit direction. Maximum limitations for the Model RPS-M Remote Mechanical Pull Station are as follows:

Model RPS-M Cable Run Limitations When Used With Model MCH3, ECH3, and NMCH3 Control Heads and Part No. 415670 and 423250 Pulley Elbows

- ▶ Maximum length of cable: 150 ft (45.7 m)
- ▶ Maximum # of pulleys: 40

▶ After mounting the pull station box and conduit, feed the stainless steel cable from the control head, through the conduit, and into the pull station box. Insert the bushing into the pull station's cover plate and secure it with the locknut provided. Feed the cable through the bushing and into the pull handle ensuring that the cable fully crosses the set screw hole. Fasten the cable to the pull handle with the set screw (see **Figure 4-16**).

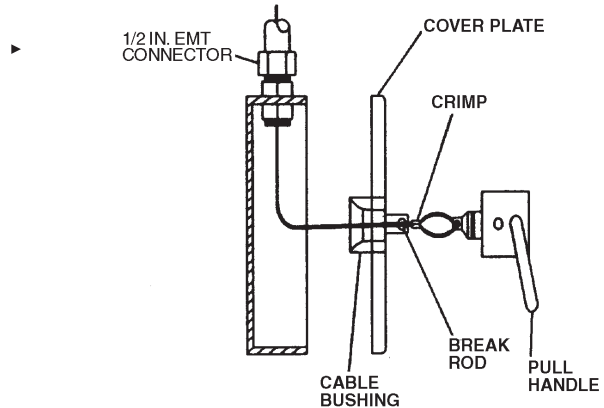

Figure 4-16. Model RPS-M Remote Pull Station Installation.

002884PC

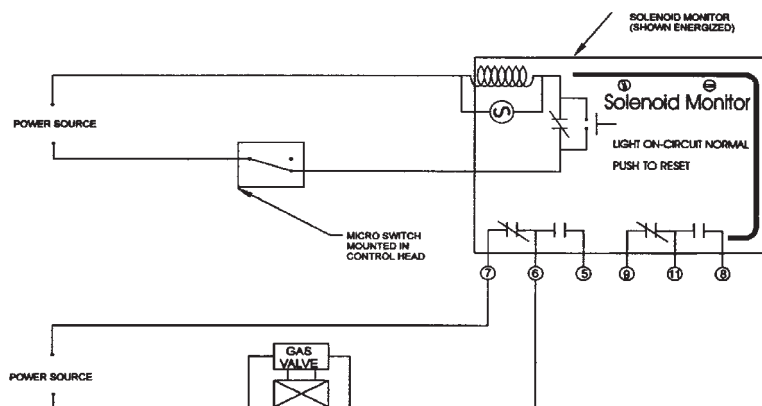

Figure 4-15. Solenoid Monitor Wiring With Electrical Gas Shutoff Valve.

002883PC

NOTE

Crimps must always be used in conjunction with two (2) cable lengths. Loops are the accepted method of connecting the cable to mechanical components. **The crimp must never be used on a single cable.** Exception: Single cable crimp allowed in detection and gas valve ratchet wheel using stop sleeve, Part No. 26317 (packages of 10: Part No. 24919).

Cut and thread the cable through the hole in the latching arm of the control head and pull the cable tight. Crimp the cable 6 in. (15.2 cm) below the latching arm.

Pull the pull handle until the crimp touches the latching arm. Coil the excess cable in the pull box and attach the cover plate with the four screws provided. Insert the pull handle into the cover plate and insert the pull pin through the bushing and the pull handle. Secure the pull pin with the nylon tie provided. See **Figure 4-17**.

2. Model RPS-E2.

The Model RPS-E2 remote electrical pull station is used for remote actuation of the Model ECH3 Control Head. It is to be located near an exit in the path of egress from the hazard area no more than 4 ft (1.2 m) above the floor. The Model RPS-E2 is installed in the detection/actuation circuit and wired in accordance with the instructions included. See **Figure 4-14.1** for typical circuit wiring.

GAS SHUT-OFF VALVE INSTALLATION

1. Mechanical Gas Shut-Off Valve Installation.

The Model MCH3/NMCH3 Control Head is used to operate the mechanical gas shut-off valve. This valve is located in the fuel gas supply line. The valve body has an arrow which indicates direction of gas flow through the valve. The gas shut-off valve is spring loaded and requires five pounds of force to hold it open. This force is supplied by a 1/16 in. diameter stainless steel cable that is connected to the control head. After the valve is installed in the gas line, 1/2 in. conduit must be run from the top center knockout of the gas valve box to the lower right-hand knockout in the control head. A PYRO-CHEM corner pulley is used wherever a change in conduit direction is required.

Gas Valve Cable Run Limitations When Used With Model NMCH3 or MCH3 Control Heads and Part No. 415670 and 423250 Pulley Elbows

Maximum length of cable:	100 ft (30.5 m)
Maximum # of pulleys:	30

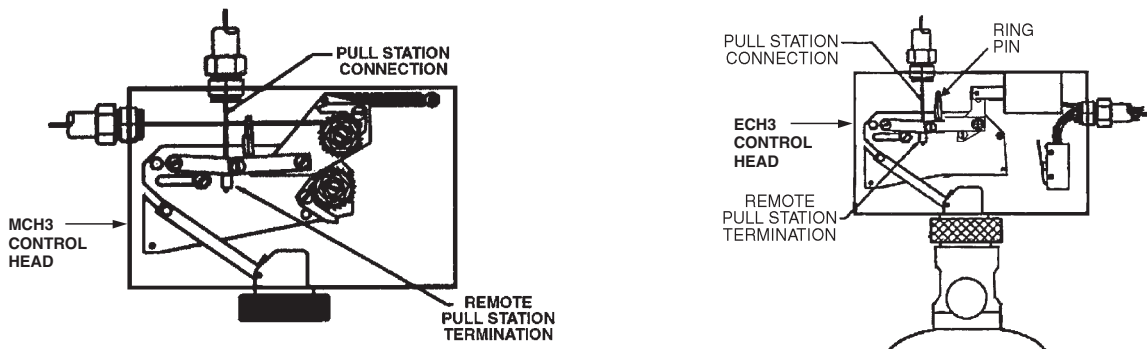

Figure 4-17. Model RPS-M Remote Pull Station Termination.

002885PC/003647PC

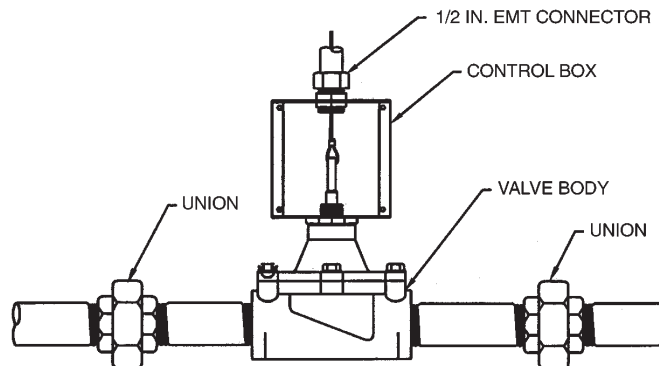

Figure 4-18. Gas Valve Installation.

002886PC

Remove the gas valve cover and thread the stainless steel cable through the conduit back to the control head. Thread the cable through the hole in the gas valve ratchet wheel. The line must then be crimped, and the crimp positioned inside the center of the ratchet wheel.

At the gas valve, loop the cable through the valve stem and secure it with the crimp provided (see **Figure 4-18**).

- **Note:** See Chapter 2 – Components for maximum dimension to extend valve stem.

The gas valve line can now be put into a set position by applying tension to the gas valve line. This is accomplished by using a 1/2 in. hex wrench on the gas valve ratchet wheel. The ratchet wheel will be ratcheted in a clockwise direction until the gas valve is fully open. Secure the gas valve cover plate to the gas valve box with the four (4) screws provided. The gas valve line is now in a set position. See **Figure 4-19**.

CAUTION

Overtightening the gas valve may cause the system not to actuate.

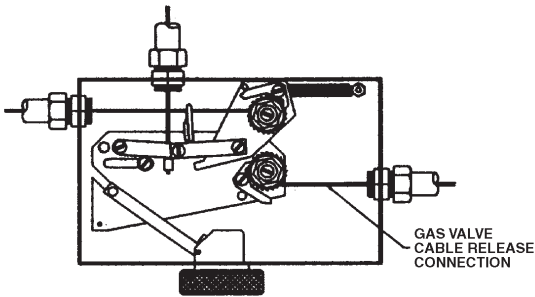

Figure 4-19. Gas Valve Line Termination.
 002887PC

2. Electrical Gas Shut-Off Valve Installation.

The Model MCH3/ECH3/NMCH3 Control Head is used to operate the electrical gas shut-off valve. This valve is located in the fuel gas supply line. The valve body has an arrow which indicates direction of gas flow through the valve. A reset relay must always be used with an electrical gas shut-off valve. For proper wiring of the electrical gas shut-off valve, see **Figure 4-15**.

TEE PULLEY INSTALLATION

The Model TP-1 Tee Pulley is used to connect two (2) mechanical gas valves or two (2) remote mechanical pull stations to a single control head. The cable proceeding from the control head must always enter the branch of the tee pulley. See **Figure 4-20**.

A tee pulley that is used to close two (2) gas valves can only be used to close gas valves with similar stem travel. Gas valves from 3/4 in. up to 1 1/2 in. can be used on the same tee pulley. A 2 in. gas valve can be used only with another 2 in. gas valve. Gas valves from 2 1/2 in. up to 3 in. can be used on the same tee pulley. As an example, using a 3/4 in. gas valve with a 3 in. gas valve will not allow the 3 in. valve to fully open.

CAUTION

The tee pulley must never be used to connect multiple fusible link lines to a single control head.

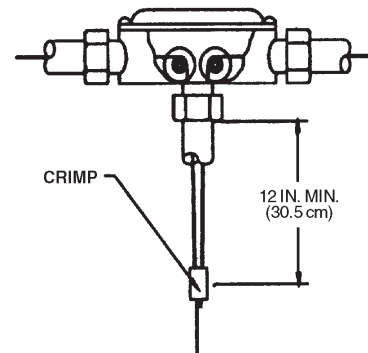

Figure 4-20. Tee Pulley Installation.
 002888PC

MICRO SWITCH INSTALLATION

See NFPA 72, “National Fire Alarm Code,” Initiating Devices section, for the correct method of wiring connection to the fire alarm panel.

The Model MS-SPDT, MS-DPDT, MS-3PDT, or MS-4PDT Micro Switch is available for use where an electrical output is required. These switches can be field installed in the control head. See **Figure 4-21** and **Figure 4-22** and refer to Instruction Sheet, Part No. 551159, included with switch shipping assembly, for detailed mounting instructions.

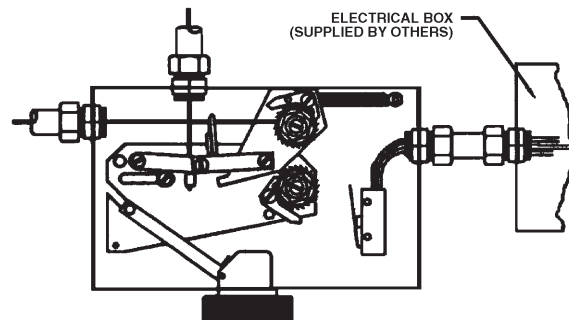

Figure 4-21. Micro Switch Installation in Model MCH3/NMCH3 Control Head.
 002889PC

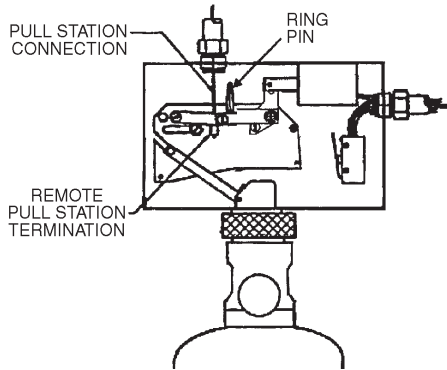

Figure 4-22. Micro Switch Installation in Model ECH3 Control Head.

003647PC

NOTE

The Model ECH3 Control Head is supplied with a Model MS-DPDT Micro Switch. This switch can be used in the actuation/detection circuit and for electrical output.

These switches may be used to provide an electrical signal to the main breaker and/or operate electrical accessories provided the rating of the switch is not exceeded. Wiring connections are shown in **Figure 4-23**. The contact ratings for the switches are as follows:

Contact Ratings For Micro Switches
 21 amps, 1 HP, 125, 250, 277 VAC
 or 2 HP, 250, 277 VAC

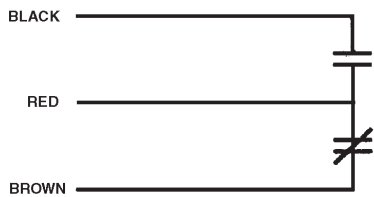
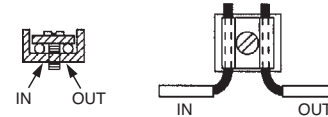
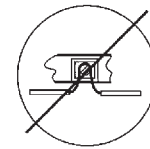
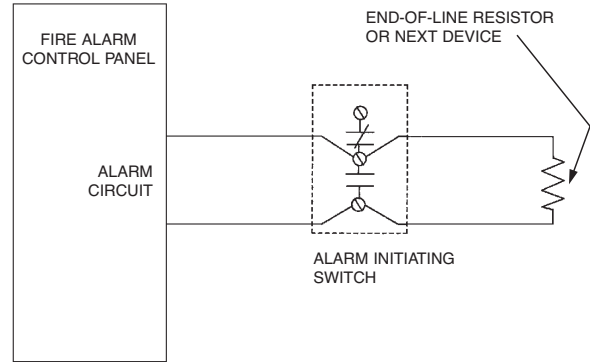

Figure 4-23. Wiring Diagram For Model MS-SPDT Micro Switch.

002903PC

The Alarm Initiating Switch, Part No. 550077, must be used to close a supervised alarm circuit to the building main fire alarm panel when the control head actuates. This will signal the fire alarm panel that there was a system actuation in the hazard area. This switch can be field installed in the control head. Refer to Instruction Sheet, Part No. 550081, included with the switch shipping assembly, for detailed mounting instructions. Wiring connections are shown in **Figure 4-24**. The switch is rated at 50mA, 28VDC.



CORRECT – SEPARATE INCOMING AND OUTGOING CONDUCTORS

Figure 4-24. Wiring Diagram for Alarm Initiating Switch.

004891/004905

PIPE AND NOZZLE INSTALLATION

General Piping Requirements

1. Use Schedule 40 black iron (if used in a relatively non-corrosive atmosphere), galvanized, chrome-plated, or stainless steel pipe conforming to ASTM A120, A53, or A106. Fittings must be a minimum of 150 lb Class. However, the PCI 35, 50, and 70 lb cylinders must have a minimum of two (2) nozzles per cylinder to utilize the 150 lb Class fittings. If the PCI 35, 50, or 70 lb cylinder has one (1) nozzle, then a 300 lb Class fitting must be used. The remaining Monarch cylinders have no limitations for the 150 lb Class fittings. Distribution pipe sizes are 3/4 in. or 1 in. depending on number of nozzles.
2. Pipe unions are acceptable.
3. Use reducing tees for all pipe splits.
4. Reducing bushings are not acceptable.
5. Cast iron pipe and fittings are not acceptable.
6. **Pipe thread sealant or pipe joint compound is not allowed for distribution piping.**
7. Bell Reducer or any non-restrictive fittings are allowed.
8. Before assembling the pipe and fittings, make certain all ends are carefully reamed and blown clear of chips and scale. Inside of pipe and fittings must be free of oil and dirt.

- ▶ 9. If Teflon tape is used on threaded ends, start at the second male thread and wrap the tape clockwise around the threads, away from the pipe opening.
- ▶ 10. All system piping must comply with Section A-5-9.1 of NFPA-17.

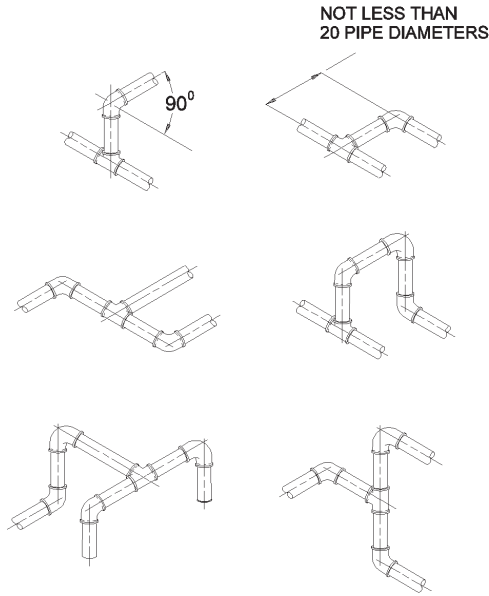

▶ **Figure 4-25. Acceptable Piping Methods.**

002965PC

CAUTION

Do not apply Teflon tape to cover or overlap the pipe opening, as the pipe and nozzles could become blocked and prevent the proper flow of agent

▶ **TEE POSITIONING**

In order to obtain equal distribution at a tee, the dry chemical must enter the side port of the tee and exit through the two end ports. See **Figure 4-26**.

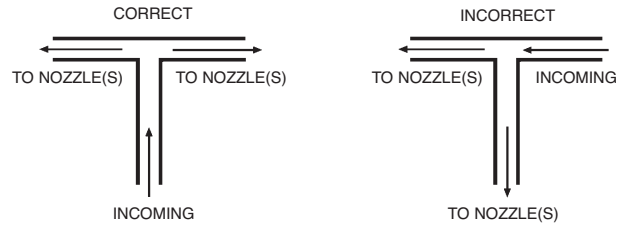

Figure 4-26. Tee Positioning

003126

Hanger/Support Installation

The hanger/supports must be installed in conjunction with the pipe and fittings. The spacing requirements for hangers/supports depend on the pipe size being utilized; refer to the Spacing Guidelines Chart.

PIPE HANGER SPACING GUIDELINES CHART

Distribution Pipe Size	Maximum Spacing Distance Hanger to Hanger	
	ft	m
▶ 1/4	4	(1.2)
▶ 1/2	6	(1.8)
▶ 3/4	8	(2.4)
▶ 1	12	(3.6)

Other factors that influence hanger/support spacing are:

- ▶ Hanger/Support must be placed within 1 ft (0.3 m) of the discharge nozzle.

Hanger/Support must be placed between elbows when distance is greater than 2 ft (0.6 m).

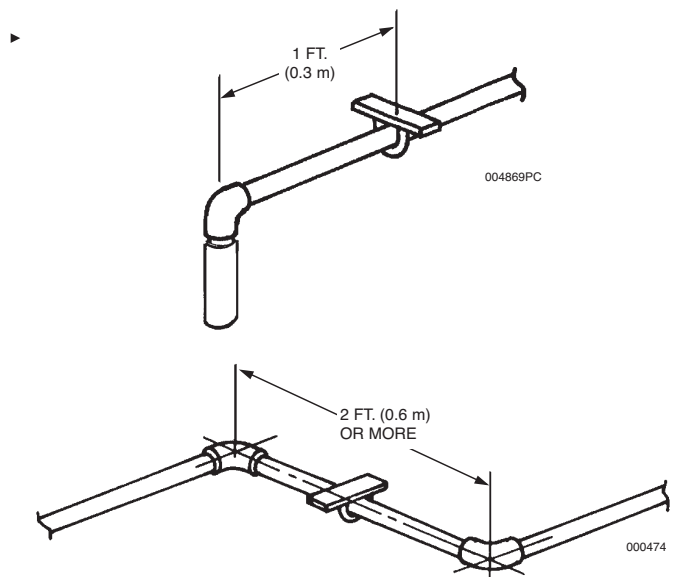

▶ **Figure 4-27. Hanger/Support.**

MAIN/RESERVE SYSTEM

When a reserve system is being utilized, two 1 in. swing check valves, Part No. 417788, must be installed in the distribution piping network. They should be positioned as close as possible to the “Y” fitting joining the piping from the main and reserve tanks to one common supply pipe. See **Figure 4-28**. **Note:** Make certain to install swing check valves in the direction of dry chemical flow as shown with an arrow stamped on the valve body.

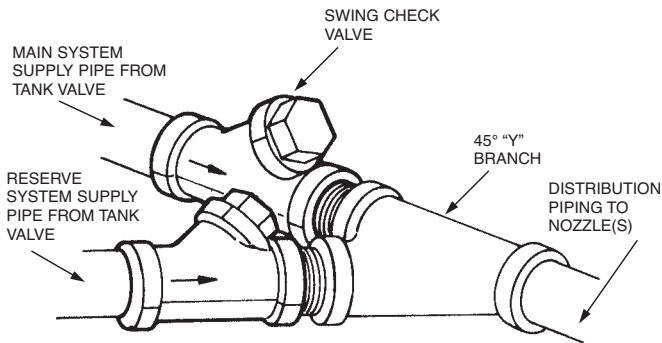

Figure 4-28. Main/Reserve System.

000480

PRESSURE SWITCH INSTALLATION

The Model PS-SPDT-X Pressure Switch is available for use when an electrical output is required. It must be installed in the discharge piping within 12 in. (30.5 cm) of the valve discharge port as shown in **Figure 4-29**. An inline tee is used for the installation. The switch is isolated from the chemical by a 12 in. to 15 in. (30.5 to 38.1 cm) column of air in the form of a vertical pipe nipple. The switch is then mounted at the top of this nipple.

NOTE

Piping for pressure switch must be included in total cylinder to T1 piping limitations. The fitting used to connect the pressure switch to the distribution piping counts as one (1) elbow in that section.

As an alternate, the switch may be connected directly to the copper tubing of a remotely mounted control head or a PAC cylinder. The PS-SPDT-X counts as one cylinder in this section, and the limitations on copper tubing and/or pipe previously stated in this manual apply.

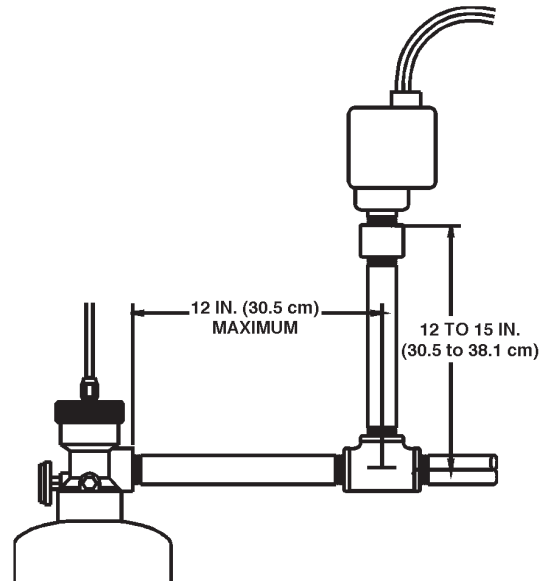

Figure 4-29. Pressure Switch Installation.

003025PC

SYSTEM CHECKOUT AFTER INSTALLATION

1. Model MCH3/NMCH3 Mechanical Control Head.

Before putting the system into service, all components must be checked for proper operation. During this checkout, assure that the carbon dioxide pilot cartridge is not installed in the control head actuator. Remove the pull pin from the hole in the slide plate.

To check satisfactory operation of the control head, cut the terminal link or the “S” hook holding the link. This will relieve all tension on the fusible link line and operate the control head. The slide plate will move fully to the right. The gas valve cable will be released, causing the gas valve to close. Any auxiliary equipment connected to the dry contacts of the solenoid monitor and/or the Micro Switch in the control head will operate.

If any of these events fail to occur, the problem must be investigated and repaired.

Repair the terminal link and put the fusible link line back into the set position. This is accomplished by using a 1/2 in. hex wrench on the fusible link line ratchet wheel. The ratchet wheel will be ratcheted in a clockwise direction until the spring plate makes contact with the top of the control head box.

Once the fusible link line is set, the control head can be placed in the set position. To set the control head, the slide plate is moved from right to left, ensuring the bolt extending

from the cam arm is in the slot provided in the slide plate. Continue moving the slide plate to the left until the latching arm is in the locked position.

Once the control head is set, pull the pull handle on the remote pull station to assure that the control head operates. If the control head operates normally, the control head can be reset as described above. Insert the pull pin into the hole in the slide plate above the latching arm. Replace the pull station handle, pull pin, and nylon tie.

Assure that the gas valve is fully open by ratcheting the gas valve ratchet wheel.

Using a felt-tipped marker, write the date of installation on the carbon dioxide pilot cartridge. Screw the cartridge into the control head actuator until hand-tight. **Never use a wrench to tighten the cartridge into the actuator.**

Remove the pull pin from the hole in the slide plate and install the control head cover. Insert the pull pin through the local manual control handle and into the bushing. Secure the pull pin with the nylon tie provided.

2. Model ECH3-24/120 Electrical Control Head.

Before putting the system into service, all components must be checked for proper operation. During this checkout, ▶ assure that the CO₂ pilot cartridge is not installed in the control head actuator. Remove the pull pin from the hole in the slide plate.

CAUTION

Make certain to remove the CO₂ cartridge. Failure to do so during testing will result in system actuation.

Testing Thermal Detectors

1. Remove the electric control head cover.
2. Test each detector individually and recock release mechanism after each test.

- ▶ 3. Using a heat gun positioned approximately 12 in. from the detector, apply heat to the detector for about one minute. Overheating will cause damage to the detector. Applying heat to the detector will cause the control head to operate. When the control head operates, the following will take place: a) The slide plate will move fully to the right; b) The indicator light on the solenoid monitor will go out; and c) Any auxiliary equipment connected to the dry contacts of the solenoid monitor and/or the micro switch in the control head will operate. If any of these events fail to occur, the problem must be investigated and repaired.
4. After all the thermal detectors have cooled, the control head can be placed in the set position. To set the control head, the slide plate must be moved from right to left, ensuring the bolt extending from the cam arm is in the slot provided in the slide plate. Continue moving the slide plate to the left until the latching arm is in the locked position.

Testing Remote Pull Station

1. Once the control head is set, pull the pull handle on the remote pull station to assure that the control head operates. If the control head operates normally, the control head can be reset as described in Step 4 above.
2. Insert the pull pin into the hole in the slide plate above the latching arm.
- ▶ 3. Replace the pull station handle, pull pin, and break rod.

▶ Completing System Checkout

- ▶ 1. Energize the actuation/detection circuit by depressing the push button on the solenoid monitor.
- ▶ 2. Using a felt-tipped marker, write the date of installation on the CO₂ pilot cartridge. Ensure that the actuator has an O-ring installed, and screw the cartridge into the control head actuator until hand tight. **Never use a wrench to tighten the cartridge into the actuator.**
- ▶ 3. Remove the pull pin from the hole in the slide plate and install the control head cover. Insert the pull pin through the local manual control handle and into the bushing. Secure the pull pin with the tie provided.

NOTE

Refer to NFPA-17 for additional inspection requirements.

NOTES:

CHAPTER V SYSTEM MAINTENANCE

GENERAL

This chapter will detail the basic information necessary for proper maintenance of the PYRO-CHEM Industrial Fire Suppression System. However, before attempting any system maintenance, it is necessary to attend a Factory Certification Training Class and become Certified to install and maintain the PYRO-CHEM Industrial Open Face Paint Spray Booth Fire Suppression System.

MAINTENANCE AFTER SYSTEM DISCHARGE

1. System Cleanup.

The hazard area cleanup after a system discharge is very basic. The dry chemical agent should be cleaned up by either sweeping or vacuuming. Residual dry chemical should be wiped off effected surfaces with a damp cloth.

2. System Cylinder Recharge.

CAUTION

Protective eye goggles and protective footwear must be worn when performing system maintenance.

1. Remove the cylinder from the control head or pneumatic adaptors and inspect for visual damage. If there is any damage the cylinder must be hydrostatically tested before being refilled. If there is no damage, the cylinder can be recharged.
2. Reset all pneumatic actuators (Models PDA-D2) by depressing the check valve on top and relieving the pressure. Remove the pneumatic actuator or control head from the valve and use any 1/4-20 UN screw or bolt to screw into the top of the piston. Pull up on the piston until the piston is flush with the top of the valve body and remove the screw or bolt from the piston.
3. Remove the valve and siphon tube assembly from the cylinder and unscrew the siphon tube from the valve.
4. Inspect the valve to make sure no mechanical damage has occurred. If there is evidence of any damage to the seals, rebuild the valve using the Dry Valve Rebuilding Kit (PYRO-CHEM Part Number 550037).
5. Screw the siphon tube back into the valve.

6. Refill the cylinder with agent. Use the table below for easy reference.

<u>Cylinder</u>	<u>Recharge</u>
PCI-15ABC	12.5 lb ABC (Part No. 550696)
PCI-25sABC	25 lb ABC (Part No. 550696)
PCI-35ABC	35 lb ABC (Part No. 550696)
PCI-50sABC	50 lb ABC (Part No. 550696)
PCI-70ABC	70 lb ABC (Part No. 550696)

The Model RC-50ABC (Part No. 550696) is a 50 lb pail of ABC dry chemical recharge agent available from PYRO-CHEM.

7. Insert the siphon tube into the cylinder, and screw the valve onto the cylinder. Make sure that the valve is screwed completely into the cylinder.
8. Attach the Recharge Adaptor (PYRO-CHEM Part No. 550130) to the discharge port of the valve. The adaptor O-ring should be completely inside the discharge port. Attach a source of dry nitrogen to the adaptor.

Charge the cylinder with dry nitrogen to 350 psi at 70°F.

NOTE

1. The pressure gauge attached to the cylinder valve should not be used to determine when the charging pressure has been reached. A pressure regulator should be used.
2. Higher pressure may be needed during the initial charging stage to blow the agent out of the siphon tube. Secure the cylinder during this stage, as it may jump as the agent is blown from the siphon tube.

9. Slowly disconnect the nitrogen source from the Recharge Adaptor. The cylinder valve will close when the Recharge Adaptor is depressurized. When the valve is closed and the nitrogen source is disconnected from the Recharge Adaptor, remove the recharge adaptor from the valve discharge port. Immediately screw the recoil preventer into the discharge port.

CAUTION

The recoil preventer must remain in the valve discharge port until the cylinder is attached to the piping network.

10. Reinstall the cylinder to the piping network. Reattach the control head or pneumatic adaptor.

3. Piping and Nozzles.

- ▶ Piping should be blown out with air or dry nitrogen. Nozzle blow off caps should be replaced.

4. System Reset.

All fusible links should be replaced. The fusible link line can now be put into a set position by applying tension to the

- ▶ fusible link line. This is accomplished by using a 1/2 in. hex
- ▶ wrench on the fusible link line ratchet wheel. The ratchet wheel will be ratcheted in a clockwise direction until the spring plate makes contact with the top of the control head box. The fusible link line is now in a set position.

After setting the fusible link line, the system can be put back into service by following the SYSTEM CHECKOUT AFTER INSTALLATION Section of **Chapter IV**.

REGULAR SYSTEM MAINTENANCE

1. Six (6) Month Maintenance.

1. Check that the hazard has not changed.
2. Check that all nylon ties are in place and the system has not been tampered with.
3. Check the entire system for mechanical damage.
- ▶ 4. Check the solenoid monitor.
- ▶ 5. Disconnect the control head or pneumatic tubing from each agent cylinder. Remove the carbon dioxide pilot cartridge and exercise the control head to ensure it is functioning properly. Make sure the gas shut-off valve and the remote pull station are functioning properly.

NOTE

Before continuing, remove the cover from the control head and insert the pull pin in the hole in the slide plate above the latching arm. This will secure the system, preventing accidental discharge.

- ▶ 6. Inspect fusible link detectors for excessive grease buildup. Clean or replace links if necessary. Visually inspect thermal detectors.

NOTE

Methods and frequency of inspection, testing and maintenance of detectors should be in accordance with NFPA-72.

- ▶ 7. Reinstall the carbon dioxide pilot cartridge and replace the control head cover and nylon tie.

CAUTION

Before screwing the carbon dioxide pilot cartridge into the actuator, ensure that the actuator has an O-ring installed.

8. Inspect the cylinder pressure. Tap the gauge lightly to ensure the needle is moving freely. If the gauge shows a loss in pressure indicated by the needle being below the green band, the tank should be removed and recharged per the SYSTEM CYLINDER RECHARGE section of Chapter V (System Maintenance) in this manual.

2. Annual Maintenance.

1. Inspect as per six (6) month maintenance instructions.
2. Disconnect and remove the discharge piping from the system. Using air or nitrogen, blow out the discharge piping. Replace all nozzle caps.
- ▶ 3. Fixed temperature sensing elements of the fusible alloy type shall be replaced at least annually or more frequently, if necessary, to assure proper operation of the system.
- ▶ 4. Test thermal detectors and remote pull station per SYSTEM CHECKOUT AFTER INSTALLATION section located in Chapter IV (System Installation) of this manual. Per NFPA 72, two (2) or more detectors per circuit should be tested. Note individual detector location and date of testing. Within 5 years, all detectors in system must be tested.
5. Replace the carbon dioxide pilot cartridge, recording the date of installation on the cartridge with a felt-tipped marker.

CAUTION

Before screwing the carbon dioxide pilot cartridge into the actuator, ensure that the actuator has an O-ring installed.

3. Six (6) Year Maintenance.

1. Inspect as per annual maintenance instructions.
2. Examine the dry chemical. If there is evidence of caking, the dry chemical shall be discarded.

4. Hydrostatic Testing.

The dry chemical agent cylinder(s) and pneumatic cylinder(s) shall be hydrostatically tested at least every twelve (12) years as per NFPA-17.

NOTE

Refer to NFPA-17 for additional maintenance requirements.

**MONARCH™ INDUSTRIAL
FIRE SUPPRESSION
SYSTEM**



by Tyco Fire Suppression & Building Products

**GENERAL PURPOSE:
TOTAL FLOODING/LOCAL APPLICATION**

TECHNICAL MANUAL

- **COMPONENTS**
- **DESIGN**
- **INSTALLATION**
- **MAINTENANCE**

Copyright © 2010 Tyco Fire Suppression & Building Products

February 1, 2010

TABLE OF CONTENTS

<u>Page</u>	<u>Subject</u>	<u>Revision</u>	<u>Date</u>	<u>Page</u>	<u>Subject</u>	<u>Revision</u>	<u>Date</u>
General Information				Design (Continued)			
1-1	General Information	1	2/1/10	3-2Local Application— Overhead Guidelines— Total Flood0-5% Unclosable OpeningGreater than 5% Unclosable Opening	3	2/1/10
Components				3-3	Local Application Tankside	1	3/17/04
2-1	Cylinders & Valves	2	3/17/04	3-4	Piping Limitations – PCI-25sABC w/2 Nozzle	2	9/1/06
2-2	Nozzles Cylinder Bracketing MCH3 Control Head	3	2/1/10	3-5	Piping Limitations – PCI-50sABC/BC w/4 Nozzles	3	9/1/06
2-3	ECH3 Control Head NMCH3 Control Head MB-P2 Mounting Bracket PDA-D2 Adaptor	2	3/17/04	3-6	Local Application Overhead	2	9/1/06
2-4	Pneumatic Actuating CylindersPAC-10PAC-200	2	3/17/04	3-7	Piping Limitations – PCI-25sABC/BC w/2 Nozzles	2	9/1/06
2-5	Detection EquipmentFLK-1FLK-1AFLH-1	2	3/17/04	3-8	Piping Limitations – PCI-50sABC/BC w/4 Nozzles	3	9/1/06
2-6Fusible LinksThermal Detectors RPS-M Mechanical Pull Station	4	2/1/10	3-9	Total Flooding with ABC	1	3/17/04
2-7	RPS-E2 Electric Pull Station Gas Shut-off ValvesMechanicalElectrical	3	9/1/06	3-10	Total Flooding Nozzle Protection Chart	1	3/17/04
2-8	Corner PulleysSBP-1CBP-1WBP-1 Tee Pulley Swing Check Valve	2	3/17/04	3-11	Piping Limitations – PCI-17ABC w/1 Nozzle	1	3/17/04
2-9	Electrical SwitchesMicroAlarm Initiating SM-120/24 Solenoid Monitor	3	9/1/06	3-12	Piping Limitations – PCI-35ABC w/2 Nozzles	2	9/1/06
2-10	Pipe and Fittings Stainless Steel Actuation Hose Pressure Switches Pressure Bleed Down Adaptor Flow Restrictor	2	3/17/04	3-13	Piping Limitations – PCI-70ABC w/4 Nozzles	3	9/1/06
2-11	Component List	3	2/1/10	3-14	Piping Limitations – PCI-70ABC with 6 Nozzles	2	9/1/06
2-12	Component List (Continued)	2	3/17/04	3-15	Detector Placement	2	2/1/10
Design				3-16	Notes		3/17/04
3-1	General Choosing the Proper Agent Choosing the Proper Type of System System TypesLocal Application – Tankside	1	3/17/04	Installation			
				4-1	General Cylinder Installation Control Head Installation –Single Cylinder	2	3/17/04
				4-2Multiple Cylinders	2	3/17/04
				4-3Multiple Cylinders – PAC-10 or PAC-200	2	3/17/04
				4-4Multiple Cylinders – Two Control Heads	2	3/17/04
				4-5	Fusible Link Detector InstallationFusible Links Without Hangers	2	3/17/04
				4-6Fusible Links With Hangers	2	3/17/04
				4-7	Thermal Detector Installation Setting The Control HeadMCH3/NMCH3 Control HeadECH3 Control Head	2	3/17/04
				4-8	Solenoid Monitor InstallationIn A Detection Circuit	2	3/17/04

<u>Page</u>	<u>Subject</u>	<u>Revision</u>	<u>Date</u>	<u>Page</u>	<u>Subject</u>	<u>Revision</u>	<u>Date</u>
<u>Installation (Continued)</u>							
4-9When Used as a Reset Relay Remote Pull Station InstallationRPS-M	2	3/17/04				
4-10RPS-E2 Gas Shut-off Valve InstallationMechanical	3	9/1/06				
4-11Electrical Tee Pulley Installation Micro Switch Installation	3	9/1/06				
4-12	Pipe and Nozzle Installation	3	9/1/06				
4-13	Tee Positioning	2	3/17/04				
4-14	Main/Reserve System Pressure Switch Installation System Checkout After InstallationMechanical Control Head	2	3/17/04				
4-15Electrical Control Head		3/17/04				
4-16	Notes		3/17/04				
<u>Maintenance</u>							
5-1	General Maintenance After DischargeSystem CleanupSystem Cylinder Recharge	3	2/1/10				
5-2Piping and NozzlesSystem Reset Regular System Maintenance6 Month MaintenanceAnnual Maintenance6 Year MaintenanceHydrostatic Testing	2	3/17/04				

CHAPTER I

General Information

INTRODUCTION

PYRO-CHEM automatic dry chemical fire suppression systems are of the pre-engineered type as defined by the NFPA Standard for Dry Chemical Extinguishing Systems, NFPA-17. The extinguishing units described in this manual are intended to be installed, inspected, and maintained in accordance with NFPA-17. Limitations detailed in this manual have been established through extensive testing by Underwriters Laboratories, Inc. Installation and maintenance of the system must conform to the limitations detailed in this manual and be performed by an Authorized PYRO-CHEM dealer.

The PYRO-CHEM Industrial Fire Suppression System utilizes either a sodium bicarbonate based dry chemical agent (specifically designed to suppress liquid, gas or electrical fires) or a monoammonium phosphate based dry chemical agent (specifically designed to suppress carbonaceous solid, liquid, gas or electrical fires). The system provides mechanical or electrical automatic actuation and can be manually actuated through a remote mechanical pull station. Upon actuation, the system discharges a pre-determined amount of agent to the hazard area.

The shutdown of fuel and power to the hazard area is required upon system actuation. Exhaust fan(s) in the ventilation system must be shut off during system discharge to allow the proper concentration of agent to build up in the hazard area.

TEMPERATURE LIMITATIONS

The operating temperature ranges of the PYRO-CHEM System are:

Monoammonium Phosphate (ABC) Total Flooding Systems: -20 °F (-28 °C) minimum to 120 °F (49 °C) maximum.

Local Application – Overhead Systems: 32 °F (0 °C) minimum to 120 °F (49 °C) maximum.

Local Application – Tankside Systems: -20 °F (-28 °C) minimum to 120 °F (49 °C) maximum.

UL LISTING

The PYRO-CHEM Industrial Fire Suppression System has been tested to the UL Standard for Pre-Engineered Dry Chemical Extinguishing System Units, UL1254 (Revised Sept. 29, 1998), and Listed by Underwriters Laboratories, Inc.

CITY OF NEW YORK APPROVAL

The PYRO-CHEM Industrial Fire Suppression System is approved by the City of New York Fire Department per Certificate of Approval No. 5544 under the following conditions:

1. Prior to installation, plans must be filed with and accepted by New York City Department of Buildings. Additionally, a copy of New York City Department of Buildings docketed plans shall be transmitted to the Fire Department for review and approval.
2. The system shall be installed, periodically inspected, tested and otherwise maintained in accordance with Sections 901, 904.1.1 and 904.4 of New York City Fire Code, NFPA 17 and all applicable New York City Construction Code/Fire Code. Electrical wiring shall be in accordance with the New York City Electrical Code.
3. At least once a month, an inspection shall be conducted by a trained and knowledgeable person to assess that the system is in good working order.
4. The installation, maintenance procedures, and limitations stated in this manual must be complied with.

CHAPTER II COMPONENTS

CYLINDERS & VALVE

PYRO-CHEM automatic dry chemical systems are supplied in 17 pound, 25 pound, 35 pound, 50 pound, and 70 pound capacity cylinders. They are the Models PCI-15ABC, PCI-17ABC, PCI-25sBC, PCI-25sABC, PCI-35ABC, PCI-50sBC, PCI-50sABC, and PCI-70ABC. Each cylinder must be separately piped to its own nozzles. All models are charged with dry nitrogen to 350 psi @ 70° F. **These systems are for indoor hazard protection only.** The particular models are as follows:

► **PCI-15ABC.** This system is charged with 12.5 pounds of monoammonium phosphate-based dry chemical, PYRO-CHEM Part No. 550170. It is Listed for use in total flooding applications. It is rated to protect Class “A,” “B,” and “C” hazards.

► **PCI-17ABC.** This system is charged with 17 pounds of monoammonium phosphate based dry chemical, PYRO-CHEM Part No. 550170. It is Listed for use in total flooding applications. It is rated to protect Class “A,” “B,” and “C” hazards.

► **PCI-25sBC.** This system is charged with 25 pounds of regular sodium bicarbonate based dry chemical, PYRO-CHEM Part No. 550162. It is Listed for use in local overhead and

local tankside applications. It is rated to protect only Class “B” and “C” hazards.

► **PCI-25sABC.** This system is charged with 25 pounds of monoammonium phosphate based dry chemical, PYRO-CHEM Part No. 550170. It is Listed for use in local overhead and local tankside applications. It is rated to protect Class “A,” “B,” and “C” hazards.

► **PCI-35ABC.** This system is charged with 35 pounds of monoammonium phosphate based dry chemical, PYRO-CHEM Part No. 550170. It is Listed for use in total flooding applications. It is rated to protect Class “A,” “B,” and “C” hazards.

► **PCI-50sBC.** This system is charged with 50 pounds of regular sodium bicarbonate based dry chemical, PYRO-CHEM Part No. 550162. It is Listed for use in local overhead and local tankside applications. It is rated to protect only Class “B” and “C” hazards.

► **PCI-50sABC.** This system is charged with 50 pounds of monoammonium phosphate based dry chemical, PYRO-CHEM Part No. 550170. It is Listed for use in local overhead and local tankside applications. It is rated to protect Class “A,” “B,” and “C” hazards.

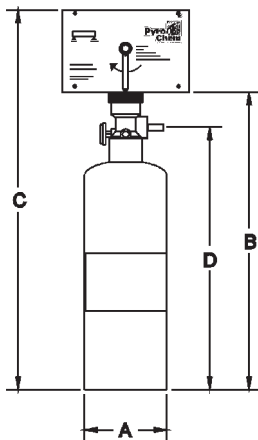

MODEL NO.	A	B	C	D	WEIGHT	MOUNTING BRACKET USED
PCI-15ABC	6.00	21.44	27.19	18.69	30 lb	MB-15
PCI-17ABC	8.00	24.81	30.56	22.06	50 lb	MB-15
PCI-25sABC/BC	8.00	24.81	30.56	22.06	58 lb	MB-15
PCI-35ABC	10.00	29.94	35.69	27.18	71 lb	MB-1
PCI-50sABC/BC	10.00	29.94	35.69	27.18	86 lb	MB-1
PCI-70ABC	12.00	35.31	41.06	32.56	130 lb	MB-1

ALL DIMENSIONS IN INCHES

Figure 2-1 Cylinder and Valve Assemblies

002841PC

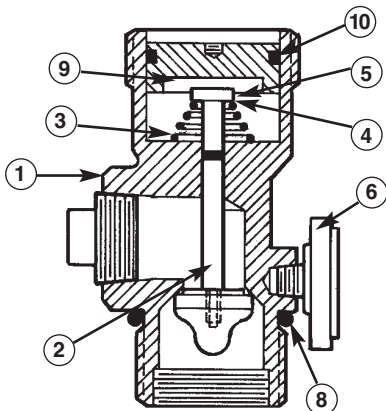

ITEM	PART NO.	DESCRIPTION
1	---	VALVE BODY
2	---	VALVE STEM & CAP ASSEMBLY
3	550022	CONICAL SPRING
4	550261	RETAINING WASHER
5	550024	E-RING
6	550025	PRESSURE GAUGE
7	550026	HIGH TEMPERATURE RELIEF PLUG
8	550029	VALVE BODY O-RING
9	550805	PISTON
10	550636	PISTON O-RING

Figure 2-2 Valve Cross Section

002842PC

PCI-70ABC. This system is charged with 70 pounds of monoammonium phosphate based dry chemical, PYRO-CHEM Part No. 550170. It is Listed for use in total flooding applications. It is rated to protect Class “A,” “B,” and “C” hazards.

The dimensions of the PCI-15/17/25s/35/50s/70 cylinder and valve assemblies are shown in **Figure 2-1**. The cylinder is manufactured, tested, and marked in accordance with DOT specification 4BW350.

The valve shown in **Figure 2-2** is a pressure sealed, poppet type valve. It is used on the PCI-15/17/25s/35/50s/70, PAC-10, and PAC-200 cylinders. The valve discharge port is 3/4 in. NPT.

NOZZLES

Nozzles have been developed for total flooding, local application overhead, and local application tankside. The Model NF-ABC nozzle is used for total flooding protection. The Model N-SCR nozzle is used for screening the opening. The Model N-OTF nozzle is used for overhead total flooding application in the work area. The Model N-PLU nozzle is used for overhead application in the plenum area. The Model N-DCT nozzle is used for exhaust duct protection. The Models N-LA-ABC and N-LA-BC nozzles are used for local overhead application. The Model N-TS nozzle is used for local tankside application. See **Figure 2-3**.

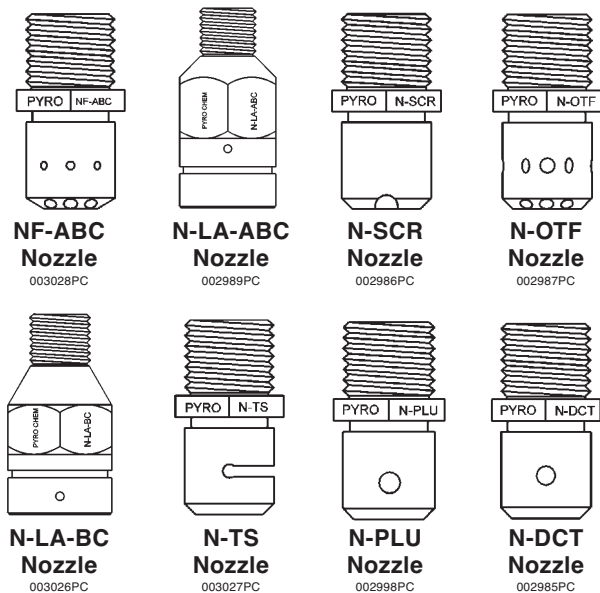

Figure 2-3. Nozzles.

CYLINDER BRACKETING

Vertical wall mounting for the **PCI-15ABC**, **PCI-17ABC**, and **PCI-25sBC/ABC**, is provided by the Model **MB-15** mounting bracket kit. Vertical wall mounting for the **PCI-35ABC**, **PCI-50sBC/ABC** and **PCI-70ABC** is provided by the Model **MB-1** mounting bracket kit. See **Figure 2-4**.

- ▶ For vertical floor mounting of the **PCI-17ABC**, **PCI-25sBC** and **PCI-25sABC**, an 8 in. channel-type mounting bracket is available, the Model **MB-U8**.

For vertical floor mounting of the **PCI-35ABC**, **PCI-50sBC**, and **PCI-50sABC**, a 10 in. channel-type mounting bracket is available, the Model **MB-U10**.

- ▶ For vertical floor mounting of the **PCI-70ABC**, a 12 in. channel-type mounting bracket is available, the Model **MB-U12**.

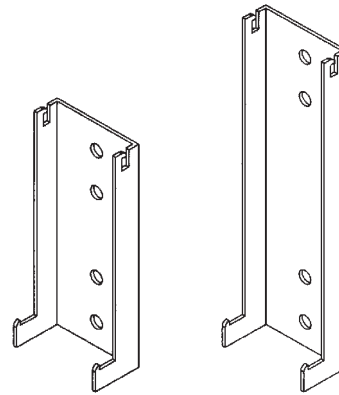

Figure 2-4 Mounting Brackets MB-15 and MB-1.

002843PC

MODEL MCH3 – MECHANICAL CONTROL HEAD

The Model MCH3 mechanical control head is a fully mechanical control head which can be connected to the PCI-15/17/25s/35/50s/70 cylinder valve. This control head will support a fusible link detection system, a remote mechanical pull station (Model RPS-M), and a mechanical or electric gas shut-off valve. A micro switch (Model MS-SPDT, MS-DPDT, MS-3PDT, or MS-4PDT) can be ordered separately and field installed. It is equipped with a local manual control handle that allows for mechanical system actuation. Operation of the local manual control requires removing the pull pin and rotating the handle clockwise. The Model MCH3 control head can actuate a maximum of five (5) cylinders. See **Figure 2-5**.

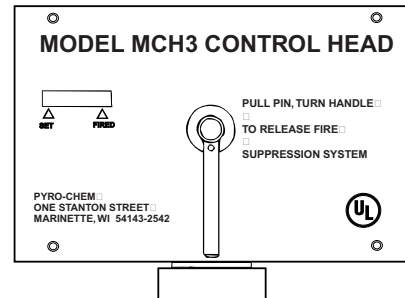

Figure 2-5. Mechanical Control Head.

004790PC

MODEL ECH3 – ELECTRIC CONTROL HEAD

The Model ECH3 electric control head is an electrically operated control head which can be connected to the PCI-15/17/25s/35/50s/70 cylinder valve. This control head will support an electric thermal detection system, a remote mechanical pull station (Model RPS-M), and an electric gas shut-off valve. It will not support a fusible link detection system. A micro switch (Model MS-DPDT) is included. The Model ECH3 control head is available in both 120 VAC (Model ECH3-120) and 24 VDC (Model ECH3-24). It is equipped with a local manual control handle that allows for mechanical system actuation. Operation of the local manual control requires removing the pull pin and rotating the handle clockwise. The Model ECH3 control head can actuate a maximum of five (5) cylinders. See **Figure 2-6**.

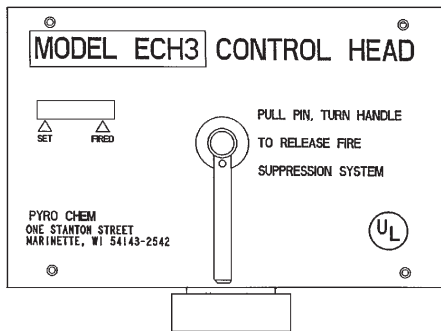

Figure 2-6. Electric Control Head.
 004789PC

MODEL NMCH3 – MECHANICAL CONTROL HEAD

The Model NMCH3 Mechanical Control Head is a fully mechanical control head which can be connected to the PCI-15/17/25s/35/50s/70 cylinder valve. This control head will support a fusible link detection system, a remote mechanical pull station (Model RPS-M), and a mechanical or electric shut-off valve. A micro switch (Model MS-SPDT, MS-DPDT, MS-3PDT, or MS-4PDT) can be ordered separately and field installed. There is no local manual actuation for the Model NMCH3. The Model NMCH3 control head can actuate a maximum of five (5) cylinders. See **Figure 2-6a**.

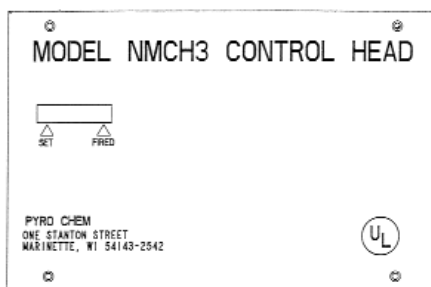

Figure 2-6a. Mechanical Control Head.
 006843PC

MODEL MB-P2 - CONTROL HEAD MOUNTING BRACKET

The Model MB-P2 mounting bracket must be used to mount the Model MCH3, NMCH3 or ECH3 control head if the control head is not mounted directly on a cylinder valve. See **Figure 2-7**.

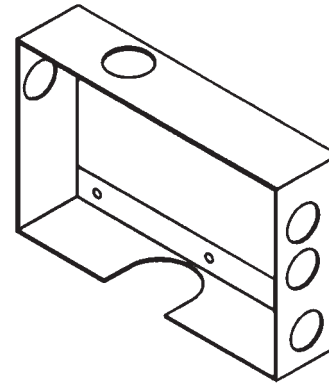

Figure 2-7. Model MB-P2 – Control Head Mounting Bracket.

002846PC

CAUTION

Do not screw the control head directly to a wall as this will warp the control head, not allowing the mechanism to actuate.

MODEL PDA-D2 PNEUMATIC ACTUATING ADAPTOR

The Model PDA-D2 Pneumatic Actuating Adaptor is used to open the cylinder valve when the system is actuated. It must be installed on the valve of each cylinder unless a control head has been mounted on the cylinder valve. See **Figure 2-7a**.

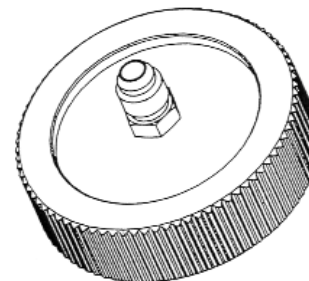

Figure 2-7a. Model PDA-D2 Pneumatic Actuating Adaptor.

006886PC

PNEUMATIC ACTUATING CYLINDERS

1. Model PAC-10.

The Model PAC-10 is a pneumatic actuating cylinder that can actuate a maximum of ten (10) agent cylinders simultaneously. The Model PAC-10 includes a DOT 4BA350 cylinder pressurized with dry nitrogen to 350 PSIG @ 70° F, a brass valve with pressure gauge, and a wall mounting bracket. A Model MCH3, NMCH3 or ECH3 control head must be purchased separately and connected to the PAC-10 to open the valve. See Figure 2-8.

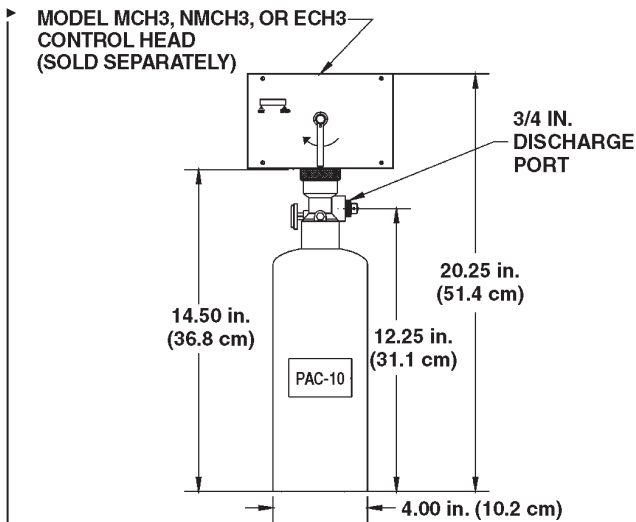

Figure 2-8. Model PAC-10 Pneumatic Actuating Cylinder.

002847PC

2. Model PAC-200.

The Model PAC-200 is a pneumatic actuating cylinder that can actuate a maximum of twenty (20) agent cylinders simultaneously. The Model PAC-200 includes a DOT 4BA350 cylinder pressurized with dry nitrogen to 350 PSIG @ 70° F, a brass valve with pressure gauge, and a wall mounting bracket. A Model MCH3, NMCH3 or ECH3 control head must be purchased separately and connected to the PAC-200 to open the valve. See Figure 2-9.

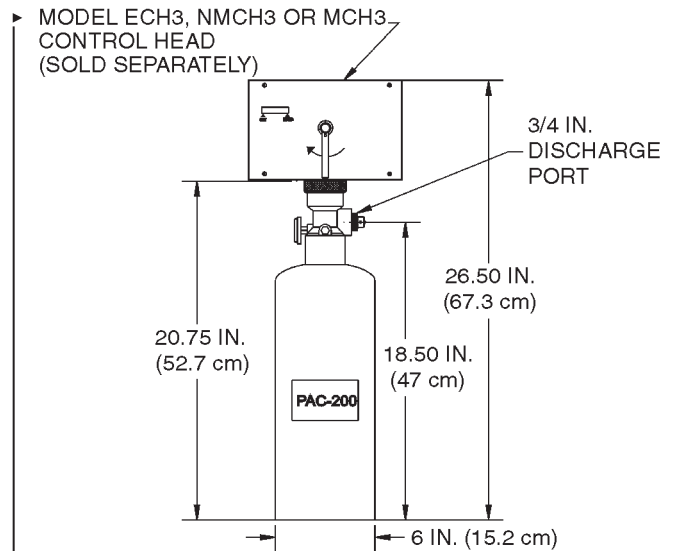

Figure 2-9. Model PAC-200 Pneumatic Actuating Cylinder.

002848PC

DETECTION EQUIPMENT

1. Model FLK-1.

- ▶ The Model FLK-1 fusible link kit includes a 10 in. steel bracket, two (2) 1/2 in. EMT connectors, two (2) cable crimps, and two (2) “S” hooks. Fusible links must be ordered separately. **See Figure 2-10.**

2. Model FLK-1A.

- ▶ The Model FLK-1A fusible link kit includes an 8 in. steel bracket, two (2) 1/2 in. EMT connectors, two (2) cable crimps, and two (2) “S” hooks. Fusible links must be ordered separately.

3. Model FLH-1.

The Model FLH-1 fusible link hanger is an accessory designed to simplify the installation of fusible links in the fusible link line. It can be used with the Model FLK-1/1A fusible link kits (kits must be ordered separately). The Fusible Link Hanger makes it possible to install fusible links without cutting and crimping loops in the fusible link line for each link. They are available in packages of 25 (FLH-25) only. **See Figure 2-11.**

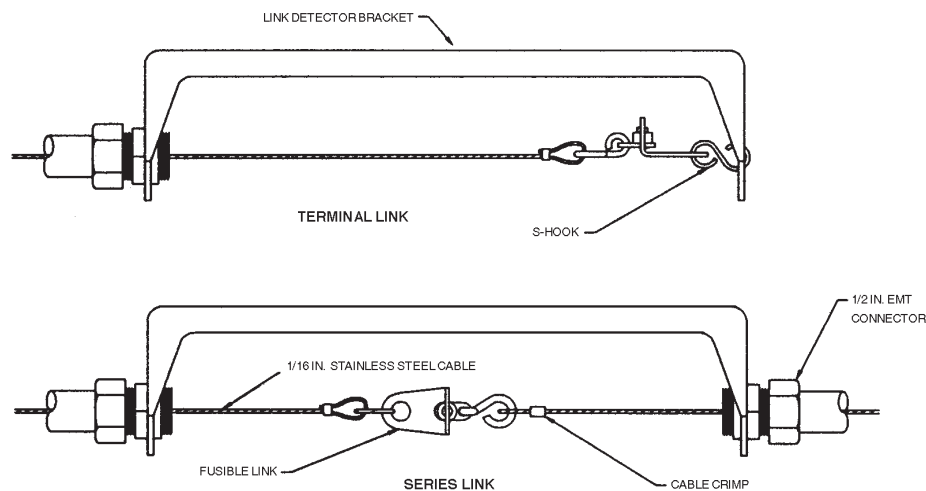

Figure 2-10. Model FLK-1 Fusible Link

002849PC

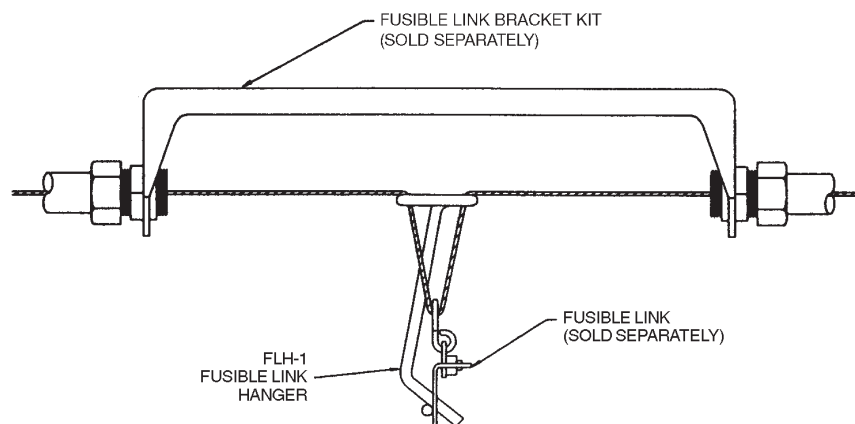

Figure 2-11. Model FLH-1 Fusible Link Hanger

002850PC

4. Fusible Links.

The fusible link is designed to separate at a specific temperature, releasing tension from the fusible link line, causing system actuation. **See Figure 2-12.**

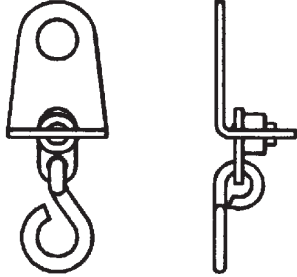

Figure 2-12. ML Style Fusible Link.

002851PC

After determining the maximum ambient temperature at the fusible link location, select the correct fusible link according to the temperature condition chart below:

Fusible Link Model No.	Maximum Ambient Temperature
FL-165	100° F (38° C.)
FL-212	150° F (66° C.)
FL-280	225° F (107° C.)
FL-360	290° F (143° C.)
FL-450	360° F (182° C.)
FL-500	400° F (204° C.)

5. Thermal Detectors.

Rate compensated temperature thermal detectors are normally open, mechanical contact closure switches designed to operate at a factory preset temperature. They are available in six preset temperatures which meet NFPA standards and are UL Listed and FM Approved.

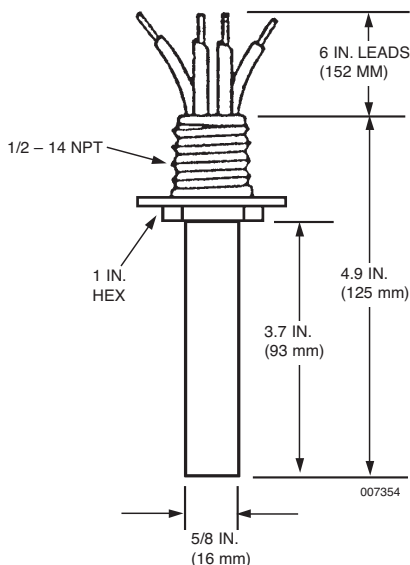

Figure 2-12a. Thermal Detector.

After determining the maximum ambient temperature at the thermal detector location, select the correct thermal detector according to the temperature condition chart below:

Thermal Detector Model No.	Maximum Ambient Temperature
TD-190	150° F (66° C.)
TD-225	185° F (85° C.)
TD-325	285° F (141° C.)
TD-450	410° F (210° C.)
TD-600	560° F (293° C.)

REMOTE MECHANICAL PULL STATION

Model RPS-M

Remote manual control for system releasing devices is provided by the Model RPS-M remote mechanical pull station. It is connected to the system releasing device by stainless steel cable. This cable is enclosed in 1/2 in. EMT with corner pulleys at each change in direction. The remote mechanical pull station shall be located at the point of egress from the hazard area. **See Figure 2-13.**

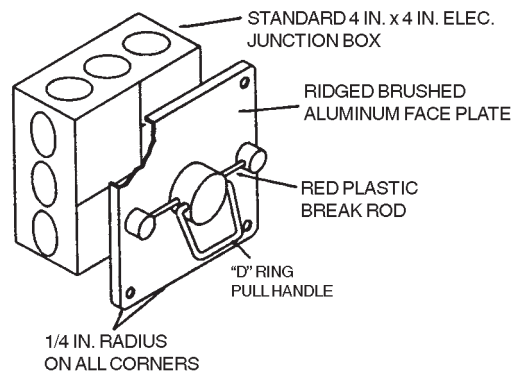
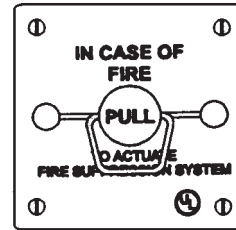
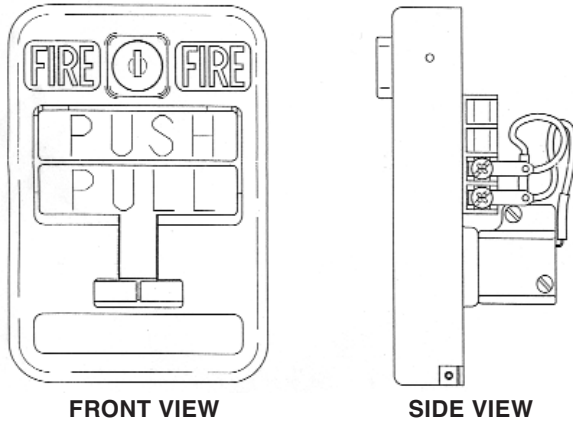

Figure 2-13. Model RPS-M Mechanical Pull Station.

002852PC

Model RPS-E2

Remote manual actuation for the Model ECH control head is provided by the Model RPS-E2 remote electric pull station. Installation instructions are provided in the installation section of this manual. The remote electric pull station shall be located at the point of egress.



FRONT VIEW **SIDE VIEW**
Figure 2-13a. Model RPS-E2
Remote Electric Pull Station.

006887PC

GAS SHUT-OFF VALVES

1. Mechanical Gas Shut-off Valve.

A gas shut-off valve is required on all systems used to protect a gas fueled appliance to stop gas flow in the event of system actuation. A mechanical gas valve can be used with either the Model MCH3 or NMCH3 control head. It is connected to the system control head by stainless steel cable. This cable is enclosed in 1/2 in. EMT conduit with a corner pulley at each change in direction. The valves are rated for natural and LP gas (see **Figure 2-14**). Mechanical gas valves are available in the following sizes:

Model No.	Valve Size	Maximum Operating Pressure	Dim. "A"
GV-75	3/4 in.	5 psi	3/8 in.
GV-100	1 in.	5 psi	3/8 in.
GV-125	1-1/4 in.	5 psi	15/32 in.
GV-150	1-1/2 in.	5 psi	15/32 in.
GV-200	2 in.	5 psi	15/32 in.
GV-250	2-1/2 in.	5 psi	29/32 in.
GV-300	3 in.	5 psi	29/32 in.

*Note: "A" maximum is full open position of valve. Do not exceed.
 Distortion of internal parts can result.

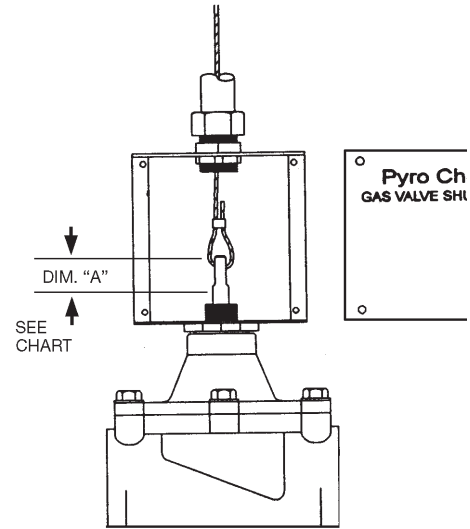

Figure 2-14. GV-Series Mechanical Gas Valve.

002853PC

2. Electric Gas Shut-off Valve.

A gas shut-off valve is required on all systems used to protect a gas fueled appliance to stop gas flow in the event of system actuation. A UL Listed electric gas valve can be used with either the Model MCH3, NMCH3 or ECH3 control head. The valves are rated for natural and LP gas. Valves are available in 120 VAC. Electric gas valves are available in the following sizes:

Model No.	Valve Size	Maximum Operating Pressure
EGVSO-75	3/4 in.	50 psi
EGVSO-100	1 in.	25 psi
EGVSO-125	1-1/4 in.	25 psi
EGVSO-150	1-1/2 in.	25 psi
EGVSO-200	2 in.	25 psi
EGVSO-250	2-1/2 in.	25 psi
EGVSO-300	3 in.	25 psi

Note: A UL Listed manual reset relay is required when using an electric gas valve. The PYRO-CHEM Model SM-120 solenoid monitor may be used for this purpose.

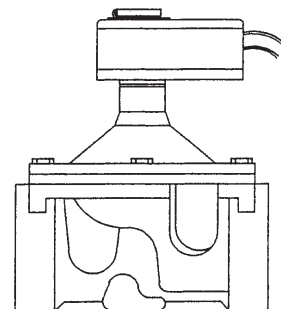

Figure 2-14a. Electric Gas Shut Off Valve.

006844PC

CORNER PULLEYS

1. Model SBP-1.

A corner pulley is used whenever a change in stainless steel cable direction is required. The Model SBP-1 corner pulley is equipped with a set screw fitting for connection to 1/2 in. EMT. See Figure 2-15.

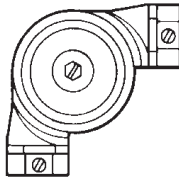

Figure 2-15. Model SBP-1 Corner Pulley.
000160

2. Model CBP-1.

A corner pulley is used whenever a change in stainless cable direction is required. The Model CBP-1 is a grease-tight corner pulley designed for areas likely to experience excessive deposit build-up. It is equipped with a compression fitting for connection to 1/2 in. EMT. See Figure 2-16.

Note: The Model CBP-1 is not a liquid tight sealing device.

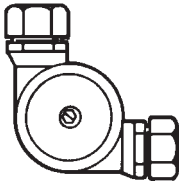

Figure 2-16. Model CBP-1 Corner Pulley.
000161

3. Model WBP-1.

A corner pulley is used whenever a change in stainless cable direction is required. The Model WBP-1 is a liquid-tight corner pulley designed for areas likely to experience excessive moisture build-up. It is equipped with a female pipe thread for connection to 1/2 in. rigid conduit. See Figure 2-17.

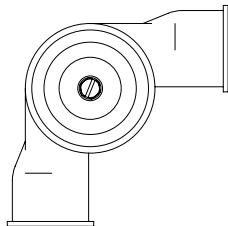

Figure 2-17. Model WBP-1 Corner Pulley.
006194PC

TEE PULLEY

The Model TP-1 tee pulley is used to connect two mechanical gas valves or two remote mechanical pull stations to a single control head. The tee pulley replaces two standard 90° corner pulleys. See Figure 2-18.

CAUTION

The Tee Pulley must never be used to connect multiple fusible link lines to a single control head.

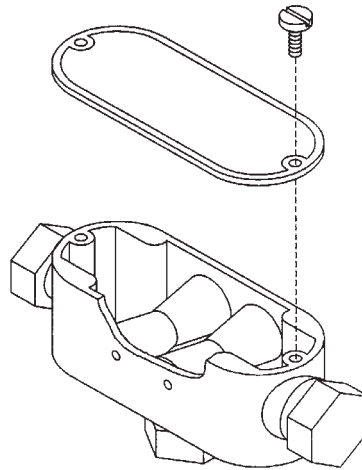

Figure 2-18. Model TP-1 Tee Pulley.
002857PC

SWING CHECK VALVE

The Swing Check Valve, Part No. 417788, is required when piping a main and reserve Monarch tank on the same distribution piping. It allows the dry chemical agent to discharge through the agent piping leading to the discharge nozzles, while preventing it from flowing into the piping from the other tank. The swing check valve body is constructed of brass with a 1 in. NPT female thread. See Figure 2-19.

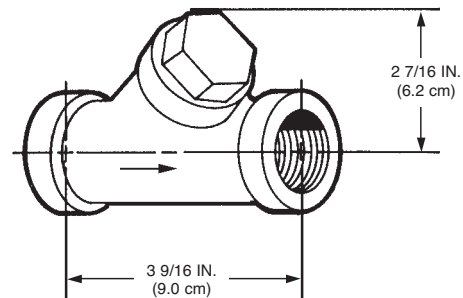

Figure 2-19. Swing Check Valve.
000430

ELECTRICAL SWITCHES

The electrical switches are intended for use with electric gas valves, alarms, contactors, lights, contractor supplied electric power shut-off devices and other electrical devices that are designed to shut off or turn on when the system is actuated.

Switches are available in kits: One Switch Kit, Part No. 551154; Two Switch Kit, Part No. 551155; Three Switch Kit, Part No. 551156, and Four Switch Kit, Part No. 551157. Mounting hardware and 12 in. wire assemblies are provided with each kit. Each switch has a set of single-pole, double-throw contacts rated:

UL/cUL/CSA Rating
 250 VAC, 21A Resistive
 250 VAC, 2 HP
 125 VAC, 1 HP

ENEC Rating
 IE4T105 μ Approved
 250V, 21A Resistive
 8A Motor Load

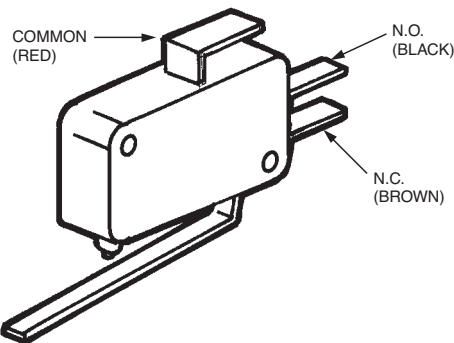

Figure 2-20a. Model MS-SPDT Micro Switch.

001612

The Alarm Initiating Switch Kit, Part No. 550077, can be field mounted within the control head. This switch must be used to close a supervised alarm circuit to the building main fire alarm panel when the control head actuates. This action will signal the fire alarm panel that there was a system actuation in the hazard area. The switch kit contains all necessary mounting components along with a mounting instruction sheet. The switch is rated 50 mA, 28 VDC.

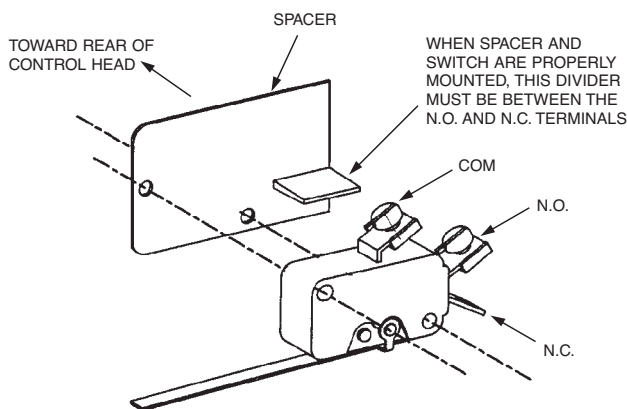

Figure 2-20b. Alarm Initiating Switch.

004890

See NFPA 72, "National Fire Alarm Code," Initiating Devices section, for the correct method of wiring connection to the fire alarm panel.

MODEL SM-120/24 SOLENOID MONITOR

The Model SM-120/24 solenoid monitor is used in conjunction with the Model ECH3 control head to supervise the actuation and detection circuits. In the event of a problem in the circuit, a light on the monitor goes out. The Model SM-120 is used with the Model ECH3-120 control head. The Model SM-24 is used with the Model ECH3-24 control head. Two sets of NO/NC dry contacts are provided. The unit mounts directly to a three gang wall outlet box. The Model SM-120 acts as a reset relay when used with an electric gas valve. Electric gas valve wiring instructions are provided in the installation section of this manual. See Figure 2-21.

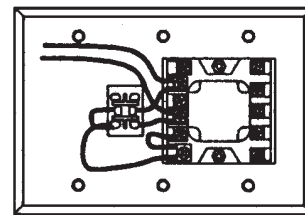
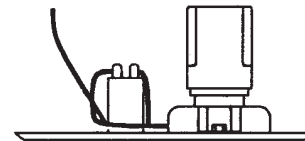
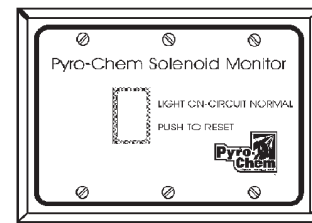

Figure 2-21. Model SM-24/120 Solenoid Monitor.

002860PC

PIPE & FITTINGS

Pipe and fittings must be furnished by the installer. Schedule 40 black, galvanized, chrome plated, or stainless steel pipe must be used. Standard weight malleable, galvanized, chrome plated, or stainless steel fittings must also be used.

STAINLESS STEEL ACTUATION HOSE

The Stainless Steel Actuation Hose is used to connect the actuation line compression tees and can also be connected end to end. The hose has the same thread, 7/16-20, as the fittings.

See Figure 2-22.

Hose Part No.	Length
417582	8 in. (20 cm)
31809	16 in. (41 cm)
32336	24 in. (61 cm)
430815	42 in. (107 cm)

Fitting Part No.	Description
31810	Male Elbow (7/16-20 x 1/4 in. NPT)
31811	Male Tee (7/16-20 x 7/16-20 x 1/4 in. NPT)
32338	Male Straight Connector (7/16-20 x 1/4 in. NPT)



Figure 2-22. Stainless Steel Actuation Hose.

000433

PRESSURE SWITCHES

Model PS-SPDT-XP.

The Model PS-SPDT-XP is an explosion proof (NEMA 4; 7; 9) electrical pressure switch which can be field mounted in the discharge piping as shown in Figure 2-23. The switch is UL Listed (CCN: NOWT) and must be installed in accordance with the instructions contained with the switch and this manual. The switch provides one set of NO/NC dry contacts. It is intended for use with electric power shut-off devices (dealer supplied), electric gas valves, alarms, bells, lights, contactors, and other electrical devices designed to shut off or turn on upon system actuation. It is rated for 15 amps @ 125/250 VAC.

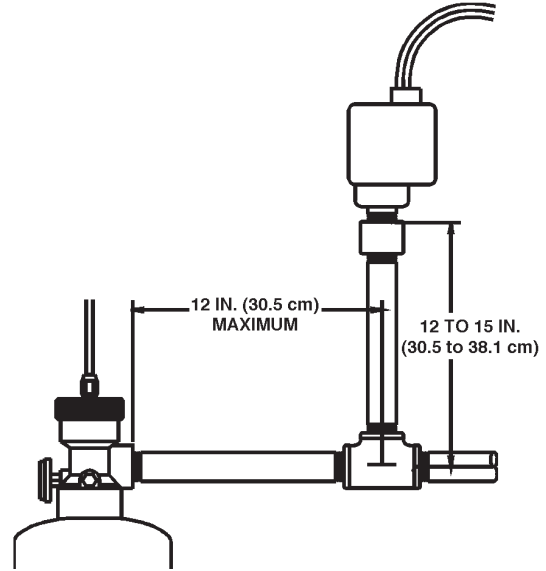

Figure 2-23. Pressure Switch Piping.

003025PC

PRESSURE BLEED DOWN ADAPTOR ASSEMBLY

The Pressure Bleed Down Adaptor Assembly, Part No. 551736, is required to open the valve stem on the tank when bleeding the tank down for six-year maintenance. See Figure 2-24.

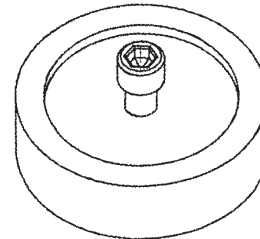

Figure 2-24. Pressure Bleed Down Adaptor Assembly.

004265

FLOW RESTRICTOR

A Model FR-25sBC flow restrictor is required to be placed directly before each Model N-LA-BC nozzle when used with the PCI-25sBC system for local overhead applications at any of the allowable nozzle heights. See Figure 2-25.

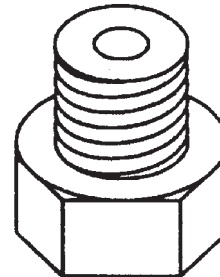

Figure 2-25. Model FR-25sBC Flow Restrictor

002862PC

**COMPONENT LIST
GENERAL PURPOSE SYSTEM**

MODEL NO.	DESCRIPTION	PART NO.
PCI-15ABC	15 lb ABC Cylinder and Valve Assembly	550388
PCI-17ABC	17 lb ABC Cylinder and Valve Assembly	551654
PCI-25sBC	25 lb BC Cylinder and Valve Assembly	550391
PCI-25sABC	25 lb ABC Cylinder and Valve Assembly	550390
PCI-35ABC	35 lb ABC Cylinder and Valve Assembly	551097
PCI-50sBC	50 lb BC Cylinder and Valve Assembly	550393
PCI-50sABC	50 lb ABC Cylinder and Valve Assembly	550392
PCI-70ABC	70 lb ABC Cylinder and Valve Assembly	551094
PAC-10	Pneumatic Actuating Cylinder	550104
PAC-200	Pneumatic Actuating Cylinder	550690
MB-P2	Control Head Mounting Bracket	550853
MB-15	Mounting Bracket (PCI-15,17,25s Cylinders)	550054
MB-1	Mounting Bracket (PCI-35,70 Cylinders)	550053
▶ MB-U8	8 in. Channel-Type Mounting Bracket	550324
MB-U10	10 in. Channel-Type Mounting Bracket	550383
▶ MB-U12	12 in. Channel-Type Mounting Bracket	550638
MCH3	Mechanical Control Head	551200
NMCH3	Mechanical Control Head	551203
ECH3-24	24VDC Electrical Control Head	551201
ECH3-120	120VDC Electrical Control Head	551202
- - -	8 in. S.S. Actuation Hose	417582
- - -	16 in. S.S. Actuation Hose	31809
- - -	24 in. S.S. Actuation Hose	32336
- - -	42 in. S.S. Actuation Hose	430815
- - -	Male Elbow	31810
- - -	Male Tee	31811
- - -	Male Straight Connector	32338
PDA-D2	Pneumatic Actuating Adaptor	550829
- - -	Swing Check Valve	417788
NF-ABC	Nozzle Assembly	551678
N-LA-ABC	Nozzle Assembly	550646
N-LA-BC	Nozzle Assembly	550342
N-TS	Nozzle Assembly	550337
RPS-M	Remote Mechanical Pull Station	551074
RPS-E2	Remote Electric Pull Station	551166
FKL-1	10 in. Fusible Link Bracket	550131
FKL-1A	8 in. Fusible Link Bracket	550132
FLH-25	Fusible Link Hanger (25)	550876
FL-165	165° F Fusible Link	550368
FL-212	212° F Fusible Link	550365
FL-280	280° F Fusible Link	550366
FL-360	360° F Fusible Link	550009
FL-450	450° F Fusible Link	550367
FL-500	500° F Fusible Link	56816
SM-24	24VDC Solenoid Monitor	550303
▶ SM-120	120VAC Solenoid Monitor	550302
TD-190	190° F Thermal Detector	13970
TD-225	225° F Thermal Detector	13976
TD-325	325° F Thermal Detector	13975
TD-450	450° F Thermal Detector	13974
▶ TD-600	600° F Thermal Detector	13971
GV-75	3/4 in. Mechanical Gas Valve	550593
GV-100	1 in. Mechanical Gas Valve	550594

COMPONENT LIST
GENERAL PURPOSE SYSTEM (Continued)

MODEL NO.	DESCRIPTION	PART NO.
▶ GV-125	1 1/4 in. Mechanical Gas Valve	550595
GV-150	1 1/2 in. Mechanical Gas Valve	550596
GV-200	2 in. Mechanical Gas Valve	551049
GV-250	2 1/2 in. Mechanical Gas Valve	550185
GV-300	3 in. Mechanical Gas Valve	550186
EGVSO-75	3/4 in. Electric Gas Valve	550358
EGVSO-100	1 in. Electric Gas Valve	550359
EGVSO-125	1 1/4 in. Electric Gas Valve	550360
EGVSO-150	1 1/2 in. Electric Gas Valve	550361
EGVSO-200	2 in. Electric Gas Valve	550362
EGVSO-250	2 1/2 in. Electric Gas Valve	550363
▶ EGVSO-300	3 in. Electric Gas Valve	550385
MS-SPDT	Micro-Switch – Single Pole Double Throw	551154
MS-DPDT	Micro-Switch – Double Pole Double Throw	551155
MS-3PDT	Micro-Switch – 3 Pole Double Throw	551156
MS-4PDT	Micro-Switch – 4 Pole Double Throw	551157
▶ – – –	Alarm Initiating Switch	550077
PS-SPDT-XP	Pressure Switch – Single Pole Double Throw	550052
CO2-6	6 x CO ₂ Cartridge	551059
CBP-1	Compression Bearing Corner Pulley	423250
SBP-1	Screw Bearing Corner Pulley	415670
▶ WBP-1	Weather Proof Corner Pulley (10 Per Package)	550983
TP-1	Tee Pulley	550166
▶ WC-100	Oval Sleeve Crimps (100 Per Package)	550122
– – –	Stop Sleeves (Pack of 10)	24919
– – –	Valve – Piston O-Ring	550636
– – –	Valve – Stem Washer	550284
– – –	Valve – Seat Washer	550021
– – –	Valve – Stem Head	550020
– – –	Valve – Body O-Ring	550029
– – –	Valve – Pressure Gauge	550025
– – –	Valve – Stem	550806
– – –	Valve – Stem O-Ring	550028
– – –	Valve – Conical Spring	550022
▶ – – –	Valve – Piston	550805
FR-25sBC	Flow Restrictor	550235
▶ – – –	Pressure Bleed Down Adaptor Assembly	551736
– – –	Dry Valve Rebuilding Kit	550037
– – –	Recharge Adaptor	550130
▶ – – –	Dry Valve Hydrotest Adaptor	552182

CHAPTER III SYSTEM DESIGN

General

PYRO-CHEM Industrial Fire Suppression Systems may be used on a variety of hazards in many types of applications. The guidelines listed in this chapter deal with the limitations and parameters of various system configurations. It is the responsibility of the Certified installer to ensure that the proper system is being utilized, and that the system meets the limitations and parameters listed in this chapter. Before attempting to design any system it is necessary to attend a Factory Certification Training Class and become Certified to install PYRO-CHEM Industrial Fire Suppression Systems.

Choosing the Proper Agent

It is necessary for the system designer to consider the combustible material found in the hazard area to ensure proper protection. The agent used in the system must be approved for the hazard class of the combustible material. The following are the hazard classes:

“A” Class – Ordinary solid carbonaceous combustibles. These include wood, paper, cloth, fiberglass, and plastics

“B” Class – Flammable liquids and gases. These include paints, solvents, gasoline, oils, and hydraulic fluids.

“C” Class – Electrical appliances. These include computers, power generators, and power transformers.

“D” Class – Combustible metals such as sodium, potassium, magnesium, titanium, and zirconium. The PYRO-CHEM Industrial Fire Suppression System is not intended to protect Class D hazards.

The following guidelines should be used for determining the proper agent:

ABC (monoammonium phosphate-based) – for use with all “A,” “B,” and “C” Class hazards.

BC (sodium bicarbonate-based) – for use with “B” and “C” Class hazards.

As per NFPA 17, pre-engineered dry chemical systems are not approved for deep-seated or burrowing fires (such as ordinary combustibles where the agent cannot reach the point of combustion), or on chemicals that contain their own oxygen supply (such as cellulose nitrate). Do not mix different types of agents, or agents from different manufacturers. Chemical reactions may occur when incompatible chemicals are mixed. **Keep in mind that the agent used for each system must be acceptable to the Authority Having Jurisdiction.**

Choosing the Proper Type of System

It is necessary for the system designer to consider the physical characteristics and layout of the hazard area to ensure proper protection. The hazard area must meet the criteria for a particular system for that system to be effective. The hazard area must be protected in accordance with NFPA 17 for proper protection. The following are lists of system types and the guidelines that are used to determine the proper type of system for that hazard:

System Types

Local Application – Tankside – A supply of dry chemical agent is discharged directly onto a fire through an arrangement of discharge nozzles. This system is used for applying agent across a hazard area from the side of the area. Typical applications include but are not limited to dip tanks, quench tanks, and solvent tanks where overhead obstructions are present. Tankside applications require that the liquid tank have at least 4 in. of freeboard space above the liquid surface.

Tankside local application systems can utilize either BC (sodium bicarbonate-based) or ABC (monoammonium phosphate-based) suppression chemical.

BC (sodium bicarbonate-based) chemical is utilized to suppress fires of “B” class combustible material (flammable liquids). Class C protection only acceptable if total flooding.

ABC (monoammonium phosphate-based) chemical is utilized to suppress fires of “A” class combustible material (ordinary solid carbonaceous combustibles), “B” class combustible material (flammable liquids). Class C protection only acceptable if total flooding.

Local Application – Overhead – A supply of dry chemical agent is discharged directly onto a fire through an arrangement of discharge nozzles. This system is used for applying agent to an area from above the area. Typical applications include but are not limited to dip tanks, power generators, conveyors, belt driven machinery and transformers. The

- ▶ maximum nozzle height for overhead protection is 10 ft
- ▶ (3.0 m) for ABC coverage, and 11 ft (3.3 m) for BC coverage.

Overhead local application systems can utilize either BC (sodium bicarbonate-based) or ABC (monoammonium phosphate-based) suppression chemical.

BC (sodium bicarbonate-based) chemical is utilized to suppress fires of “B” class combustible material (flammable liquids).

ABC (monoammonium phosphate-based) chemical is utilized to suppress fires of “A” class combustible material (ordinary solid carbonaceous combustibles), “B” class combustible material (flammable liquids).

Total Flooding – A supply of dry chemical agent is discharged into an enclosure surrounding the hazard by an arrangement of discharge nozzles. This type of system is used where there is a permanent enclosure surrounding the hazard that adequately enables the required concentration of agent to be built up. Typical applications include but are not limited to hazardous storage containers, computer rooms, generator rooms, and warehouses where sprinkler protection is unavailable. Total flooding systems require that an enclosure be present around the hazard area to allow the system to build up the proper concentration of agent within the hazard area. All total flooding systems utilize ABC (monoammonium phosphate-based) chemical only. ABC (monoammonium phosphate-based) chemical is utilized to suppress fires of “A” class combustible material (ordinary solid carbonaceous combustibles), “B” class combustible material (flammable liquids) and “C” class combustible material (electrical).

Guidelines

Where an enclosure is suitable for allowing total flooding protection depends on the unclosable opening percentage of the enclosure. Unclosable opening percentage is calculated as the area of the opening divided by the total surface area of the enclosure (area of the sides, top, and bottom of the enclosure.).

1. Total Flood. 0-5% Unclosable Opening

Total flooding protection is qualified for use on hazards whose enclosure has up to 5% unclosable opening. For enclosures that have greater than 5% unclosable opening, screening is required.

NFPA 17, “Dry Chemical Extinguishing Systems,” makes an exception to the one pound of dry chemical per square foot of opening size not exceeding 15% of the total volume surface area which reads “a system that is listed by a testing laboratory for or including protection of unclosable openings may be used in lieu of the above.”

1a. Total Flood. Greater than 5% Unclosable Opening

This system can utilize the N-OTF total flood nozzle(s) and the N-SCR screening nozzle(s). The design is approved to a maximum hazard height of 12 ft (3.6 m) with no maximum unclosable opening.

a. Cylinders:

The Models PCI-15ABC, PCI-25sABC, PCI-35ABC, PCI-50sABC, and PCI-70ABC cylinders can be used for total flood greater than 5% unclosable opening.

b. Nozzles:

Four nozzles are available:

<u>Nozzle</u>	<u>Application</u>
N-SCR	Screening the opening
N-OTF	Work Area (Overhead Position)
N-PLU	Plenum Area (Overhead Position)
N-DCT	Duct

c. Temperature Range:

The operating temperature range is 32 °F to 120 °F (0 °C to 48 °C).

2. Local Application Tankside. (Indoor Use Only)

a. Cylinders:

The Models PCI-25sBC, PCI-25sABC, PCI-50sBC, and PCI-50sABC can be used for tankside applications.

b. Nozzles:

The Model N-TS nozzle is used for all tankside applications.

c. Temperature Range:

The operating temperature range for the dry chemical cylinder assembly used for tankside applications is -20° F. to 120° F. (-28° C. to 48° C.).

d. Piping Requirements:

When using the Model PCI-25sBC or PCI-50sBC systems, each nozzle protects a maximum of 36 square feet with a maximum side dimension of 6 feet.

When using the Model PCI-25sABC or PCI-50sABC systems, each nozzle protects a maximum of 20.25 square feet with a maximum side dimension of 4 feet 6 inches.

The Model N-TS nozzle must be mounted 3 in. to 8 in. above the liquid surface, at least 1 in. below the lip of the pan. See **Figure 3-1**.

e. Piping Requirements:

Piping diagrams below include limitations on pipe length and fittings.

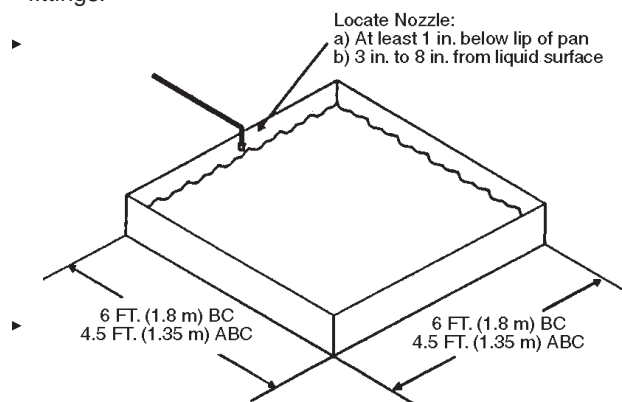
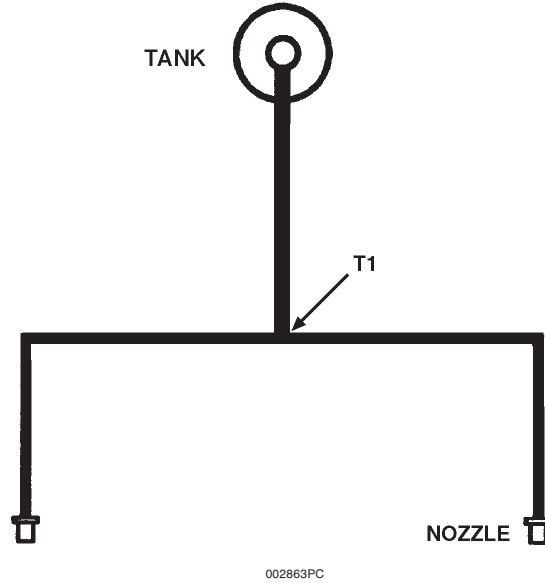

Figure 3-1. N-TS Nozzle Location

003034PC

PCI-25sABC with 2 nozzles



Tankside Piping Limits PCI-25sABC

Cylinder Size	Maximum Nozzle Quantity	Nozzle Type	Piping Section	Size	Length Maximum	Elbows Maximum	Length Minimum	Elbows Minimum
PCI-25sABC	2	N-TS	Cylinder to T1	3/4 in.	31 ft (9.5 m)	6	5 ft (1.5 m)	1
			T1 to Nozzle	3/4 in.	16 ft (4.9 m)	4	3 ft (0.9 m)	1
			Total Cylinder to Nozzle		47 ft (14.3 m)	10	20 ft (6.1 m)	4

Tankside Piping Limits PCI-25sBC

Cylinder Size	Maximum Nozzle Quantity	Nozzle Type	Piping Section	Size	Length Maximum	Elbows Maximum	Length Minimum	Elbows Minimum
PCI-25sBC	2	N-TS	Cylinder to T1	3/4 in.	28 ft (8.5 m)	6	5 ft (1.5 m)	1
			T1 to Nozzle	3/4 in.	25 ft (7.6 m)	4	3 ft (0.9 m)	1
			Total Cylinder to Nozzle		53 ft (16.2 m)	10	25 ft (7.6 m)	4

NOTE:

1. PCI-25sABC/BC must always use two (2) N-TS nozzles.
2. System piping must be balanced. Balanced piping is that in which the difference between the shortest actual pipe length from T1 to nozzle and the longest actual pipe length from T1 to nozzle does not exceed 10% of the longest actual pipe length from T1 to nozzle. The number and type of fittings from all last tee to nozzle sections must be equal.
3. A Main/Reserve Swing Check Valve, Part No. 417788, may be located between the cylinder and T1.

PCI-50sABC/BC with 4 Nozzles

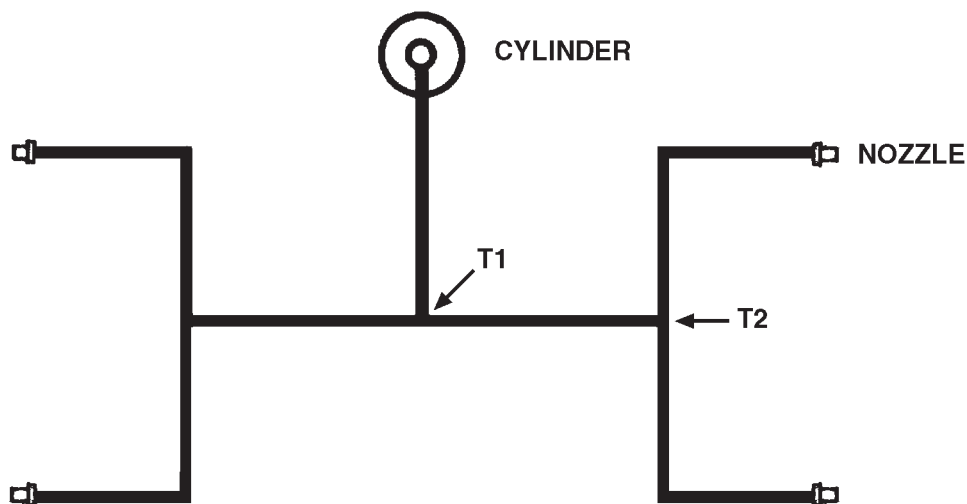

003020PC

Tankside Piping Limits PCI-50sABC

Cylinder Size	Maximum Nozzle Quantity	Nozzle Type	Piping Section	Size	Length Maximum	Elbows Maximum	Length Minimum	Elbows Minimum
PCI-50sABC	4	N-TS	Cylinder to T1	1 in.	53 ft (16.2 m)	6	6 ft (1.8 m)	1
			T1 to T2	3/4 in.	6 ft (1.8 m)	2	2 ft (0.6 m)	1
			T2 to Nozzle	3/4 in.	6 ft (1.8 m)	4	2 ft (0.6 m)	1
			Total Cylinder to Nozzle		65 ft (19.8 m)	10	16 ft (4.9 m)	4

Tankside Piping Limits PCI-50sBC

Cylinder Size	Maximum Nozzle Quantity	Nozzle Type	Piping Section	Size	Length Maximum	Elbows Maximum	Length Minimum	Elbows Minimum
PCI-50sBC	4	N-TS	Cylinder to T1	1 in.	65 ft (19.8 m)	8	5 ft (1.5 m)	2
			T1 to T2	3/4 in.	15 ft (4.6 m)	4	2 ft (0.6 m)	0
			T2 to Nozzle	3/4 in.	15 ft (4.6 m)	4	2 ft (.6 m)	1
			Total Cylinder to Nozzle		95 ft (29 m)	14	16 ft (4.9 m)	3

NOTE:

1. PCI-50sABC/BC must always use four (4) N-TS nozzles.
2. System piping must be balanced. Balanced piping is that in which the difference between the shortest actual pipe length from T1 to nozzle and the longest actual pipe length from T1 to nozzle does not exceed 10% of the longest actual pipe length from T1 to nozzle. T2 to nozzle on the same branch must not exceed 10% of each other. The number and type of fittings from all last tee to nozzle sections must be equal.
3. A Main/Reserve Swing Check Valve, Part No. 417788, may be located between the cylinder and T1.
4. Minimum requirements for piping and fittings do not apply to systems protecting hazards with no splashable hazard. A splashable hazard exists where liquid fuel in depth greater than 1/4 in. is present.

3. Local Application Overhead. (Indoor Use Only)

a. Cylinders:

The Model PCI-25sBC, PCI-25sABC, PCI-50sBC, and PCI-50sABC can be used for local overhead applications.

b. Nozzles:

The Model N-LA-ABC nozzle is used for both the PCI-25sABC and PCI-50sABC systems. The maximum nozzle height of the Model N-LA-ABC nozzle is 10 feet. The minimum nozzle height of the Model N-LA-ABC nozzle is 7.5 feet.

The Model N-LA-BC nozzle is used for both the PCI-25sBC and PCI-50sBC systems. The maximum nozzle height of the Model N-LA-BC nozzle is 11 feet. The minimum nozzle height of the Model N-LA-BC nozzle is 7.5 feet.

Note: Nozzle height is measured from the hazard surface to the closest point of the nozzle in the installed position.

c. Flow Restrictor:

A Model FR-25sBC flow restrictor is required to be placed directly before each Model N-LA-BC nozzle when used with the PCI-25sBC system for local overhead applications at any of the allowable nozzle heights. **See Figure 3-2.** No flow restrictors are required for PCI-25sABC, PCI-50sABC, or PCI-50sBC systems.

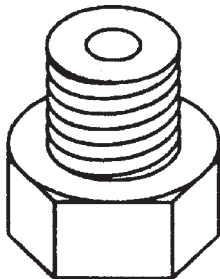

Figure 3-2. Model FR-25sBC Flow Restrictor

002862PC

d. Temperature Range:

The operating temperature range for the dry chemical cylinder assembly used for local overhead applications is 32 °F to 120 °F (0 °C to 48 °C).

e. Piping Requirements:

Piping diagrams include limitations on pipe length and fittings.

Note: All listed piping diagrams represent maximum number of nozzles allowed. In applications that do not require the maximum number of nozzles, the quantity of nozzles can be reduced.

In applications of this type, along with the already listed limitations (notes included with each maximum layout), the following limitations apply:

- On the reduced nozzle side of the piping layout, the largest listed size pipe on the standard configuration layout must be utilized from T1 to nozzle.
- The maximum length of the reduced nozzle side must be the original combination from T1 to T2, and T2 to nozzle. **Note:** In systems utilizing a T3 split, the maximum length of the reduced nozzle side must be the original combination from T1 to T2, T2 to T3, and T3 to nozzle.
- The maximum number of elbows must be the original combination from T1 to T2, and T2 to nozzle. **Note:** In systems utilizing a T3 split, the maximum number of elbows must be the original combination from T1 to T2, T2 to T3, and T3 to nozzle.

f. Nozzle Placement and Coverage:

The Models N-LA-ABC and N-LA-BC nozzles have been developed to provide local application of extinguishing agent from an overhead position. Both nozzles will protect a hazard area of 25 sq ft with a 5 foot maximum side. Proper nozzle placement is shown in **Figure 3-3.**

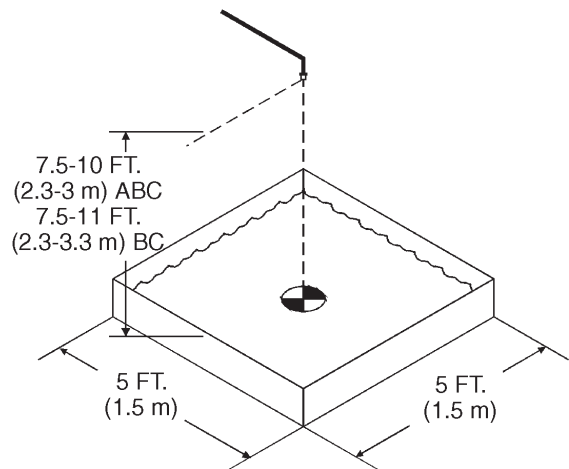
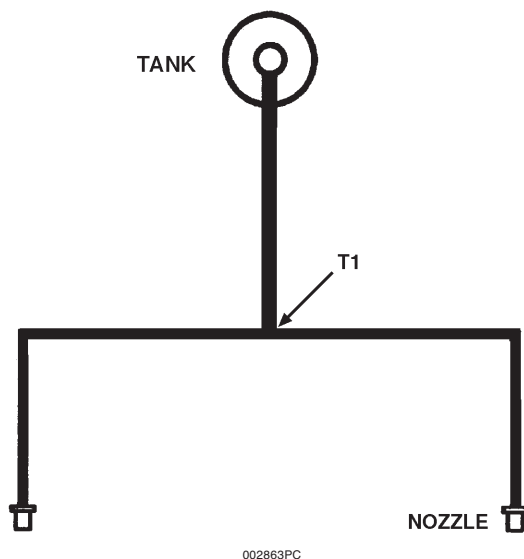

Figure 3-3. Nozzle Placement for Local Overhead Application.

003029PC

Note: Minimum nozzle height of 7.5 ft (2.3 m) is only required when splashable liquid of 1/4 in. or greater is located in the hazard area.

PCI-25sABC/BC with 2 Nozzles



Local Overhead Application Piping Limits PCI-25sABC

Cylinder Size	Maximum Nozzle Quantity	Nozzle Type	Piping Section	Size	Length Maximum	Elbows Maximum	Length Minimum	Elbows Minimum
PCI-25sABC	2	N-LA-ABC	Cylinder to T1	3/4 in.	28 ft (8.5 m)	5	5 ft (1.5 m)	1
			T1 to Nozzle	3/4 in.	25 ft (7.6 m)	4	2.5 ft (0.8 m)	1
			Total Cylinder to Nozzle		53 ft (16.2 m)	9	25 ft (7.6 m)	4

Local Overhead Application Piping Limits PCI-25sBC

Cylinder Size	Maximum Nozzle Quantity	Nozzle Type	Piping Section	Size	Length Maximum	Elbows Maximum	Length Minimum	Elbows Minimum
PCI-25sBC	2	N-LA-BC	Cylinder to T1	3/4 in.	35 ft (10.7 m)	4	12.5 ft (3.8 m)	1
			T1 to Nozzle	3/4 in.	12 ft (3.7 m)	3	2.5 ft (0.8 m)	1
			Total Cylinder to Nozzle		47 ft (14.3 m)	7	24.5 ft (7.5 m)	4

NOTE:

1. PCI-25sABC must always use two (2) N-LA-ABC nozzles.
2. PCI-25sBC must always use two (2) N-LA-BC nozzles.
3. System piping must be balanced. Balanced piping is that in which the difference between the shortest actual pipe length from T1 to nozzle and the longest actual pipe length from T1 to nozzle does not exceed 10% of the longest actual pipe length from T1 to nozzle. The number and type of fittings from all last tee to nozzle sections must be equal.
4. A Main/Reserve Swing Check Valve, Part No. 417788, may be located between the cylinder and T1.
5. Minimum requirements for piping and fittings do not apply to systems protecting hazards with no splashable hazard. A splashable hazard exists where liquid fuel in depth greater than 1/4 in. is present.

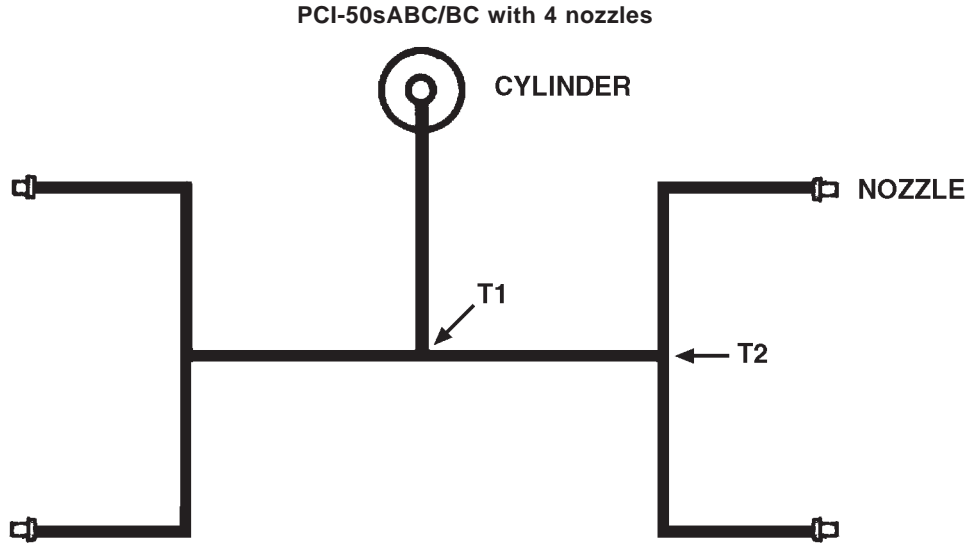

003020PC

Local Overhead Piping Limits PCI-50sABC

Cylinder Size	Maximum Nozzle Quantity	Nozzle Type	Piping Section	Size	Length Maximum	Elbows Maximum	Length Minimum	Elbows Minimum
PCI-50sABC	4	N-LA-ABC	Cylinder to T1	1 in.	25 ft (7.6 m)	4	5 ft (1.5 m)	1
			T1 to T2	3/4 in.	10 ft (3.1 m)	2	2.5 ft (0.8 m)	0
			T2 to Nozzle	3/4 in.	8 ft (2.4 m)	2	2.5 ft (.8 m)	1
			Total Cylinder to Nozzle		43 ft (13.1 m)	8	20 ft (6.1 m)	3

Local Overhead Application Piping Limits PCI-50sBC

Cylinder Size	Maximum Nozzle Quantity	Nozzle Type	Piping Section	Size	Length Maximum	Elbows Maximum	Length Minimum	Elbows Minimum
PCI-50sBC	4	N-LA-BC	Cylinder to T1	1 in.	35 ft (10.7 m)	4	15.5 ft (4.7 m)	1
			T1 to T2	3/4 in.	12 ft (3.7 m)	2	2.5 ft (0.8 m)	0
			T2 to Nozzle	3/4 in.	12 ft (3.7 m)	3	2.5 ft (.8 m)	1
			Total Cylinder to Nozzle		59 ft (18 m)	9	30 ft (9.1 m)	4

NOTE:

1. PCI-50sABC must always use four (4) N-LA-ABC nozzles.
2. PCI-50sBC must always use four (4) N-LA-BC nozzles.
3. System piping must be balanced. Balanced piping is that in which the difference between the shortest actual pipe length from T1 to nozzle and the longest actual pipe length from T1 to nozzle does not exceed 10% of the longest actual pipe length from T1 to nozzle. T2 to nozzle on the same branch must not exceed 10% of each other. The number and type of fittings from all last tee to nozzle sections must be equal.
4. A Main/Reserve Swing Check Valve, Part No. 417788, may be located between the cylinder and T1.
5. Minimum requirements for piping and fittings do not apply to systems protecting hazards with no splashable hazard. A splashable hazard exists where liquid fuel in depth greater than 1/4 in. is present.

4. Total Flooding with ABC

a. Cylinders:

The Models PCI-17ABC, PCI-35ABC, and PCI-70ABC cylinders can be used for ABC total flooding applications.

b. Nozzles:

The Model NF-ABC is used for all ABC total flooding applications.

The Model PCI-17ABC can support one (1) Model NF-ABC nozzle.

The Model PCI-35ABC can support two (2) Model NF-ABC nozzles.

The Model PCI-70ABC can support four (4) Model NF-ABC nozzles.

c. Temperature Ranges:

The operating temperature range for ABC total flooding applications is $-20\text{ }^{\circ}\text{F}$ to $120\text{ }^{\circ}\text{F}$ ($-28\text{ }^{\circ}\text{C}$ to $48\text{ }^{\circ}\text{C}$).

d. Piping Requirements:

Piping diagrams include limitations on pipe length and fittings.

e. Nozzle

The nozzle is to be mounted in the center of the protected area, with the discharge holes in the nozzle no greater than six (6) inches from the ceiling. See Figure 3-4.

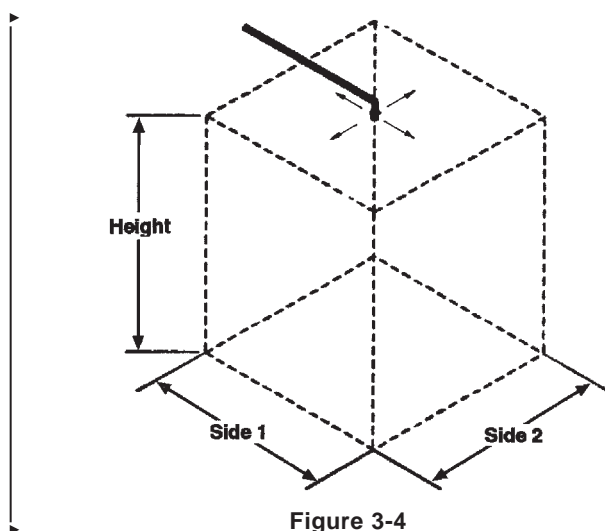

Figure 3-4

002866PC

f. Nozzle Coverages:

Protection	Nozzle	Specifications Maximum	Nozzle Location Within Protection Zone Length-Width-Height	Nozzle Offset	Nozzle Orientation
Flooding Area	NF-ABC	Volume – 1296 cu ft See Table 3-1	Length-Center Width-Center Height-20 ft maximum	0 – 6 in.	Vertical
Flooding Area	N-OTF	Volume – 768 cu ft 8 x 8 x 12 ft	Length-Center Width-Center Height-12 ft maximum	0 – 6 in.	Vertical
Screen Area	N-SCR	8 x 12 ft	Length-Center Width-Center Height-12 ft maximum	0 – 6 in.	Vertical

TABLE 3-1
Total Flooding Nozzle Protection Chart

Maximum Dimensions in feet/nozzle for one (1) Model NF-ABC

Side 1 (ft)	Nozzle Height (ft)	Maximum Side 2 (ft)	Side 1 (ft)	Nozzle Height (ft)	Maximum Side 2 (ft)	Side 1 (ft)	Nozzle Height (ft)	Maximum Side 2 (ft)	Side 1 (ft)	Nozzle Height (ft)	Maximum Side 2 (ft)
3	8	16.70	7	8	15.46	11	8	12.92	15	8	7.94
	9	16.70		9	15.46		9	12.92		9	7.94
	10	16.70		10	15.46		10	11.78		10	7.94
	11	16.70		11	15.46		11	10.71		11	7.85
	12	16.70		12	15.43		12	9.82		12	7.20
	13	16.70		13	14.24		13	9.06		13	6.65
	14	16.70		14	13.22		14	8.42		14	6.17
	15	16.70		15	12.34		15	7.85		15	5.76
	16	16.70		16	11.57		16	7.36		16	5.40
	17	16.70		17	10.89		17	6.93		17	5.08
	18	16.70		18	10.29		18	6.55		18	4.80
19	16.70	19	9.74	19	6.20	19	4.55				
20	16.70	20	9.26	20	5.89	20	4.32				
4	8	16.49	8	8	14.97	12	8	12.00	16	8	5.66
	9	16.49		9	14.97		9	12.00		9	5.66
	10	16.49		10	14.97		10	10.80		10	5.66
	11	16.49		11	14.73		11	9.82		11	5.66
	12	16.49		12	13.50		12	9.00		12	5.66
	13	16.49		13	12.46		13	8.31		13	5.66
	14	16.49		14	11.57		14	7.71		14	5.66
	15	16.49		15	10.80		15	7.20		15	5.40
	16	16.49		16	10.13		16	6.75		16	5.06
	17	16.49		17	9.53		17	6.35		17	4.76
	18	16.49		18	9.00		18	6.00		18	4.50
19	16.49	19	8.53	19	5.68	19	4.26				
20	16.20	20	8.10	20	5.40	20	4.05				
5	8	16.22	9	8	14.39	13	8	10.91			
	9	16.22		9	14.39		9	10.91			
	10	16.22		10	14.39		10	9.97			
	11	16.22		11	13.09		11	9.06			
	12	16.22		12	12.00		12	8.31			
	13	16.22		13	11.08		13	7.67			
	14	16.22		14	10.29		14	7.12			
	15	16.22		15	9.60		15	6.65			
	16	16.20		16	9.00		16	6.23			
	17	15.25		17	8.47		17	5.86			
	18	14.40		18	8.00		18	5.54			
19	13.64	19	7.58	19	5.25						
20	12.96	20	7.20	20	4.98						
6	8	15.87	10	8	13.71	14	8	9.59			
	9	15.87		9	13.71		9	9.59			
	10	15.87		10	12.96		10	9.26			
	11	15.87		11	11.78		11	8.42			
	12	15.87		12	10.80		12	7.71			
	13	15.87		13	9.97		13	7.12			
	14	15.43		14	9.26		14	6.61			
	15	14.40		15	8.64		15	6.17			
	16	13.50		16	8.10		16	5.79			
	17	12.71		17	7.62		17	5.45			
	18	12.00		18	7.20		18	5.14			
19	11.37	19	6.82	19	4.87						
20	10.80	20	6.48	20	4.63						

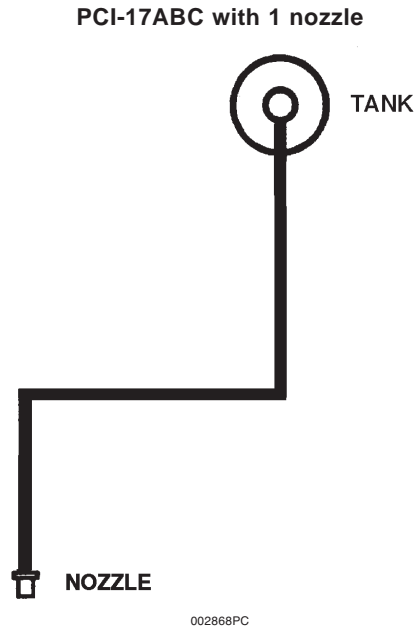

Total Flooding Piping Limits PCI-17ABC

Cylinder Size	Nozzle Quantity	Nozzle Type	Piping Section	Size	Length Maximum	Elbows Maximum
▶ PCI-17ABC	1	NF-ABC	Cylinder to Nozzle	3/4 in.	30 ft	4

NOTE:

1. PCI-17ABC uses one (1) NF-ABC nozzle.
- ▶ 2. A Main/Reserve Swing Check Valve, Part No. 417788, may be located between the cylinder and T1.

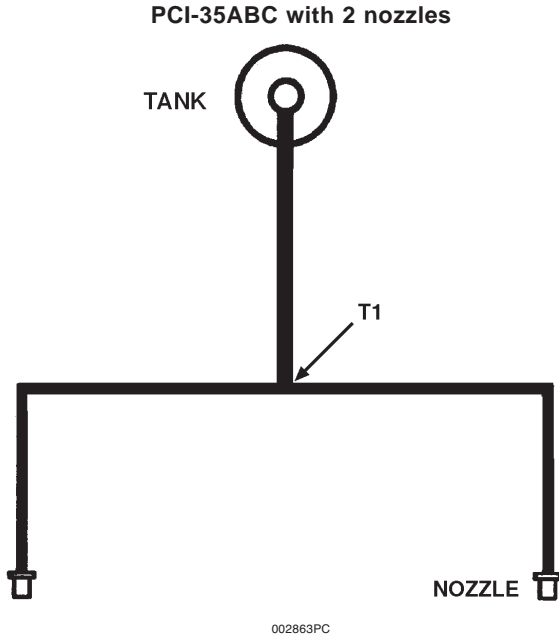

Total Flooding Piping Limits PCI-35ABC

Cylinder Size	Maximum Nozzle Quantity	Nozzle Type	Piping Section	Size	Length Maximum	Elbows Maximum
PCI-35ABC	2	NF-ABC	Cylinder to T1	3/4 in.	30 ft (9.1 m)	4
			T1 to Nozzle	3/4 in.	9 ft (2.7 m)	2

NOTE:

1. PCI-35ABC must always use two (2) NF-ABC nozzles.
2. System piping must be balanced. Balanced piping is that in which the difference between the shortest actual pipe length from T1 to nozzle and the longest actual pipe length from T1 to nozzle does not exceed 10% of the longest actual pipe length from T1 to nozzle. The number and type of fittings from all last tee to nozzle sections must be equal.
3. A Main/Reserve Swing Check Valve, Part No. 417788, may be located between the cylinder and T1.

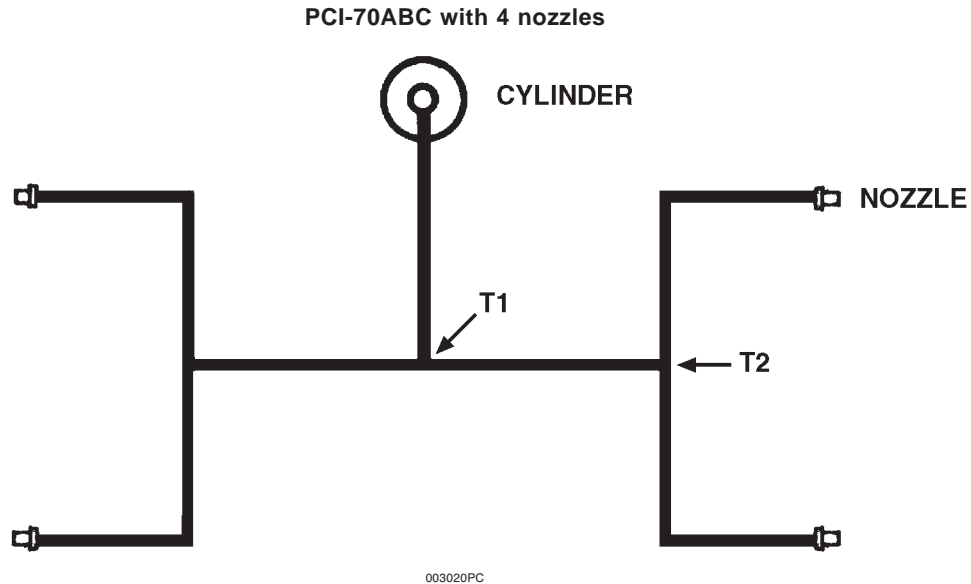

Total Flooding Piping Limits PCI-70ABC

Cylinder Size	Maximum Nozzle Quantity	Nozzle Type	Piping Section	Size	Length Maximum	Elbows Maximum
PCI-70ABC	4	NF-ABC	Cylinder to T1	1 in.	30 ft (9.1 m)	3
			T1 to T2	1 in.	14 ft (4.3 m)	2
			T2 to Nozzle	3/4 in.	9 ft (2.7 m)	2

NOTE:

1. PCI-70ABC must always use four (4) NF-ABC nozzles.
2. System piping must be balanced. Balanced piping is that in which the difference between the shortest actual pipe length from T1 to nozzle and the longest actual pipe length from T1 to nozzle does not exceed 10% of the longest actual pipe length from T1 to nozzle. T2 to nozzle on the same branch must not exceed 10% of each other. The number and type of fittings from all last tee to nozzle sections must be equal.
3. A Main/Reserve Swing Check Valve, Part No. 417788, may be located between the cylinder and T1.

PCI-70ABC with 6 nozzles

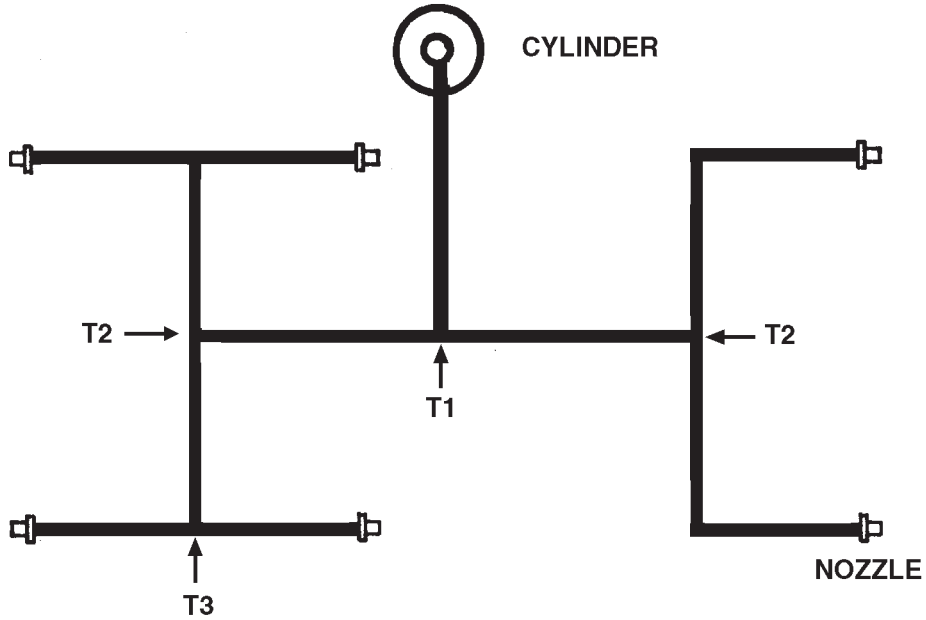

004937PC

Cylinder Size	Maximum Nozzle Quantity	Nozzle Type	Piping Section	Size	Length Maximum	Elbows Maximum
PCI-70ABC	6	N-SCR, N-OTF	Cylinder to T1	1 in.	18 ft (5.5 m)	3
			T1 to T2 (4 Nozzle Side)	1 in.	14 ft (4.3 m)	1
			T2 to T3	3/4 in.	4 ft (1.2 m)	0
			T3 to Nozzle	3/4 in.	6 ft (1.8 m)	2
			T1 to T2 (2 Nozzle Side)	1 in.	14 ft (4.3 m)	2
			T2 to Nozzle	3/4 in.	6 ft (1.8 m)	2

NOTE:

1. These limitations apply to PCI-70ABC using six nozzles (2-N-SCR, 4 N-OTF, or 6 N-OTF).
2. System piping must be balanced. Balanced piping is that in which the difference between the shortest actual pipe length from T1 to nozzle and the longest actual pipe length from T1 to nozzle does not exceed 10% of the longest actual pipe length from T1 to nozzle. T2 to nozzle on the same branch must not exceed 10% of each other. The number and type of fittings for all last tee to nozzle sections must be equal.
3. A Main/Reserve Swing Check Valve, Part No. 417788, may be located between the cylinder and T1.
4. When using the 2-N-SCR, 4-N-OTF nozzle combination, the 2-N-SCRs must be located on the two nozzle side of the piping layout.

Detector Placement.

Thermal detectors are required in all hazard areas protected by the PYRO-CHEM Industrial Fire Suppression Systems if automatic system operation is required. Either mechanical or electrical thermal detectors can be used for automatic system operation. Mechanical detectors (fusible links) are used in conjunction with the PYRO-CHEM Models MCH3 and NMCH3 control devices. Electrical detectors are used in conjunction with the PYRO-CHEM Models ECH3-24 and ECH3-120 Control Heads.

TOTAL FLOODING (DETECTOR SPACING) – THERMAL	
Ceiling Height	Spacing
Up to 14 ft (4.2 m) Height	15 ft (4.5 m) maximum between detectors 7 ft 6 in. (2.3 m) max. from wall 225 sq ft (20.9 sq m) max. coverage per detector
Greater than 14 ft (4.2 m) up to 20 ft (6.1 m) height	13 ft (3.9 m) maximum between detectors 6 ft 6 in. (1.9 m) max. from wall 169 sq ft (15.7 sq m) max. coverage per detector
Greater than 20 ft (6.9 m) up to 24 ft (7.3 m)	11 ft (3.4 m) max. between detectors 5 ft 6 in. (1.7 m) max. from wall 121 sq ft (11.2 sq m) max. coverage per detector
Greater than 24 ft (7.3 m) up to 30 ft (9.1 m)	9 ft (2.7 m) max. between detectors 4 ft 6 in. (1.4 m) max. from wall 81 sq ft (7.5 sq. m) max. coverage per detector

NOTE: For sloped ceiling (peaked type or shed type) installations, refer to NFPA-72, “National Fire Alarm Code” for detailed spacing requirements.

LOCAL APPLICATION – OVERHEAD (DETECTOR SPACING) – Maximum spacing per detector is 100 ft² (9.3 m²) or 5 ft (1.5 m) from edge of hazard and 10 ft (3.1 m) between detectors. When detectors are mounted below the ceiling in an open area, heat traps are recommended.

LOCAL APPLICATION – TANKSIDE (DETECTOR SPACING) – Detectors can be located either near the inner tank wall and flammable liquid surface or above the tank. If located above the tank, the rules for local application overhead would apply. If located on the tank wall, the detectors can be mounted horizontally or vertically in the freeboard area, but must be protected from damage during normal working operations. The maximum spacing per detector is 5 ft (1.5 m) from edge of hazard and 10 ft (3.1 m) between detectors.

A temperature survey must be performed to determine the maximum ambient temperature of the hazard survey. See Temperature Chart in Chapter 2 – Components.

TOTAL FLOODING (DETECTOR SPACING) – FUSIBLE LINKS	
Ceiling Height	Spacing
Up to 12 ft (3.66 m) Height	12 ft (3.66 m) maximum detectors 6 ft (1.83 m) max. from a wall* 144 sq ft (13.38 sq m) max. coverage per detector
Greater than 12 ft (3.66 m) up to 16 ft (4.88 m) height	10 ft (3.05 m) max. between detectors 5 ft (1.52 m) max. from wall 100 sq ft (9.29 sq m) max. coverage per detector
Greater than 16 ft (4.88 m) up to 20 ft (6.1 m) height	8 ft (2.44 m) max. between detectors 4 ft (1.22 m) max. from wall 64 sq ft (5.95 sq m) max. coverage per detector

Note: For sloped ceiling (peaked type or shed type) installations, refer to NFPA-72, “National Fire Alarm Code” for detailed spacing requirements.

LOCAL APPLICATION – OVERHEAD (DETECTOR SPACING) – Maximum spacing per fusible link detector is 36 ft² (3.3 m²) or 3 ft (0.9 m) from edge of hazard and 6 ft (1.8 m) between fusible link detectors.

When a detector(s) is mounted more than 1 ft (0.3 m) below ceiling or in an open area, heat trap(s) is recommended. Detectors should be mounted overhead at nozzle height or as close to the hazard as possible without interference, not to exceed 10 ft (3 m).

Detectors should not be located where they will be susceptible to damage during the normal work operation.

LOCAL APPLICATION – TANKSIDE (DETECTOR SPACING) – Detectors can be located either near the inner tank wall and flammable liquid surface or above the tank. If located above the tank, the rules for local application overhead would apply. If located on the tank wall, the detectors can be mounted horizontally or vertically in the freeboard area but must be protected from damage during normal working operation. Detectors should be located at a maximum spacing per detector of 3 ft (0.9 m) from edge of hazard and 6 ft (1.8 m) between detectors on the long side of the tank.

*For 14 ft (4.3 m) wide booths with maximum height of 12 ft (3.7 m), the detector location off the side wall can be a maximum of 7 ft (2.1 m), and 10 ft (3 m) maximum distance between detectors.

NOTES:

CHAPTER IV SYSTEM INSTALLATION

This chapter will detail the basic information necessary for proper installation of the PYRO-CHEM Industrial Fire Suppression System. However, before attempting any installation it is necessary to attend a Factory Certification Training Class and become Certified to install the PYRO-CHEM Industrial Fire Suppression System.

Pipe and fittings for the discharge piping, conduit (EMT), pipe straps, pipe hangers, mounting bolts, and other miscellaneous equipment are not furnished as part of the PYRO-CHEM Industrial Fire Suppression System. These items must be furnished by the installer.

Before attempting any installation, unpack the entire system and check that all necessary parts are on hand. Inspect parts for damage. Verify that cylinder pressure is within the acceptable range as shown on the gauge.

CYLINDER INSTALLATION

The cylinder and valve assembly is shipped with an anti-recoil plug in the valve discharge port.

CAUTION

The anti-recoil plug must remain in the valve discharge port until the discharge piping is connected to the valve.

The cylinder must be mounted vertically with the discharge port facing either left or right. The Models PCI-17 and PCI-25 cylinders must be mounted using a Model MB-15 Mounting Bracket Kit. The Model PCI-35, PCI-50, PCI-70, and PCI-cylinders must be mounted using a Model MB-1 Mounting Bracket Kit.

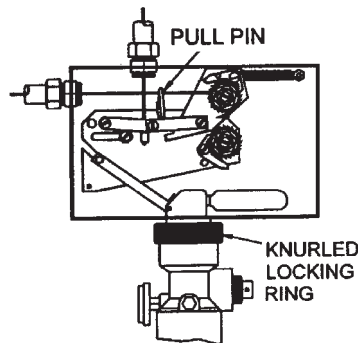

The bracket must be securely anchored to the wall using bolts or lag screws. The wall to which the bracket is attached must be sufficiently strong to support the cylinder. The bracket should never be fastened to dry wall or similar material. If this type of wall is encountered, studs must be located and the bracket fastened to them. See Figure 4-1.

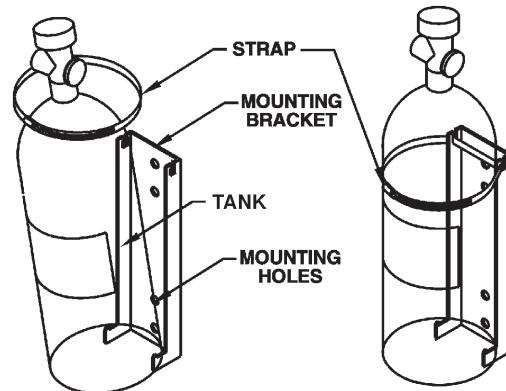

Figure 4-1. Cylinder and Mounting Bracket Installation.

002871PC

CONTROL HEAD INSTALLATION

1. Single Cylinder Installations.

For single cylinder system installations the Model MCH3/ECH3/NMCH3 Control Head can be installed directly onto the cylinder valve. When the control head is properly aligned in the desired position, tighten the knurled locking ring to secure the assembly. See Figure 4-2.

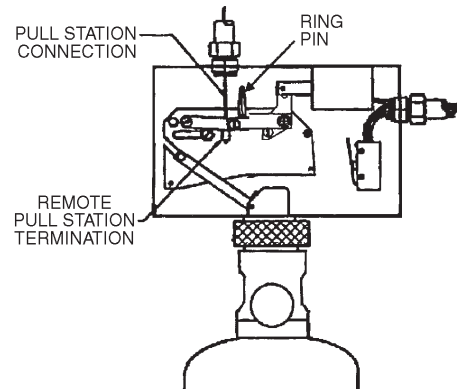

Figure 4-2. Single Cylinder Installation Using Model MCH3/ECH3/NMCH3 Control Head

002872PC/003647PC

2. Multiple Cylinder Installations.

A. Multiple Cylinder Actuation Using MCH3/ECH3/NMCH3 Control Head.

The Model MCH3/ECH3/NMCH3 Control Head can be used to pneumatically actuate a maximum of five (5) agent cylinders with a 16 gram CO₂ cartridge. When a control head is used for multiple cylinder actuation, it cannot be mounted directly onto a cylinder valve. The control head must be installed remotely using a Model MB-P2 Control Head Mounting Bracket. The bracket must be anchored to the wall using bolts or lag screws.

CAUTION

Do not screw the control head directly to a wall as this will warp the control head, not allowing the mechanism to actuate.

In order to actuate the agent cylinder(s) from a control head, a 1/4 in. NPT x 45° 1/4 in. flare type fitting (conforming to SAE J513c) or male straight connector (Part No. 32338) must be screwed into the base of the control head actuator. Also, a Model PDA-D2 Pneumatic Discharge Adaptor must be installed on the valve of each agent cylinder. Pneumatic tubing or stainless steel actuation hose is then used to connect the control head to the PDA-D2 of each agent cylinder valve. See Figure 4-3.

NOTE

Pneumatic tubing used for remote cylinder actuation shall have an outside diameter of 1/4 in. with a minimum wall thickness of 1/32 in. This is commonly known as refrigeration-type copper tubing. All tubing fittings shall be of the 1/4 in., 45° flare type conforming to SAE J513c. **Compression type fittings are not acceptable.**

A single Model MCH3/ECH3/NMCH3 Control Head can actuate:

1. Up to four (4) cylinders with a maximum of 25 ft (7.6 m) of copper or stainless steel pneumatic tubing or stainless steel actuation hose when using an O-ring (Part No. 55531) installed in place of the Teflon washer and the 16 gram CO₂ cartridge.
2. Up to five (5) cylinders with a maximum of 18 ft (5.4 m) of copper or stainless steel pneumatic tubing or stainless steel actuation hose when using an O-ring (Part No. 55531) installed in place of the Teflon washer and the 16 gram CO₂ cartridge.

CAUTION

Confirm the Teflon washer in the control head actuator assembly has been replaced with the O-ring (Part No. 55531) and the 16 gram CO₂ cartridge is installed for 4 and 5 cylinder single control head actuation.

The actuation line must be tested for any leaks by using a hand held or electric vacuum pump. The pump should be used to draw a vacuum on the actuation line at the fitting closest to the control head. A vacuum should be pulled to 20 inches of mercury. Leaks exceeding 5 inches of mercury within 30 seconds are not allowed. If the gauge on the vacuum pump indicates a leak in the line, examine the actuation line for loose fittings or damage. Correct any leaks and retest.

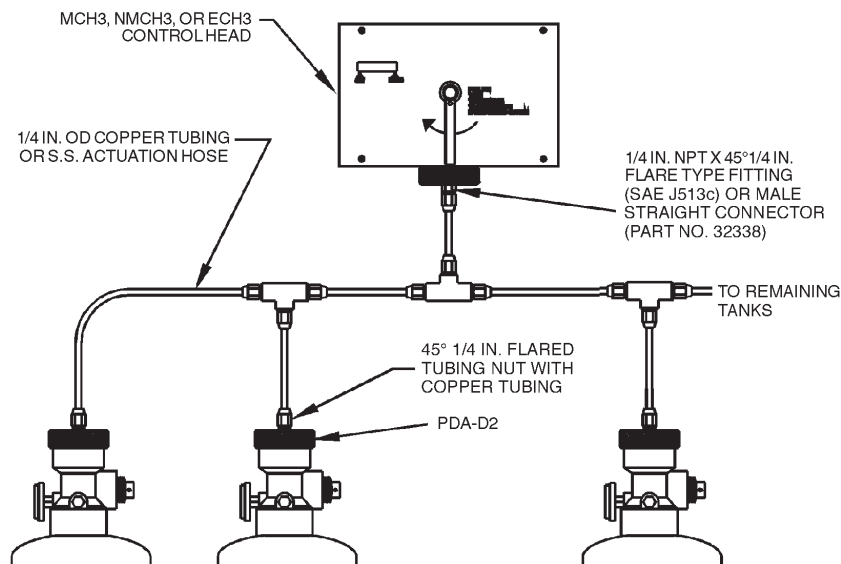

Figure 4-3. Multiple Cylinder Actuation Using Model MCH3/ECH3/NMCH3 Control Head

002873PC

B. Multiple Cylinder Actuation Using Model PAC-10 or PAC-200 Pneumatic Actuation Cylinder.

The Model PAC-10 or PAC-200 Pneumatic Actuation
 ▶ Cylinder must be used if more than five (5) agent cylinders require simultaneous actuation. The Model PAC-10/200 must be used in conjunction with a Model MCH3/ECH3/NMCH3 Control Head. The control head is mounted on the Model PAC-10/200 valve assembly.

The Model PAC-10/200 is shipped complete with a mounting bracket. The cylinder must be mounted vertically with the nameplate facing out. The bracket must be securely anchored to the wall using bolts or lag screws. The wall to which the bracket is attached must be sufficiently strong to support the pneumatic cylinder. The bracket should never be fastened to dry wall or similar material. If this type of wall is encountered, studs must be located and the bracket fastened to them. **See Figure 4-4.**

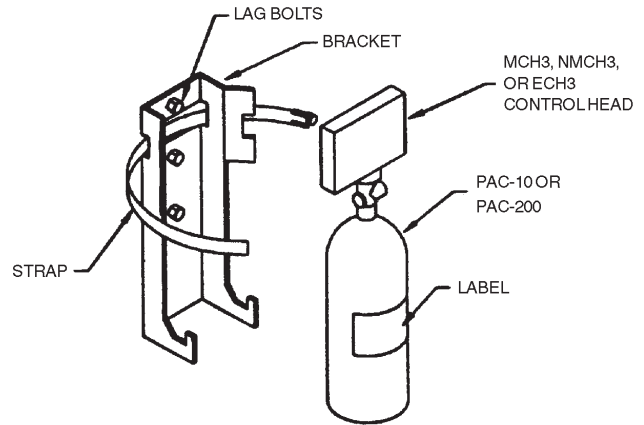

Figure 4-4. Model PAC-10/200 Pneumatic Cylinder Installation

002874PC

In order to actuate the agent cylinders from a Model PAC-
 ▶ 10/200 Pneumatic Actuation Cylinder, a 3/4 in. NPT x 1/4 in. NPT bushing must be screwed into the pneumatic cylinder's
 ▶ discharge port. A 1/4 in. NPT x 45° 1/4 in. flare type fitting (conforming to SAE J513c) must then be screwed into this
 ▶ bushing. The male straight connector (Part No. 32338) is
 ▶ used with stainless steel actuation hose. Also, a Model PDA-D2 Pneumatic Discharge Adaptor must be installed on the valve of each agent cylinder. Pneumatic tubing is then used to connect the PAC-10/200 pneumatic cylinder to the PDA-D2 of each agent cylinder valve. **See Figure 4-5.**

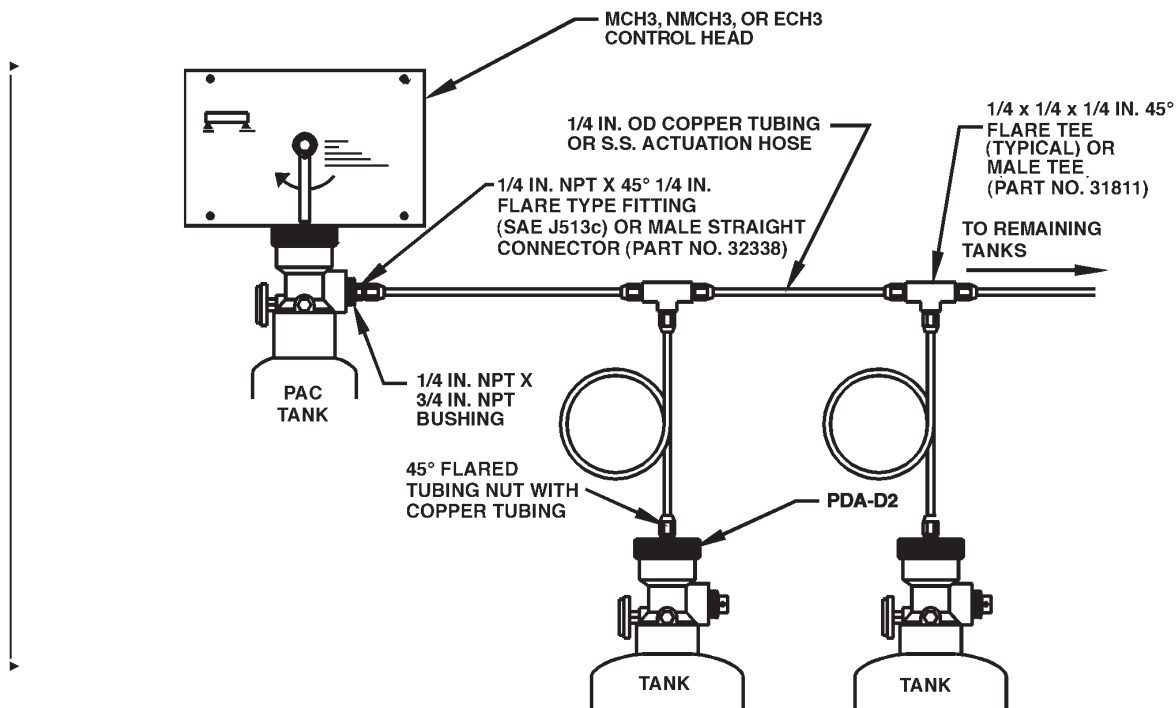

Figure 4-5. Multiple Cylinder Actuation Using Model PAC-10 or PAC-200

002875PC

NOTE

- ▶ Pneumatic tubing used for remote cylinder actuation shall have an outside diameter of 1/4 in. with a minimum wall thickness of 1/32 in. This is commonly known as refrigeration-type copper tubing. All tubing fittings shall be of the 1/4 in., 45° flare type conforming to SAE J513c. **Compression type fittings are not acceptable.**

The Model PAC-10 pneumatic cylinder can actuate a maximum of ten (10) agent cylinders with a maximum of 100 ft (30.5 m) of pneumatic tubing.

The Model PAC-200 pneumatic cylinder can actuate a maximum of twenty (20) agent cylinders with a maximum of 200 ft (61 m) of pneumatic tubing.

▶ **C. Multiple Cylinder Actuation Using Two Control Heads.**

If the system design requires the use of two control heads for multiple cylinder actuation, a maximum of 25 ft (7.6 m) of tubing or stainless steel actuation hose is allowed between the two control heads and the PAC-10 cylinder. See **Figure 4-5a**. If a PAC-10 cylinder is not utilized, there is a maximum of 25 ft (7.6 m) of tubing or stainless steel actuation hose for the two control heads and up to 4 cylinders or a maximum of 18 ft (5.4 m) of tubing or stainless steel actuation hose for the two control heads and 5 cylinders.

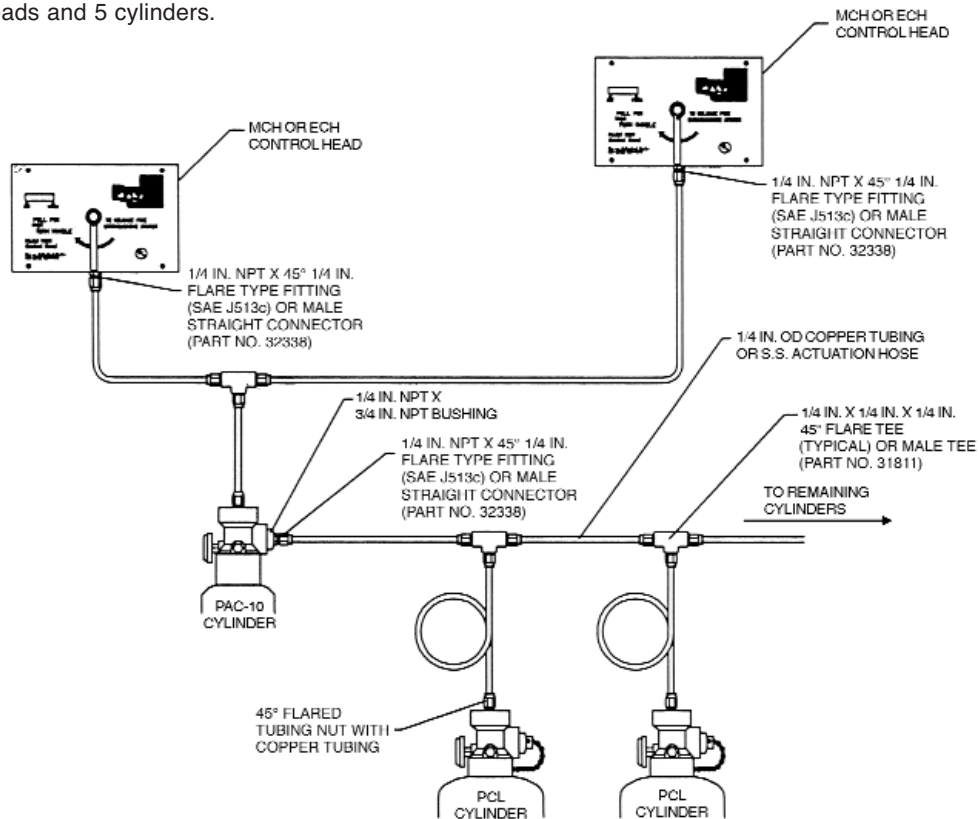

Figure 4-5a. Multiple Cylinder Actuation Using Two Control Heads.

006858

FUSIBLE LINK DETECTOR INSTALLATION

Fusible links are always used in conjunction with the Model MCH3 Mechanical Control Head. After mounting the cylinder and control head, the fusible link line can be installed. The first step to installing the fusible link line is to install the detector bracket(s). These brackets must be installed in the plenum area, hazard area, and in each duct. See **Chapter III** for detector placement guidelines.

Note: Only ML-style Fusible Links can be used.

- ▶ Connect the fusible link brackets together using 1/2 in. conduit and the conduit connectors supplied in the detector kit (Model FLK-1/1A). A PYRO-CHEM corner pulley must be used whenever a change in conduit direction is necessary. The conduit is connected to the control head through a knockout in the upper left-side corner.

In general, fusible links centered in the detector brackets

- ▶ are connected in series using 1/16 in. diameter stainless steel cable. The spring plate in the control head maintains tension on this series of fusible links. If the tension is released for any reason (i.e., a fusible link separates), the control head will operate and actuate the system. Maximum limitations for the fusible link detection line are as follows:

Fusible links can be installed with or without fusible link hangers (see **Chapter II** for description).

Fusible Link Line Limitations When Used With Model MCH3 and NMCH3 Control Heads and Part No. 415670 and 423250 Pulley Elbows

Maximum # of Detectors:	20
Maximum length of cable:	150 ft (45.7 m)
Maximum # of pulleys:	40

1. Fusible Link Installation Without Hangers.

Begin installing links at the terminal bracket. The link is connected to the far side of the terminal bracket using an “S” hook. The “S” hook must be crimped closed after the link is installed. A tight loop is then made in the cable and secured by the crimp provided. This loop is connected to the other side of the terminal link (see **Figure 4-6**) and the cable fed through the conduit to the next bracket. The cable proceeding from the terminal link will be used to connect the series links (see **Figure 4-7**). Series links must be centered in their detector brackets.

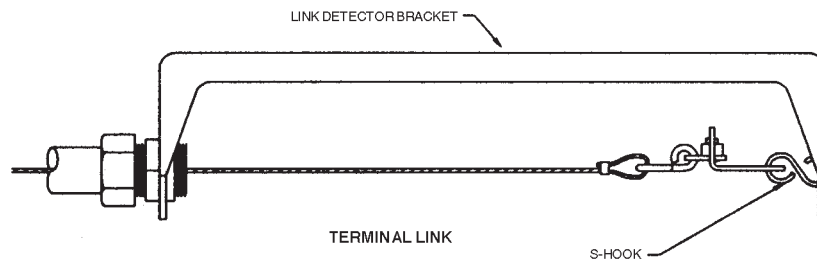

Figure 4-6. Terminal Link Installation.

002849aPC

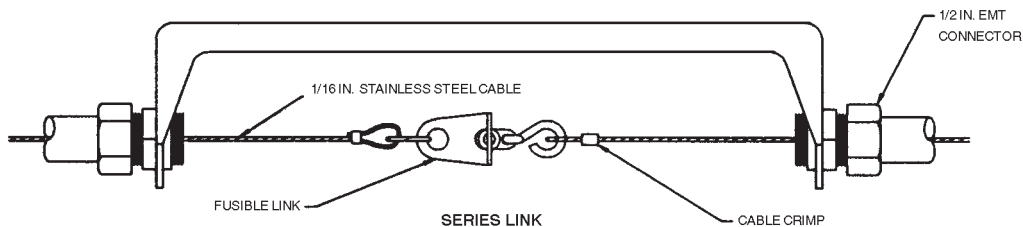

Figure 4-7. Series Link Installation.

002849bPC

After the last link in the series is connected, the cable should be fed through the conduit back to the control head. Thread the cable through the hole in the fusible link ratchet wheel. The line must then be crimped, and the crimp positioned inside the center of the ratchet wheel.

NOTE

Crimps must always be used in conjunction with two (2) cable lengths. Loops are the accepted method of connecting the cable to mechanical components. The crimp must never be used on a single cable.
 Exception: Single cable crimp allowed in detection and gas valve ratchet wheel using stop sleeve, Part No. 26317 (packages of 10: Part No. 24919).

The fusible link line can now be put into a set position by applying tension to the fusible link line. This is accomplished by using a 1/2 in. hex wrench on the fusible link line ratchet wheel. The ratchet wheel will be ratcheted in a clockwise direction until the spring plate makes contact with the top of the control head box. The fusible link line is now in a set position. See Figure 4-8.

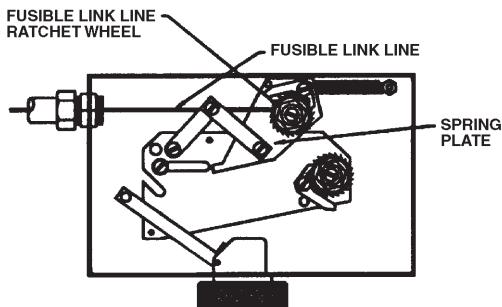

Figure 4-8. Fusible Link Line Termination.

002876PC

2. Fusible Link Installation Using Model FLH-1 Fusible Link Hangers.

Beginning at the control head, feed the stainless steel cable through the conduit and brackets to the terminal bracket in one continuous length. Allow approximately 2.5 in. (6.4 cm) of slack at each bracket for the installation of the Fusible Link Hangers. At the terminal link, a tight loop is made in the cable and secured by the crimp provided. The cable is attached to the far side of the terminal bracket using an "S" hook. The "S" hook must be crimped closed after the cable is installed. See Figure 4-9.

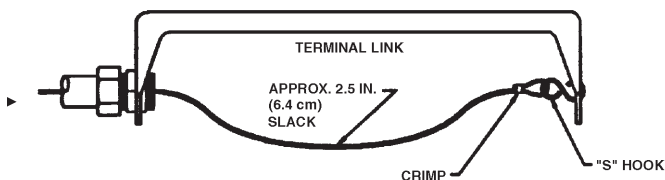

Figure 4-9. Terminal Bracket Connection.

002877PC

Begin installing the Fusible Link Hangers at the terminal bracket and work toward the control head. Loop the cable through the oval opening in the hanger and hook the fusible link on the loop. See Figure 4-10.

Note: Only ML-style Fusible Links can be used

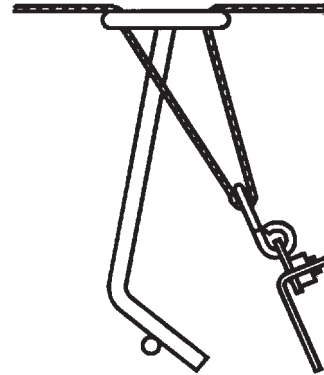

Figure 4-10. Fusible Link Connection.

002878PC

Hook the bottom of the link onto the bottom leg of the hanger. See Figure 4-11.

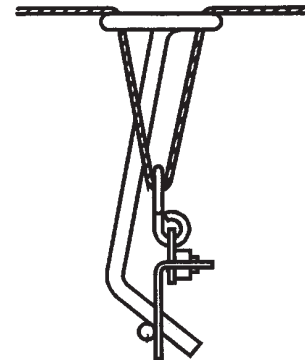

Figure 4-11. Fusible Link/Hanger Connection.

002879PC

Center the hanger/link in the fusible link bracket by sliding it along the link line. This is easily accomplished before any tension is applied to the link line. Repeat this procedure for all fusible links.

After the last hanger/link in the series is connected, the cable should be fed through the hole in the fusible link ratchet wheel. The line must then be crimped, and the crimp positioned inside the center of the ratchet wheel.

NOTE

Crimps must always be used in conjunction with two (2) cable lengths. Loops are the accepted method of connecting the cable to mechanical components. The crimp must never be used on a single cable.
 Exception: Single cable crimp allowed in detection and gas valve ratchet wheel using stop sleeve, Part No. 26317 (packages of 10: Part No. 24919).

The fusible link line can now be put into a set position by applying tension to the fusible link line. This is accomplished by using a 1/2 in. hex wrench on the fusible link line ratchet wheel. The ratchet wheel will be ratcheted in a clockwise direction until the spring plate makes contact with the top of the control head box. The fusible link line is now in a set position. See **Figure 4-8**. Check to ensure that the fusible link hanger(s) remain centered in the bracket after the fusible link line is set. See **Figure 4-12**.

THERMAL DETECTOR INSTALLATION

Thermal detectors are always used in conjunction with the Model ECH3 Electrical Control Head. After mounting the cylinder and control head, the thermal detector(s) can be installed. See **Chapter III** for detector placement guidelines. Follow the instructions included with the detector for proper detector mounting procedures.

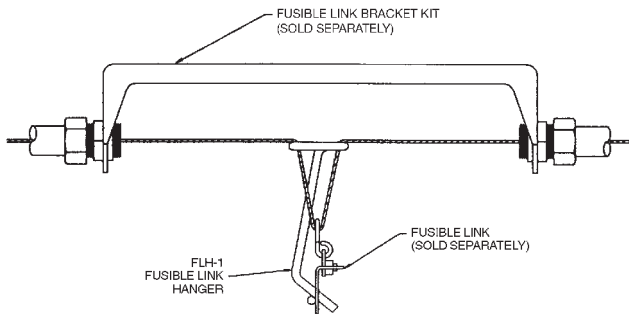

Figure 4-12. Fusible Link/Hanger In Set Position
 002850PC

SETTING THE CONTROL HEAD

1. Model MCH3/NMCH3 Mechanical Control Head.

Once the fusible link line is set, the control head can be placed in the set position. To set the control head, the slide plate is moved from right to left, ensuring the bolt extending from the cam arm is in the slot provided in the slide plate. Continue moving the slide plate to the left until the latching arm is in the locked position. Insert the pull pin into the hole in the slide plate above the latching arm. This will lock the control head in the set position, eliminating accidental actuation during the rest of the installation procedure. See **Figure 4-13**.

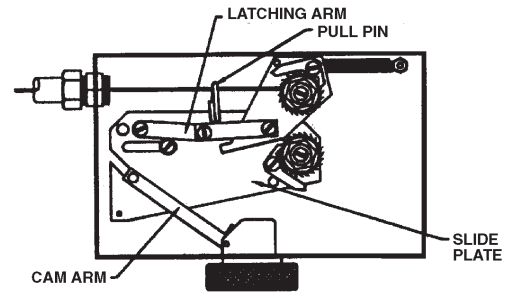

Figure 4-13. Control Head In Set Position.
 002880PC

2. Model ECH3 Electrical Control Head.

Once the thermal detectors have been installed, the control head can be placed in the set position. To set the control head, the slide plate is moved from right to left, ensuring the bolt extending from the cam arm is in the slot provided in the slide plate. Continue moving the slide plate to the left until the latching arm is in the locked position. Insert the pull pin into the hole in the slide plate above the latching arm. This will lock the control head in the set position, eliminating accidental actuation during the rest of the installation procedure.

Once the Model ECH Electrical Control Head is in the set position, it can be connected to the detection/actuation circuit.

NOTE

No electrical connections shall be made inside the control head. All electrical wiring shall exit the control head through the knock-out on the side of the box. All electrical connections must be made in an approved electrical box.

Connect one of the black wires on the solenoid in the control head to the red wire of the Model MS-SPDT Micro Switch. The brown wire from the micro switch is then connected to one side of the first thermal detector in series. Connect the other side of the first thermal detector in series and the remaining black wire on the solenoid in the control head to the appropriate power source after installing the Model SM-24/120 Solenoid Monitor.

CAUTION

The solenoid must never be wired "hot" (not through the micro-switch). If wired this way, the non-field replaceable solenoid will be damaged and the complete control head will require replacement.

NOTE

A Model SM-24/120 Solenoid Monitor must always be used with an Electrical Control Head to supervise the actuation/detection circuit.

The Model ECH3-24 Electrical Control Head requires a UL Listed 24VDC power supply with a minimum 2A rating. The Model ECH3-120 Electrical Control Head requires a 1A, 120VAC power supply.

SOLENOID MONITOR INSTALLATION

1. Solenoid Monitor Installation In Detection Circuit.

After installing the thermal detectors and the control head, the Model SM-120/24 Solenoid Monitor can be installed. The Solenoid Monitor is connected to the wires leading from the last thermal detector. It should be mounted in a location where it can be readily observed.

The Solenoid Monitor is an end-of-line device that supervises the actuation/detection circuit. It is comprised of a push-type switch with a built-in indicator light, a plug-type relay, a relay socket, and a cover plate. The light, when illuminated, indicates that the detection/actuation circuit is in the normal condition. The Solenoid Monitor also provides two sets of dry contacts. The Solenoid Monitor's cover plate is used to mount the Solenoid Monitor in a standard 6 in. x 4 in. x 3 in. deep electrical box (See **Figure 4-14**).

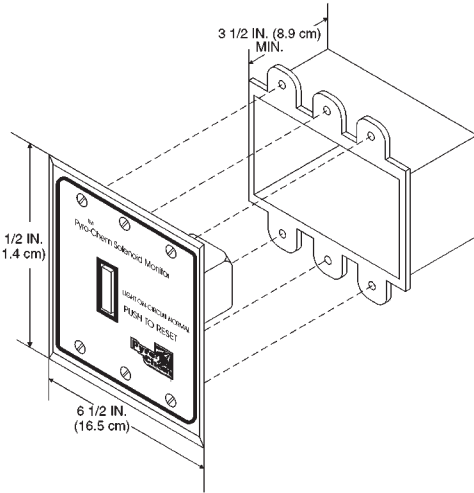

Figure 4-14. Solenoid Monitor Installation.

002881PC

- All wire for circuits using the Model SM-24 shall be 18 gauge minimum, or as required by local code.
- All wire for circuits using the Model SM-120 shall be 14 gauge minimum, or as required by local code. The basic wiring diagram for both the Model SM-24 and Model SM-120 is shown in **Figure 4-14.1**.

After the Solenoid Monitor has been installed, the detection/actuation circuit can be connected to the appropriate power source and energized. To energize the detector/actuation circuit, depress the switch on the Solenoid Monitor. The light will illuminate to indicate that the circuit is properly installed. If the light fails to illuminate, the wiring must be checked.

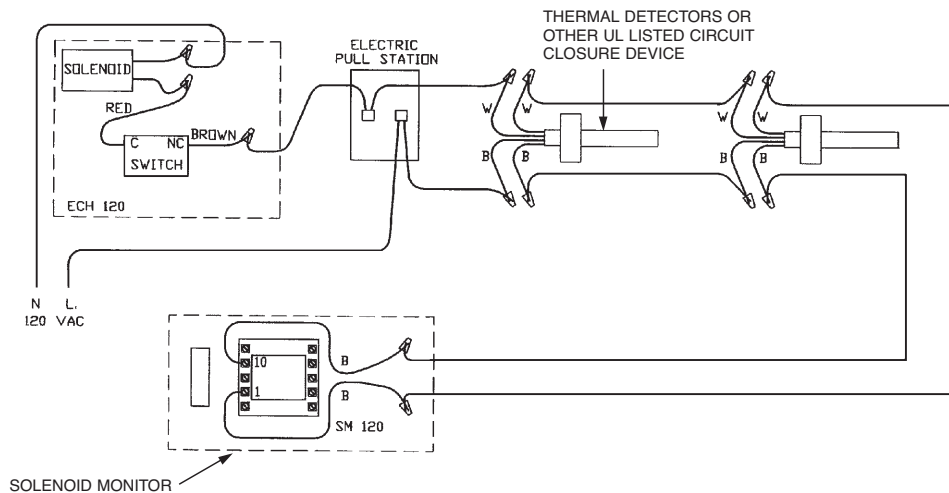

Figure 4-14.1. Wiring Diagram, Solenoid.

002882PC

2. Solenoid Monitor When Used As A Reset Relay

The Model SM-24/120 can be used as a reset relay when required. A reset relay is required whenever an electrical gas shut-off valve is used in conjunction with the Pyro-Chem Booth Industrial Fire Suppression System. For typical wiring connections, see **Figure 4-15**.

REMOTE PULL STATION INSTALLATION

1. Model RPS-M.

The Model RPS-M Remote Mechanical Pull Station is used for remote mechanical actuation of the Model MCH3/ECH3/NMCH3 Control Head. It is to be located near an exit in the path of egress from the hazard area no more than 4 ft (1.2 m) above the floor.

NOTE

A model RPS-M remote mechanical pull station must be used for manual actuation of a Model NMCH3 releasing device.

The Pull Station can be surface mounted or recessed. It is connected to the control head using 1/16 in. diameter stainless steel cable. The cable enters the pull station box from the bottom, top, either side, or back. The cable enters the control head through the top-center knockout. The cable must be enclosed in 1/2 in. conduit with a PYRO-CHEM corner pulley at each change in conduit direction. Maximum limitations for the Model RPS-M Remote Mechanical Pull Station are as follows:

Model RPS-M Cable Run Limitations When Used With Model MCH3, ECH3, and NMCH3 Control Heads and Part No. 415670 and 423250 Pulley Elbows

- ▶ Maximum length of cable: 150 ft (45.7 m)
- ▶ Maximum # of pulleys: 40

After mounting the pull station box and conduit, feed the stainless steel cable from the control head, through the conduit, and into the pull station box. Insert the bushing into the pull station's cover plate and secure it with the locknut provided. Feed the cable through the bushing and into the pull handle ensuring that the cable fully crosses the set screw hole. Fasten the cable to the pull handle with the set screw (see **Figure 4-16**).

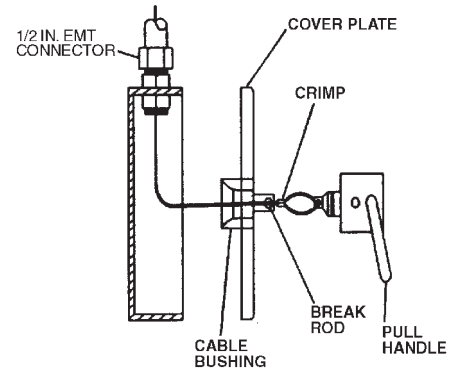

Figure 4-16. Model RPS-M Remote Pull Station Installation.

002884PC

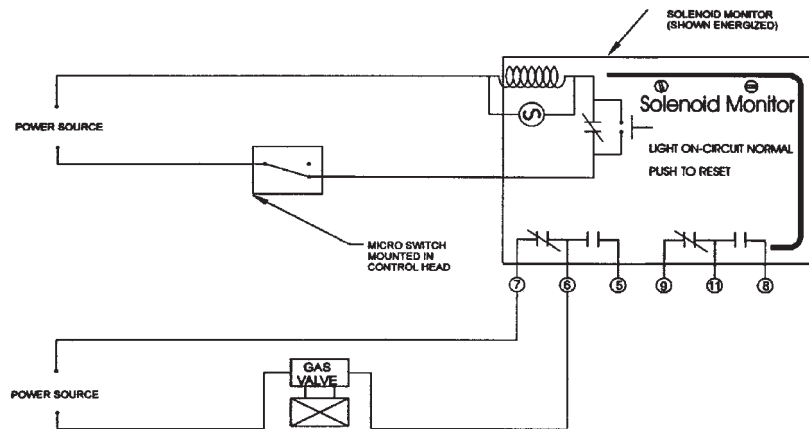

Figure 4-15. Solenoid Monitor Wiring With Electrical Gas Shut-off Valve.

002883PC

NOTE

Crimps must always be used in conjunction with two (2) cable lengths. Loops are the accepted method of connecting the cable to mechanical components. **The crimp must never be used on a single cable.**
 Exception: Single cable crimp allowed in detection and gas valve ratchet wheel using stop sleeve, Part No. 26317 (packages of 10: Part No. 24919).

Cut and thread the cable through the hole in the latching arm of the control head and pull the cable tight. Crimp the cable 6 in. (15.2 cm) below the latching arm.

Pull the pull handle until the crimp touches the latching arm. Coil the excess cable in the pull box and attach the cover plate with the four screws provided. Insert the pull handle into the cover plate and insert the pull pin through the bushing and the pull handle. Secure the pull pin with the nylon tie provided. See Figure 4-17.

2. Model RPS-E2.

The Model RPS-E2 remote electrical pull station is used for remote actuation of the Model ECH3 Control Head. It is to be located near an exit in the path of egress from the hazard area no more than 4 ft (1.2 m) above the floor. The Model RPS-E2 is installed in the detection/actuation circuit and wired in accordance with the instructions included. See Figure 4-14.1 for typical circuit wiring.

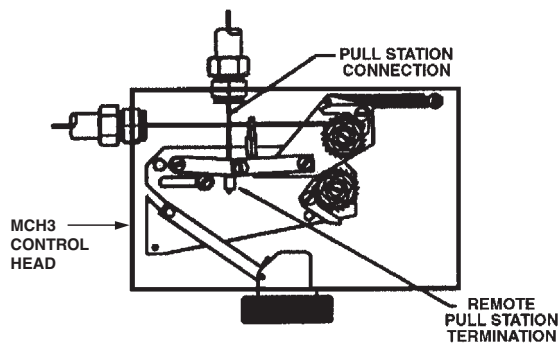

GAS SHUT-OFF VALVE INSTALLATION

1. Mechanical Gas Shut-Off Valve Installation.

The Model MCH3/NMCH3 Control Head is used to operate the mechanical gas shut-off valve. This valve is located in the fuel gas supply line. The valve body has an arrow which indicates direction of gas flow through the valve. The gas shut-off valve is spring loaded and requires five pounds of force to hold it open. This force is supplied by a 1/16 in. diameter stainless steel cable that is connected to the control head. After the valve is installed in the gas line, 1/2 in. conduit must be run from the top center knockout of the gas valve box to the lower right-hand knockout in the control head. A PYRO-CHEM corner pulley is used wherever a change in conduit direction is required.

Gas Valve Cable Run Limitations When Used With Model NMCH3 or MCH3 Control Heads and Part No. 415670 and 423250 Pulley Elbows	
Maximum length of cable:	100 ft (30.5 m)
Maximum # of pulleys:	30

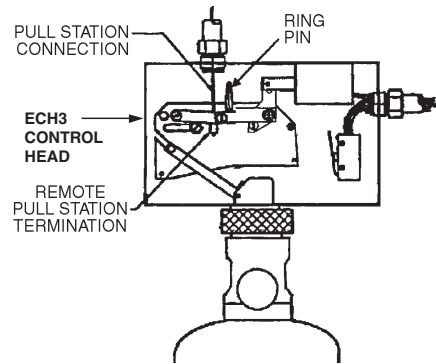

Figure 4-17. Model RPS-M Remote Pull Station Termination.

002885PC/003647PC

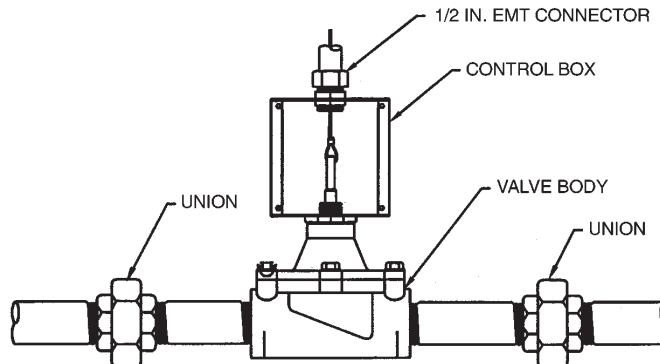

Figure 4-18. Gas Valve Installation.

002886PC

Remove the gas valve cover and thread the stainless steel cable through the conduit back to the control head. Thread the cable through the hole in the gas valve ratchet wheel. The line must then be crimped, and the crimp positioned inside the center of the ratchet wheel.

At the gas valve, loop the cable through the valve stem and secure it with the crimp provided (see **Figure 4-18**).

- **Note:** See Chapter 2 – Components for maximum dimension to extend valve stem.

The gas valve line can now be put into a set position by applying tension to the gas valve line. This is accomplished by using a 1/2 in. hex wrench on the gas valve ratchet wheel. The ratchet wheel will be ratcheted in a clockwise direction until the gas valve is fully open. Secure the gas valve cover plate to the gas valve box with the four (4) screws provided. The gas valve line is now in a set position. See **Figure 4-19**.

CAUTION

Overtightening the gas valve may cause the system not to actuate.

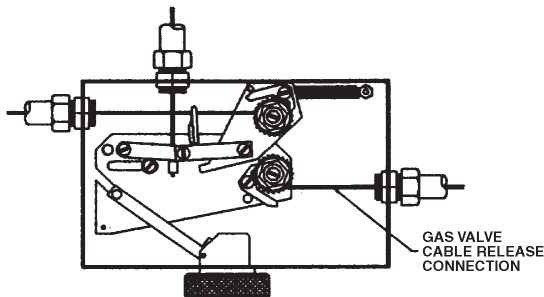

Figure 4-19. Gas Valve Line Termination.
 002887PC

2. Electrical Gas Shut-Off Valve Installation.

The Model MCH3/ECH3/NMCH3 Control Head is used to operate the electrical gas shut-off valve. This valve is located in the fuel gas supply line. The valve body has an arrow which indicates direction of gas flow through the valve. A reset relay must always be used with an electrical gas shut-off valve. For proper wiring of the electrical gas shut-off valve, see **Figure 4-15**.

TEE PULLEY INSTALLATION

The Model TP-1 Tee Pulley is used to connect two (2) mechanical gas valves or two (2) remote mechanical pull stations to a single control head. The cable proceeding from the control head must always enter the branch of the tee pulley. See **Figure 4-20**.

A tee pulley that is used to close two (2) gas valves can only be used to close gas valves with similar stem travel. Gas valves from 3/4 in. up to 1 1/2 in. can be used on the same tee pulley. A 2 in. gas valve can be used only with another 2 in. gas valve. Gas valves from 2 1/2 in. up to 3 in. can be used on the same tee pulley. As an example, using a 3/4 in. gas valve with a 3 in. gas valve will not allow the 3 in. valve to fully open.

CAUTION

The tee pulley must never be used to connect multiple fusible link lines to a single control head.

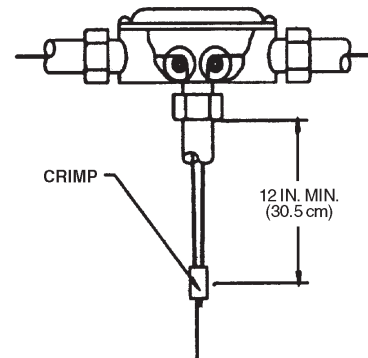

Figure 4-20. Tee Pulley Installation.
 002888PC

MICRO SWITCH INSTALLATION

See NFPA 72, “National Fire Alarm Code,” Initiating Devices section, for the correct method of wiring connection to the fire alarm panel.

The Model MS-SPDT, MS-DPDT, MS-3PDT, or MS-4PDT Micro Switch is available for use where an electrical output is required. These switches can be field installed in the control head. See **Figure 4-21** and **Figure 4-22** and refer to Instruction Sheet, Part No. 551159, included with switch shipping assembly, for detailed mounting instructions.

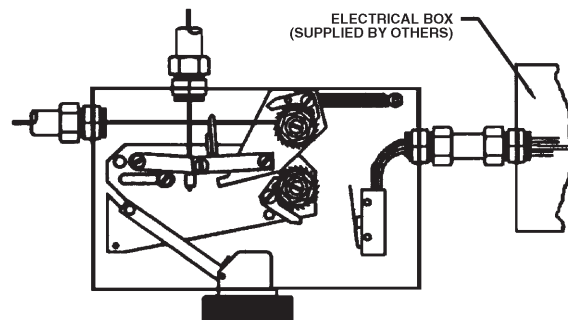

Figure 4-21. Micro Switch Installation in Model MCH3/NMCH3 Control Head.
 002889PC

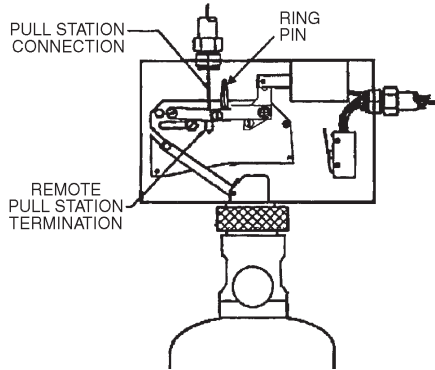

Figure 4-22. Micro Switch Installation in Model ECH3 Control Head.

003647PC

NOTE

The Model ECH3 Control Head is supplied with a Model MS-DPDT Micro Switch. This switch can be used in the actuation/detection circuit and for electrical output.

These switches may be used to provide an electrical signal to the main breaker and/or operate electrical accessories provided the rating of the switch is not exceeded. Wiring connections are shown in **Figure 4-23**. The contact ratings for the switches are as follows:

Contact Ratings For Micro Switches

21 amps, 1 HP, 125, 250, 277 VAC
 or 2 HP, 250, 277 VAC

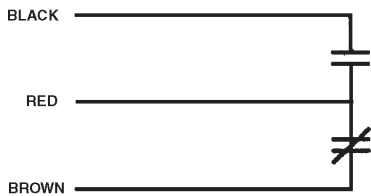
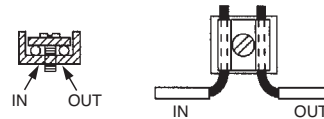
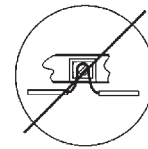
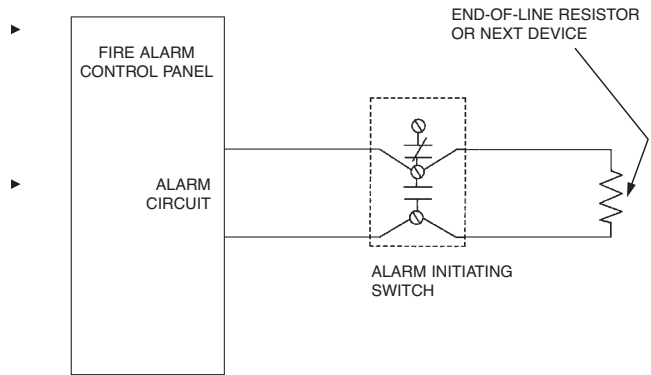

Figure 4-23. Wiring Diagram For Model MS-SPDT Micro Switch.

002903PC

The Alarm Initiating Switch, Part No. 550077, must be used to close a supervised alarm circuit to the building main fire alarm panel when the control head actuates. This will signal the fire alarm panel that there was a system actuation in the hazard area. This switch can be field installed in the control head. Refer to Instruction Sheet, Part No. 550081, included with the switch shipping assembly, for detailed mounting instructions. Wiring connections are shown in **Figure 4-24**. The switch is rated at 50mA, 28VDC.



CORRECT – SEPARATE INCOMING AND OUTGOING CONDUCTORS

Figure 4-24. Wiring Diagram for Alarm Initiating Switch.

004891/004905

PIPE AND NOZZLE INSTALLATION

General Piping Requirements

1. Use Schedule 40 black iron (if used in a relatively non-corrosive atmosphere), galvanized, chrome-plated, or stainless steel pipe conforming to ASTM A120, A53, or A106. Fittings must be a minimum of 150 lb Class. However, the PCI 35, 50, and 70 lb cylinders must have a minimum of two (2) nozzles per cylinder to utilize the 150 lb Class fittings. If the PCI 35, 50, or 70 lb cylinder has one (1) nozzle, then a 300 lb Class fitting must be used. The remaining Monarch cylinders have no limitations for the 150 lb Class fittings. Distribution pipe sizes are 3/4 in. or 1 in. depending on number of nozzles.
2. Pipe unions are acceptable.
3. Use reducing tees for all pipe splits.
4. Reducing bushings are not acceptable.
5. Cast iron pipe and fittings are not acceptable.
6. **Pipe thread sealant or pipe joint compound is not allowed for distribution piping.**
7. Bell Reducer or any non-restrictive fittings are allowed.
8. Before assembling the pipe and fittings, make certain all ends are carefully reamed and blown clear of chips and scale. Inside of pipe and fittings must be free of oil and dirt.

- ▶ 9. If Teflon tape is used on threaded ends, start at the second male thread and wrap the tape clockwise around the threads, away from the pipe opening.
- ▶ 10. All system piping must comply with Section A-5-9.1 of NFPA-17.

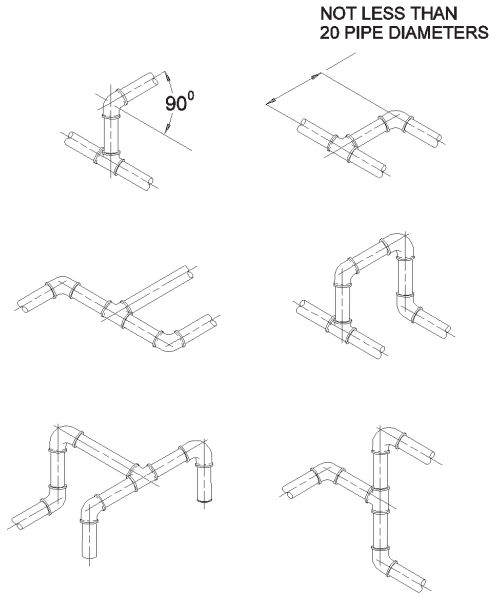

▶ **Figure 4-25. Acceptable Piping Methods.**

002965PC

CAUTION

Do not apply Teflon tape to cover or overlap the pipe opening, as the pipe and nozzles could become blocked and prevent the proper flow of agent.

▶ **TEE POSITIONING**

In order to obtain equal distribution at a tee, the dry chemical must enter the side port of the tee and exit through the two end ports. See **Figure 4-26**.

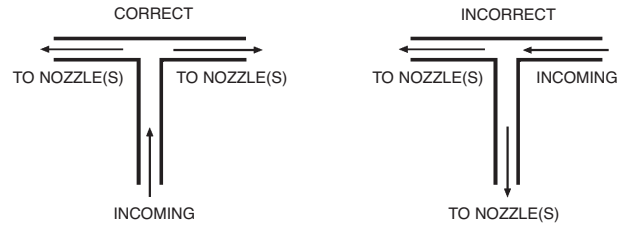

Figure 4-26. Tee Positioning

003126

Hanger/Support Installation

The hanger/supports must be installed in conjunction with the pipe and fittings. The spacing requirements for hangers/supports depend on the pipe size being utilized; refer to the Spacing Guidelines Chart.

PIPE HANGER SPACING GUIDELINES CHART

Distribution Pipe Size	Maximum Spacing Distance Hanger to Hanger	
	ft	m
▶ 1/4	4	(1.2)
▶ 1/2	6	(1.8)
▶ 3/4	8	(2.4)
▶ 1	12	(3.6)

Other factors that influence hanger/support spacing are:

- ▶ Hanger/Support must be placed within 1 ft (0.3 m) of the discharge nozzle.

Hanger/Support must be placed between elbows when distance is greater than 2 ft (0.6 m).

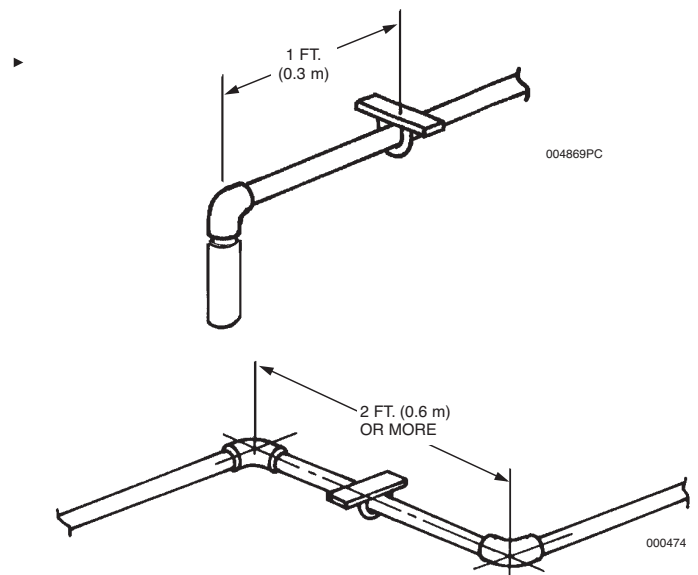

▶ **Figure 4-27. Hanger/Support.**

004869PC

000474

MAIN/RESERVE SYSTEM

When a reserve system is being utilized, two 1 in. swing check valves, Part No. 417788, must be installed in the distribution piping network. They should be positioned as close as possible to the “Y” fitting joining the piping from the main and reserve tanks to one common supply pipe. See **Figure 4-28**. **Note:** Make certain to install swing check valves in the direction of dry chemical flow as shown with an arrow stamped on the valve body.

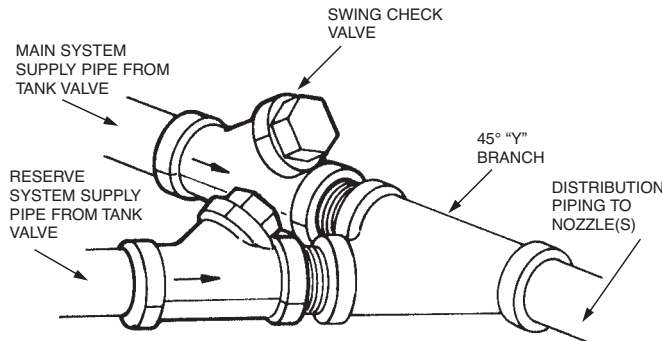

Figure 4-28. Main/Reserve System.

000480

PRESSURE SWITCH INSTALLATION

The Model PS-SPDT-X Pressure Switch is available for use when an electrical output is required. It must be installed in the discharge piping within 12 in. (30.5 cm) of the valve discharge port as shown in **Figure 4-29**. An inline tee is used for the installation. The switch is isolated from the chemical by a 12 in. to 15 in. (30.5 to 38.1 cm) column of air in the form of a vertical pipe nipple. The switch is then mounted at the top of this nipple.

NOTE

Piping for pressure switch must be included in total cylinder to T1 piping limitations. The fitting used to connect the pressure switch to the distribution piping counts as one (1) elbow in that section.

As an alternate, the switch may be connected directly to the copper tubing of a remotely mounted control head or a PAC cylinder. The PS-SPDT-X counts as one cylinder in this section, and the limitations on copper tubing and/or pipe previously stated in this manual apply.

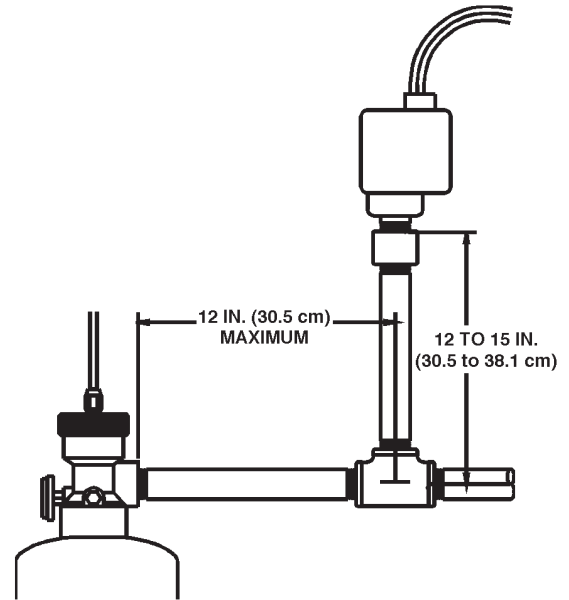

Figure 4-29. Pressure Switch Installation.

003025PC

SYSTEM CHECKOUT AFTER INSTALLATION

1. Model MCH3 Mechanical Control Head.

Before putting the system into service, all components must be checked for proper operation. During this checkout, assure that the carbon dioxide pilot cartridge is not installed in the control head actuator. Remove the pull pin from the hole in the slide plate.

To check satisfactory operation of the control head, cut the terminal link or the “S” hook holding the link. This will relieve all tension on the fusible link line and operate the control head. The slide plate will move fully to the right. The gas valve cable will be released, causing the gas valve to close.

Any auxiliary equipment connected to the dry contacts of the solenoid monitor and/or the Micro Switch in the control head will operate.

If any of these events fail to occur, the problem must be investigated and repaired.

Repair the terminal link and put the fusible link line back into the set position. This is accomplished by using a 1/2 in. hex wrench on the fusible link line ratchet wheel. The ratchet wheel will be ratcheted in a clockwise direction until the spring plate makes contact with the top of the control head box.

Once the fusible link line is set, the control head can be placed in the set position. To set the control head, the slide plate is moved from right to left, ensuring the bolt extending from the cam arm is in the slot provided in the slide plate. Continue moving the slide plate to the left until the latching arm is in the locked position.

Once the control head is set, pull the pull handle on the remote pull station to assure that the control head operates. If the control head operates normally, the control head can be reset as described above. Insert the pull pin into the hole in the slide plate above the latching arm. Replace the pull station handle, pull pin, and nylon tie.

Assure that the gas valve is fully open by ratcheting the gas valve ratchet wheel.

Using a felt-tipped marker, write the date of installation on the carbon dioxide pilot cartridge. Screw the cartridge into the control head actuator until hand-tight. **Never use a wrench to tighten the cartridge into the actuator.**

Remove the pull pin from the hole in the slide plate and install the control head cover. Insert the pull pin through the local manual control handle and into the bushing. Secure the pull pin with the nylon tie provided.

2. Model ECH3-24/120 Electrical Control Head.

Before putting the system into service, all components must be checked for proper operation. During this checkout,

- ▶ assure that the CO₂ pilot cartridge is not installed in the control head actuator. Remove the pull pin from the hole in the slide plate.

CAUTION

Make certain to remove the CO₂ cartridge. Failure to do so during testing will result in system actuation.

Testing Thermal Detectors

1. Remove the electric control head cover.
2. Test each detector individually and recock release mechanism after each test.

- ▶ 3. Using a heat gun positioned approximately 12 in. from the detector, apply heat to the detector for about one minute. Overheating will cause damage to the detector. Applying heat to the detector will cause the control head to operate. When the control head operates, the following will take place: a) The slide plate will move fully to the right; b) The indicator light on the solenoid monitor will go out; and c) Any auxiliary equipment connected to the dry contacts of the solenoid monitor and/or the micro switch in the control head will operate. If any of these events fail to occur, the problem must be investigated and repaired.
4. After all the thermal detectors have cooled, the control head can be placed in the set position. To set the control head, the slide plate must be moved from right to left, ensuring the bolt extending from the cam arm is in the slot provided in the slide plate. Continue moving the slide plate to the left until the latching arm is in the locked position.

Testing Remote Pull Station

1. Once the control head is set, pull the pull handle on the remote pull station to assure that the control head operates. If the control head operates normally, the control head can be reset as described in Step 4 above.
2. Insert the pull pin into the hole in the slide plate above the latching arm.
- ▶ 3. Replace the pull station handle, pull pin, and break rod.

▶ Completing System Checkout

- ▶ 1. Energize the actuation/detection circuit by depressing the push button on the solenoid monitor.
- ▶ 2. Using a felt-tipped marker, write the date of installation on the CO₂ pilot cartridge. Ensure that the actuator has an O-ring installed, and screw the cartridge into the control head actuator until hand tight. **Never use a wrench to tighten the cartridge into the actuator.**
- ▶ 3. Remove the pull pin from the hole in the slide plate and install the control head cover. Insert the pull pin through the local manual control handle and into the bushing. Secure the pull pin with the tie provided.

NOTE

Refer to NFPA-17 for additional inspection requirements.

NOTES:

CHAPTER V SYSTEM MAINTENANCE

GENERAL

This chapter will detail the basic information necessary for proper maintenance of the PYRO-CHEM Industrial Fire Suppression System. However, before attempting any system maintenance, it is necessary to attend a Factory Certification Training Class and become Certified to install and maintain the PYRO-CHEM Industrial Fire Suppression System.

MAINTENANCE AFTER SYSTEM DISCHARGE

1. System Cleanup.

The hazard area cleanup after a system discharge is very basic. The dry chemical agent should be cleaned up by either sweeping or vacuuming. Residual dry chemical should be wiped off effected surfaces with a damp cloth.

2. System Cylinder Recharge.

CAUTION

Protective eye goggles and protective footwear must be worn when performing system maintenance.

1. Remove the cylinder from the control head or pneumatic adaptors and inspect for visual damage. If there is any damage the cylinder must be hydrostatically tested before being refilled. If there is no damage, the cylinder can be recharged.
2. Reset all pneumatic actuators (Models PDA-D2) by depressing the check valve on top and relieving the pressure. Remove the pneumatic actuator or control head from the valve and use any 1/4-20 UN screw or bolt to screw into the top of the piston. Pull up on the piston until the piston is flush with the top of the valve body and remove the screw or bolt from the piston.
3. Remove the valve and siphon tube assembly from the cylinder and unscrew the siphon tube from the valve.
4. Inspect the valve to make sure no mechanical damage has occurred. If there is evidence of any damage to the seals, rebuild the valve using the Dry Valve Rebuilding Kit (PYRO-CHEM Part Number 550037).
5. Screw the siphon tube back into the valve.

6. Refill the cylinder with agent. Use the table below for easy reference.

<u>Cylinder</u>	<u>Recharge</u>
PCI-15ABC	12.5 lb ABC (Part No. 550696)
PCI-17ABC	17 lb ABC (Part No. 550696)
PCI-25sBC	25 lb BC (Part No. 550695)
PCI-25sABC	25 lb ABC (Part No. 550696)
PCI-35ABC	35 lb ABC (Part No. 550696)
PCI-50sBC	50 lb BC (Part No. 550695)
PCI-50sABC	50 lb ABC (Part No. 550696)
PCI-70ABC	70 lb ABC (Part No. 550696)

- ▶ The Model RC-50ABC (Part No. 550696) is a 50 lb pail of ABC dry chemical recharge agent available from PYRO-CHEM.
- ▶ The Model RC-50BC (Part No. 550695) is a 50 lb pail of BC dry chemical recharge agent available from PYRO-CHEM.

7. Insert the siphon tube into the cylinder, and screw the valve onto the cylinder. Make sure that the valve is screwed completely into the cylinder.
8. Attach the Recharge Adaptor (PYRO-CHEM Part No. 550130) to the discharge port of the valve. The adaptor O-ring should be completely inside the discharge port. Attach a source of dry nitrogen to the adaptor.

Charge the cylinder with dry nitrogen to 350 psi at 70°F.

NOTE

1. The pressure gauge attached to the cylinder valve should not be used to determine when the charging pressure has been reached. A pressure regulator should be used.
2. Higher pressure may be needed during the initial charging stage to blow the agent out of the siphon tube. Secure the cylinder during this stage, as it may jump as the agent is blown from the siphon tube.

9. Slowly disconnect the nitrogen source from the Recharge Adaptor. The cylinder valve will close when the Recharge Adaptor is depressurized. When the valve is closed and the nitrogen source is disconnected from the Recharge Adaptor, remove the recharge adaptor from the valve discharge port. Immediately screw the recoil preventer into the discharge port.

CAUTION

The recoil preventer must remain in the valve discharge port until the cylinder is attached to the piping network.

10. Reinstall the cylinder to the piping network. Reattach the control head or pneumatic adaptor.

3. Piping and Nozzles.

Piping should be blown out with air or dry nitrogen. Nozzle blow off caps should be replaced.

4. System Reset.

All fusible links should be replaced. The fusible link line can now be put into a set position by applying tension to the fusible link line. This is accomplished by using a 1/2 in. hex wrench on the fusible link line ratchet wheel. The ratchet wheel will be ratcheted in a clockwise direction until the spring plate makes contact with the top of the control head box. The fusible link line is now in a set position.

After setting the fusible link line, the system can be put back into service by following the SYSTEM CHECKOUT AFTER INSTALLATION Section of **Chapter IV**.

REGULAR SYSTEM MAINTENANCE

1. Six (6) Month Maintenance.

1. Check that the hazard has not changed.
2. Check that all nylon ties are in place and the system has not been tampered with.
3. Check the entire system for mechanical damage.
- ▶ 4. Check the solenoid monitor.
- ▶ 5. Disconnect the control head or pneumatic tubing from each agent cylinder. Remove the carbon dioxide pilot cartridge and exercise the control head to ensure it is functioning properly. Make sure the gas shut-off valve and the remote pull station are functioning properly.

NOTE

Before continuing, remove the cover from the control head and insert the pull pin in the hole in the slide plate above the latching arm. This will secure the system, preventing accidental discharge.

6. Inspect fusible link detectors for excessive grease buildup. Clean or replace links if necessary. Visually inspect thermal detectors.

NOTE

Methods and frequency of inspection, testing and maintenance of detectors should be in accordance with NFPA-72.

7. Reinstall the carbon dioxide pilot cartridge and replace the control head cover and nylon tie.

CAUTION

Before screwing the carbon dioxide pilot cartridge into the actuator, ensure that the actuator has an O-ring installed.

8. Inspect the cylinder pressure. Tap the gauge lightly to ensure the needle is moving freely. If the gauge shows a loss in pressure indicated by the needle being below the green band, the tank should be removed and recharged per the SYSTEM CYLINDER RECHARGE section of Chapter V (System Maintenance) in this manual.

2. Annual Maintenance.

1. Inspect as per six (6) month maintenance instructions.
2. Disconnect and remove the discharge piping from the system. Using air or nitrogen, blow out the discharge piping. Replace all nozzle caps.
- ▶ 3. Fixed temperature sensing elements of the fusible alloy type shall be replaced at least annually or more frequently, if necessary, to assure proper operation of the system.
- ▶ 4. Test thermal detectors and remote pull station per SYSTEM CHECKOUT AFTER INSTALLATION section located in Chapter IV (System Installation) of this manual. Per NFPA 72, two (2) or more detectors per circuit should be tested. Note individual detector location and date of testing. Within 5 years, all detectors in system must be tested.
5. Replace the carbon dioxide pilot cartridge, recording the date of installation on the cartridge with a felt-tipped marker.

CAUTION

Before screwing the carbon dioxide pilot cartridge into the actuator, ensure that the actuator has an O-ring installed.

3. Six (6) Year Maintenance.

1. Inspect as per annual maintenance instructions.
2. Examine the dry chemical. If there is evidence of caking, the dry chemical shall be discarded.

4. Hydrostatic Testing.

The dry chemical agent cylinder(s) and pneumatic cylinder(s) shall be hydrostatically tested at least every twelve (12) years as per NFPA-17.

NOTE

Refer to NFPA-17 for additional maintenance requirements.